



## SUPPLEMENTARY DOCUMENT 1

# STAGE 1 SUPPLEMENTARY DESCRIPTION 3.1kHz AUDIO BEARER SERVICE CATEGORY

ACIF G500:1998 SIGNALLING SYSTEM NO.7  
INTERCONNECT ISUP (VERSION 1.0)

# 3.1 kHz AUDIO BEARER SERVICE CATEGORY

## TABLE OF CONTENTS

<b>0 GENERAL</b>	<b>1</b>
0.1 Participants	1
<b>1 INTRODUCTION</b>	<b>2</b>
<b>2 REFERENCE</b>	<b>2</b>
<b>3 REQUIREMENTS</b>	<b>2</b>
3.1 General Description	2
3.2 Number Related Information	2
3.3 Service Access	2
3.4 Service Charging Information	2

**0 GENERAL**

This document is part of the suite of documents prepared for by the Network Interworking Industry Forum (NIIF) for the purpose of defining the interconnect services and signalling protocol to be available from interconnecting domestic Australian networks.

This document is now being maintained by the ACIF who has assumed responsibility for the self-regulation of the Australian telecommunication industry. Future versions are envisaged to be published as ACIF standards.

This suite of documents is based on specific ITU-T recommendations, which remain copyright to the ITU-T. Each document indicates a base ITU-T recommendation(s) which have been used.

**0.1 Participants**

The NIIF group that developed this document consisted of the following companies and representatives :

	<b>Representative</b>	<b>Company</b>
<i>Chairperson</i>	Les Graf	Ericsson Australia Pty Ltd
<b>Full Time Members</b>		
	Pietro Fu	AAP Telecommunications Pty Ltd
	Guy Ignatius	Vodafone Pty Ltd
	Adrian Pizzica	Telstra
	Roger Nicoll/ Jeremy Ginger	Optus Communications Pty Ltd
	Thian Tan	Ericsson Australia Pty Ltd
<i>Document Editor</i>	Paul Vella	Telstra
<b>Part Time Members</b>		
	Mark Altamore	Alcatel Australia Pty Ltd
	Paul Jancek	BT Australasia Pty Ltd
	Stan Podbreznik	Nortel Australia Pty Ltd

# 3.1 kHz AUDIO BEARER SERVICE CATEGORY

## 1 INTRODUCTION

This document provides supplementary information for the implementation of the 3.1 kHz bearer service category between interconnecting Australian domestic networks.

This document should be read in conjunction with CCITT Recommendation I.231 Section 3 (1988).

## 2 REFERENCE

CCITT Recommendation I.231 (1988).

*Note : All underlined text in this document is an excerpt from the above reference.*

## 3 REQUIREMENTS

### 3.1 General Description

The 3.1 kHz bearer service category corresponds to the service currently offered in the PSTN, ISDN and Mobile networks. It provides for the transfer of speech and of 3.1 kHz bandwidth audio information such as voice band data via modems and facsimile group 1, 2 and 3 information (Note): The digital signal at the S/T reference point shall conform to Recommendation G.711 (A-law or ~~μ-law~~).

All domestic Australian networks must use A-law encoding for this service.

This bearer service category may be supported using analogue transmission.

### 3.2 Number Related Information

The 3.1 kHz bearer service category does not require the use of any new numbers or codes.

No additional network interconnection information specific to this bearer service category, is required in the call set-up process.

### 3.3 Service Access

This service must be implicitly supported in all domestic Australian networks supporting a telephony service.

Selection of this bearer service category may be explicitly supported by an Integrated Service Digital Networks (ISDN) or a GSM Mobile networks. In these cases the relevant ITU-T ISDN DSS1 or GSM standard for selecting this bearer service category must be applied.

### 3.4 Service Charging Information

Specific intercarrier charging arrangements may be applied based on detection of this bearer service category.



## SUPPLEMENTARY DOCUMENT 2

**STAGE 1 SUPPLEMENTARY DESCRIPTION  
64 kbit/s UNRESTRICTED  
BEARER SERVICE CATEGORY**

## TABLE OF CONTENTS

<b>GENERAL</b>	<b>1</b>
0.1. Participants	1
<b>1. INTRODUCTION</b>	<b>2</b>
<b>2. REFERENCES</b>	<b>2</b>
<b>3. REQUIREMENTS</b>	<b>2</b>
3.1. General Description	2
3.2. Number Related Information	2
3.3. Service Access	2
3.4. Service Charging Information	2

## 0 GENERAL

This document is part of the suite of documents prepared for by the Network Interworking Industry Forum (NIIF) for the purpose of defining the interconnect services and signalling protocol to be available from interconnecting domestic Australian networks.

This document is now being maintained by the ACIF who has assumed responsibility for the self-regulation of the Australian telecommunication industry. Future versions are envisaged to be published as ACIF standards.

This suite of documents is based on specific ITU-T recommendations, which remain copyright to the ITU-T. Each document indicates a base ITU-T recommendation(s) which have been used.

### 0.1. Participants

The NIIF group that developed this document consisted of the following companies and representatives :

	<b>Representative</b>	<b>Company</b>
<i>Chairperson</i>	Les Graf	Ericsson Australia Pty Ltd
<b>Full Time Members</b>		
	Pietro Fu	AAP Telecommunications Pty Ltd
	Philip Fong / Guy Ignatius	Vodafone Pty Ltd
	Adrian Pizzica	Telstra
<i>Document Editor</i>	Roger Nicoll / Jeremy Ginger	Optus Communications Pty Ltd
	Thian Tan	Ericsson Australia Pty Ltd
	Paul Vella	Telstra
<b>Part Time Members</b>		
	Mark Altamore	Alcatel Australia Pty Ltd
	Paul Jancek	BT Australasia Pty Ltd
	Stan Podbreznik	Nortel Australia Pty Ltd

## 1. INTRODUCTION

This document provides supplementary information for the implementation of the 64 kbit/s bearer service category between interconnecting Australian domestic networks.

This document should be read in conjunction with ITU-T Recommendation I.231 Section 1.2.1.

## 2. REFERENCES

CCITT Recommendation I.231, Section 1.2.1, 1988.

*Note: All underlined text in this document is an excerpt from the above reference.*

## 3. REQUIREMENTS

### 3.1. General Description

This circuit-mode bearer service category allows:

- two users (e.g. terminals, PABXs) in a point-to-point configuration to communicate via the ISDN using 64 kbit/s digital signals over the B-channel, in both directions continuously and simultaneously for the duration of the call;

~~- three or more users in a multipoint configuration (refer to I.254 for the supplementary service description on Three-Party Services and Conference Calling);~~

### 3.2. Number Related Information

The 64 kbit/s bearer service category does not require the use of any new numbers or codes.

No additional network interconnection information specific to this bearer service category, is required in the call set-up process.

### 3.3. Service Access

Selection of this bearer service category may be explicitly supported by an Integrated Service Digital Network (ISDN) or a GSM Mobile network. In these cases the relevant ITU-T ISDN DSS1 or GSM standard for selecting this bearer service category must be applied.

### 3.4. Service Charging Information

Specific intercarrier charging arrangements may be applied based on detection of this bearer service category.





SUPPLEMENTARY DOCUMENT 3

**STAGE 1 SUPPLEMENTARY DESCRIPTION  
CALL DIVERSION SERVICES**

# CALL DIVERSION SERVICES

## TABLE OF CONTENTS

<b>0 GENERAL</b>	<b>1</b>
0.1 Participants	1
<b>1 INTRODUCTION</b>	<b>2</b>
<b>2 REFERENCE</b>	<b>2</b>
<b>3 REQUIREMENTS</b>	<b>2</b>
3.1 General Description	2
3.2 Number Related Information	4
3.3 Service Access	4
3.4 Service Charging Information	5

**0 GENERAL**

This document is part of the suite of documents prepared for by the Network Interworking Industry Forum (NIIF) for the purpose of defining the interconnect services and signalling protocol to be available from interconnecting domestic Australian networks.

This document is now being maintained by the ACIF who has assumed responsibility for the self-regulation of the Australian telecommunication industry. Future versions are envisaged to be published as ACIF standards.

This suite of documents is based on specific ITU-T recommendations, which remain copyright to the ITU-T. Each document indicates a base ITU-T recommendation(s) which have been used.

**0.1 Participants**

The NIIF group that developed this document consisted of the following companies and representatives :

	<b>Representative</b>	<b>Company</b>
<i>Chairperson</i>	Les Graf	Ericsson Australia Pty Ltd
<b>Full Time Members</b>		
	Pietro Fu	AAP Telecommunications Pty Ltd
	Guy Ignatius	Vodafone Pty Ltd
	Adrian Pizzica	Telstra
	Roger Nicoll/ Jeremy Ginger	Optus Communications Pty Ltd
	Thian Tan	Ericsson Australia Pty Ltd
<i>Document Editor</i>	Paul Vella	Telstra
<b>Part Time Members</b>		
	Mark Altamore	Alcatel Australia Pty Ltd
	Paul Jancek	BT Australasia Pty Ltd
	Stan Podbreznik	Nortel Australia Pty Ltd

## 1 INTRODUCTION

This document provides supplementary information for the implementation of the Call Diversion Services to be supported between interconnecting Australian domestic networks.

Call Diversion services have been supported in the Australian market place for some time and the inherent interworking relationship of these established services must be fully considered in any new or alternate network implementations.

This document should be read in conjunction with ITU-T Recommendation I.252 Sections 2,3 and 4.

## 2 REFERENCE

ITU-T Recommendation I.252 (1993).

*Note : All underlined text in this document is an excerpt from the above reference.*

## 3 REQUIREMENTS

### 3.1 General Description

**The Call Diversion services implementation supported is based on the ITU-T 1993 recommendations. It should be noted that the ITU-T 1993 Recommendations are NOT fully compatible with the previous CCITT 1988 Recommendations for these services.**

**The implementation of this description and its associated components will therefore not support interworking between ITU-T 1993 and CCITT 1988 systems. Should such interworking be required then resolution must be sort bilaterally between interworking networks.**

The following Call Diversion services are considered in this description :

Call Forwarding Busy (CFB)

Call Forwarding No Reply (CFNR)

Call Forwarding Unconditional (CFU),and

Call Forwarding Not Reachable (CFNRC)

Each of these Call Diversion services allow for the forwarding by an access network of incoming calls to a predetermined number under specific conditions.

Call Forwarding Busy (CFB) permits the forwarding user to have their access network send to another number all incoming calls for the forwarding user's number (or just those associated with a specific basic service) which meet busy at the forwarding user's number. The forwarding user's originating service is unaffected.

The busy state may be either network determined or user determined.

Call Forwarding No Reply (CFNR) permits the forwarding user to have their access network send to another number all incoming calls for the forwarding user's number which meet no reply, or just those associated with a specific basic service which meet no reply. The forwarding user's originating service is unaffected.

Call Forwarding Unconditional (CFU) permits the forwarding user to have their access network send to another number all incoming calls for the forwarding user's number (or just those associated with a specific basic service). If this service is activated, calls are forwarded no matter what the condition of the termination. Other Call Forwarding services provide for call forwarding based on condition e.g. Call Forwarding Busy (CFB) and Call Forwarding No Reply (CFNR). The forwarding user's originating service is unaffected.

Call Forwarding Not Reachable (CFNRc) permits the forwarding user to have their mobile access network send to another number all incoming calls for the forwarding user's number (or just those associated with a specific basic service) where the mobile access network determines that the forwarding user is Not Reachable.

The Not Reachable state is network determined and based on the following conditions :

- 1.No acknowledgement to mobile network paging.
- 2.Congestion on Radio resources.
- 3.The mobile user has no radio contact with the mobile access network.
- 4.The mobile user is deregistered from the visitor location register.

The Call Diversion services (CFU, CFB,CFNR and CFNRc) exhibit some operational commonality, wherby :

- The forwarded-to number can be subject to restriction. That is,certain network destinations may not be allowed as a forwarded-to number (eg.directory assistance and emergency operators).
- A specific Call Forwarding Inhibit Calling Party Category (as identified within the signalling system) has been defined for specific interworking call cases.
- On receipt of the specific Call Forwarding Inhibit Calling Party Category the access network of the called party must not allow further call forwarding. However, the call can be offered to the called number directly, in accordance with normal call procedures.

***Note : This requirement is necessary to allow the continued support of the Call Diversion services to customers connected to existing non-ISDN based networks which generate the Call Forwarding Inhibit Calling Party Category.***

***Note : Under certain controlled circumstances a call received by an interconnecting network with the specific Call Forwarding Inhibit Calling Party Category sent, may be subject to further Call Diversions if the interconnecting network ensures that the subsequent forwarded call will remain within its own network.***

- Based on the practical implementation of preselection in an interconnecting network, preselection must be applied to the forwarded call.
- To facilitate correct charging of forwarded calls,the Call Forwarding Inhibit Calling Party Category must be considered inconjunction with the number information received from the interconnecting network. The presence of the Call Forwarding Inhibit Calling Party Category also indicates that the call has undergone network interworking to an existing non-ISUP based network or network element and facilitates determination of which fields in the signalling protocol identify the chargeable party for the relevant segment of the call.
- The Malicious Call Trace functionality must also recognise the carriage of additional numbers generated by the Call Diversion services and extract the appropriate number if available.

*Note : Where the Call Forwarding Inhibit Calling Party Category is received, the Malicious Call Trace function in the final destination access network will not be capable of determining the actual calling number.*

## **3.2 Number Related Information**

For these Call Diversion services, number length considerations are primarily related to the forwarding directory number which must be of acceptable length and format. All forwarded numbers should facilitate the inclusion of an override code where such a number format is considered valid in the Australian number plan and implementable.

*Note : Where an interconnecting network does not support the use of Call Forwarding for particular numbers or number formats then the inclusion of that number or number format with an override code may also not be supported.*

## **3.3 Service Access**

These services are explicitly defined for use in an Integrated Service Digital Networks (ISDN) and a GSM mobile network. These services may also be offered in an alternate telephony network or AMPS network.

In the ISDN and GSM network cases the relevant ITU-T ISDN DSS1 or GSM standards for support of these services must be applied.

For the alternate network options, the general implementation supporting this supplementary service description should be considered as the basis for developing any alternate network solutions.

## **3.4 Service Charging Information**

Appropriate customer and intercarrier charging is complicated for the call forwarding services due to the establishment and carriage of additional numbers that are defined during the call set-up.

For the purpose of customer charging the number that identifies the customer that initiated the call forwarding service for the specific recorded segment of the call, must be used as the 'charging to' number.

There can be up to five separate call diversion segments to a call.



## SUPPLEMENTARY DOCUMENT 4

# STAGE 3 SUPPLEMENTARY DESCRIPTION CALL DIVERSION SERVICES

# CALL DIVERSION SERVICES

## TABLE OF CONTENTS

<b>0 GENERAL</b>	<b>1</b>
0.1 Participants	1
<b>1 INTRODUCTION</b>	<b>2</b>
<b>2 REFERENCES</b>	<b>2</b>
<b>3 REQUIREMENTS</b>	<b>2</b>
3.1 Changes to ITU-T Q.732 Clause 2	2



## 0 GENERAL

This document is part of the suite of documents prepared for by the Network Interworking Industry Forum (NIIF) for the purpose of defining the interconnect services and signalling protocol to be available from interconnecting domestic Australian networks.

This document is now being maintained by the ACIF who has assumed responsibility for the self-regulation of the Australian telecommunication industry. Future versions are envisaged to be published as ACIF standards.

This suite of documents is based on specific ITU-T recommendations, which remain copyright to the ITU-T. Each document indicates a base ITU-T recommendation(s) which have been used.

### 0.1 Participants

The NIIF group that developed this document consisted of the following companies and representatives :

	<b>Representative</b>	<b>Company</b>
<i>Chairperson</i>	Les Graf	Ericsson Australia Pty Ltd
<b>Full Time Members</b>		
	Pietro Fu	AAP Telecommunications Pty Ltd
	Guy Ignatius	Vodafone Pty Ltd
<i>Document Editor</i>	Adrian Pizzica	Telstra
	Roger Nicoll/ Jeremy Ginger	Optus Communications Pty Ltd
	Thian Tan	Ericsson Australia Pty Ltd
	Paul Vella	Telstra
<b>Part Time Members</b>		
	Mark Altamore	Alcatel Australia Pty Ltd
	Paul Jancek	BT Australasia Pty Ltd
	Stan Podbreznik	Nortel Australia Pty Ltd

## 1 INTRODUCTION

This document outlines the changes made to the original ITU-T 1993 Q.732 Stage 3 document (Clause 2) to align them with the working adopted by the ACIF for the implementation of this service over the Interconnect ISUP interface.

## 2 REFERENCES

ITU-T Recommendation Q.732 - Clause 2 (1993).

*Note: All underlined text in this document is an excerpt from the above reference.*

GSM 02.82 (Phase 2) Call Forwarding supplementary services - Stage 1

GSM 03.82 (Phase 2) Call Forwarding supplementary services - Stage 2

GSM 09.11 (Phase 2) Signalling interworking for supplementary services

## 3 REQUIREMENTS

### 3.1 Changes to ITU-T Q.732 Clause 2

#### Section 2.1 Definition.

Reference to Call Deflection is removed from the section.

Reference to DSS1 is removed from the section.

The following text is included :

- Call forwarding not reachable (CFNRc)

The **Call forwarding not reachable (CFNRc)** service permits a called mobile subscriber to have the network send all incoming calls, or just those associated with a specific Basic service group, addressed to the called mobile subscriber's directory number, but which is not reachable, to another directory number. The not reachable condition may be due to

- 1.No acknowledgement to paging
- 2.Congestion in Radio resources
- 3.Determined by the VLR for the DETACHED subscribers.
- 4.Determined by the HLR for the DEREGISTERED subscribers

#### Section 2.2.1 General Description.

Reference to Call Deflection is removed from the section.

#### Section 2.2.2 Specific Terminology

**Deflected-to user** is removed.

**Notification subscription option** is removed.

**Redirecting reason** text altered as follows :

**Redirecting reason** - Information sent in the forward direction indicating, in the case of calls undergoing multiple redirections, the reason why the call has been redirected.

**Redirecting Indicator** text altered as follows :

**Redirecting indicator** - Information sent in the forward direction indicating whether the call has been diverted or rerouted and whether or not presentation of redirection information to the calling party is restricted.

**Redirection Reason** text altered as follows :

**Redirection counter** - Information sent in the forward direction indicating the number of redirections which have occurred on a call.

**Redirection Number** is removed.

**Redirection Number restriction indicator** is removed.

The following text has been included in this section :

**CFNRc** - Call forwarding Not reachable(Mobile subscriber).

**HLR** - The home location register is the location register to which a mobile subscriber is assigned for record purposes such as subscriber information.

**VLR** - The visitor location register is the location register, other than HLR, used by a Mobile services switching centre (MSC) to retrieve information for, e.g. handling of calls to or from a roaming mobile station currently located in its area.

**Detached Subscriber** - A mobile subscriber becomes detached subscriber when the subscriber has no radio contact.

**Deregistered Subscriber** - A mobile subscriber becomes deregistered in the VLR after the expiration of a certain period or can be deregistered manually by the MML command.

**MS** - Mobile station.

**MSC** - Mobile switching station.

**GMSC** - Gateway mobile switching station.

**Section 2.3.1 Provision/Withdrawal .**

Section removed.

**Section 2.4.1 Messages**

Text is replaced by:-

**Address complete message**

Optional backward call indicators

**Call progress message**

Event Indicator

Optional backward call indicators

**Initial address message**

Redirecting number

Redirection information

Original called number

**Section 2.4.2 Parameters**

All references and text to **Redirection Number, Redirection restriction indicator, Call Diversion information** and **Generic notification indicator** are removed.

## 2.5.2.1.1. Normal Operation

Point 4 text is replaced with :

~~Call deflection~~ Call Forwarding not reachable immediate response when the early ACM method is used.

## 2.5.2.3 Actions at the outgoing international gateway exchange

Has its titled changed to :-

### 2.5.2.3 Actions at the outgoing gateway exchange

#### **Section 2.5.2.3.1 Normal operation.**

Is replaced by:-

An outgoing gateway exchange checks the following number parameters received in the IAM:

- calling party number;
- original called number;
- redirecting number.

The procedures for the calling party number are as specified for the CLIP/CLIR services.

The same procedures are also applicable for the original called number and the redirecting number.

## Section 2.5.2.4 Actions at the incoming International gateway exchange

Has its titled changed to :-

### 2.5.2.4 Actions at the incoming gateway exchange

#### **Section 2.5.2.4.1 Normal operation.**

Is replaced by:-

An incoming gateway exchange checks the following number parameters received in the IAM:

- calling party number;
- original called number.

The procedures for the calling party number are as specified for the CLIP/CLIR services.

#### **Section 2.5.2.5.1.1 Action at the destination exchange where the diverted-to user is located**

Is replaced by:-

When a destination local exchange receives a diverted call, the called user is alerted.

#### **Section 2.5.2.5.1.2 Actions at the destination exchange performing the diversion**

Part b) item 5) completely removed.

**Section 2.5.2.5.1.2 Table 2-3/Q.732**

Is replaced by:-

A Originally calls B:

	Hop 1	Hop 2*	Hop 3	Hop 4	Hop 5	Hop 6
Number information						
Called party number	B	C	D	E	F	G
Redirecting number		B	C	D	E	F
Original called number		B	B	B	B	B
Redirection information						
Redirection counter		1	2	3	4	5
Redirecting indicator		V	V	V	V	V
Redirecting reason		W	W	W	W	W

V Value = ( call diversion) or (call diversion all redirection info presentation restricted)

W Value = (user busy) or (no reply) or (unconditional) or (deflection during alerting) or (deflection immediate response)

\* *Note Hop 2 not compatible with Blue book working*

**Section 2.5.2.5.1.2 Actions at the destination exchange performing the diversion**

Part c) item (ii) Text replaced with :

ii) Call forwarding no reply and ~~call deflection during alerting~~ call forwarding not reachable

An address complete message with an optional backward call indicator with the indication “call diversion may occur” is returned to the originating exchange. When the no reply timer expires or when the call deflection is invoked:

Option B: The exchange continues in the following manner:

If the number that the call is to be diverted to resides at another exchange, an initial address message is sent. The incoming circuit or line is connected to the chosen outgoing circuit in both directions immediately. The initial address message includes the parameter information in Table 2-3.

The connection to the diverting user is released.

**Section 2.5.2.5.1.2 Actions at the destination exchange performing the diversion**

Part d) - section removed.

**Section 2.5.2.5.1.2 Actions at the destination exchange performing the diversion**

Part e) item (i) text replaced with:

i) Receipt of address complete, call progress or connect message

If an address complete message is received in a diverting exchange, the parameters of the received ACM are transferred in a call progress message. Table 2-4 shows the correct mapping of the information.

Table 2-4/Q.732 included unchanged.

# CALL DIVERSION SERVICES

If a call progress message is received in a diverting exchange, the action to be taken depends on the service causing the diversion:

1) In case of CFU, CFB, ~~CD immediate response~~ and in case of CFNR (option B) and CFNRc and ~~CD during alerting (option B)~~, the call progress message is passed on.

A connect message is mapped into an answer message.

## Section 2.5.2.5.1.2 Table 2-5/Q.732.

Table 2-5/Q.732 Is replaced by:-

Parameter - Sub-parameter or indicator	Handling in a diverting exchange on receipt
Access transport - Called party's sub-address	Discarded or replaced:see 2.6.17
Backward call indicator - Charge indicator	National matter
Called party's number - Odd/even indicator - Nature of address indicator - Internal network number indicator - Numbering plan indicator  - Address signals	Generated:see 2.5.2.5.1.2 b)
Event information - Event indicator	Generated:2.5.2.5.1.2 d) possibly modified:see 2.5.2.5.1.2 e)
Redirecting number - Odd/even indicator - Nature of address indicator - Numbering plan indicator - Address presentation restricted indicator - Address signals	Generated:see 2.5.2.5.1.2 b)
User-to-user information	Discarded or passed on: see Recommendation Q.737.1
Original called number	Generated:see 2.5.2.5.1.2 b)

## Section 2.5.2.5.2.2 Table 2-5/Q.732.

Item (d) text is replaced with :

d) ~~call deflection~~, call forwarding not reachable, the cause value " no user responding" is used (option B only).

### 2.6.2 Call transfer services

Service not supported by Interconnect ISUP.

### 2.6.3 Connected line identification presentation (COLP)

Service not supported by Interconnect ISUP.

**2.6.4 Connected line identification restriction (COLR)**

Service not supported by Interconnect ISUP.

**2.6.5 Calling line identification presentation (CLIP)**

NOTE is removed.

**2.6.7 Closed user group (CUG)**

Service not supported by Interconnect ISUP.

**2.6.8 Conference calling (CONF)**

Service not supported by Interconnect ISUP.

**2.6.12 Three party service (3PTY)**

Service not supported by Interconnect ISUP.

**2.6.13.2 User-to-user signalling, service 2 (UUS2)**

Service not supported by Interconnect ISUP.

**2.6.13.3 User-to-user signalling, service 3 (UUS3)**

Service not supported by Interconnect ISUP.

**2.6.15 Call hold (HOLD)**

Service not supported by Interconnect ISUP.

**2.6.16 Advice of charge (AOC)**

Service not supported by Interconnect ISUP.

**2.6.19 Completion of calls to busy subscriber(CCBS).**

Service not supported by Interconnect ISUP.

**2.6.20 Malicious call identification (MCID)**

Service not supported by Interconnect ISUP.

**2.6.21 Reverse charging (REV)**

Service not supported by Interconnect ISUP.

**2.6.22 Multi-level precedence and preemption (MLPP)**

Service not supported by Interconnect ISUP.

**2.6.23 Private numbering plan (PNP)**

Service not supported by Interconnect ISUP.

**2.6.24 International telecommunication charge card**

Service not supported by Interconnect ISUP.

# CALL DIVERSION SERVICES

## Section 2.7 Interactions with other networks

Text is replaced with:-

In case of interaction with networks which do not provide any notification of the call diversion or call redirection information (e.g. redirection counter) in the signalling system, the call continues according to the basic call procedures.

For Call Diversion services to be effectively interconnected in the Australian domestic environment, the following two specific interworking cases must be supported in every interconnecting network.

These cases identify the interworking of the current Call Diversion services implemented on the Telstra Integrated Digital Network (IDN) using primarily an ATUP signalling system, into an Interconnect ISUP signalling environment.

The IDN ATUP network environment is only capable of signalling a limited amount of Call Diversion information. The Call Diversion information is limited to the definition and inclusion of a specific Calling Party Category field (CPC) :Call Forwarding Inhibit.

**Note - Mapping from Interconnect ISUP to the ATUP signalling system is required but is not detailed in this document.**

### 2.7.1 ATUP to I-ISUP interworking - Setting the parameters at the Call Forwarding Exchange

The first forwarding that the call has undergone

The forwarding exchange must set the Calling Party Category field, the Calling Party Number and the Called Party Number. Their values are as follows :

- 1) Calling Party Category :Inhibit Call Diversion.
- 2) Calling Party Number :This is set as the original called number (B-Party Number).
- 3) Called Party Number :This is set to the number that the call is to be forwarded to.

Figure 1 shows the process diagrammatically.

This process ensures that the customer who has invoked the Call Forwarding service and potentially has preselected an alternate service provider is identifiable in the preceding call segment.

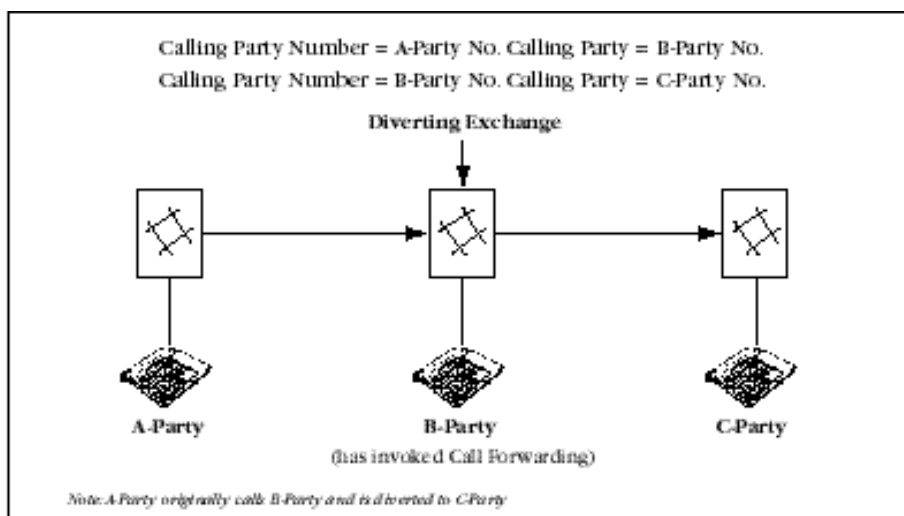

**Figure 1 : Call Forwarding in an ATUP environment**



*The second forwarding that the call has undergone*

No second call forwarding is allowed when the CPC is set to Inhibit Call Diversion.

The Call associated with the Call Forwarding Inhibit Category can be offered to the served user in accordance with normal call procedures for a user without a Call Forwarding service.

**2.7.2 Mapping to I-ISUP**

**2.7.2.1 CASE 1**

The following process is to apply when mapping the above parameters of a forwarded call into the I-ISUP protocol.

*At the interworking exchange*

The interworking exchange must map the Calling Party Category field, the Calling Party Number and the Called Party Number (meaning unmodified) into the relevant I-ISUP fields.

- 1) ATUP Calling Party Category :Inhibit Call Diversion to I-ISUP Calling Party Category : Inhibit Call Diversion.
- 2) ATUP Calling Party Number to I-ISUP Calling Party Number.
- 3) ATUP Called Party Number to I-ISUP Called Party Number.

**Note : The redirecting information, the redirected number and the original called number are not sent.**

Figure 2 shows the process diagrammatically.

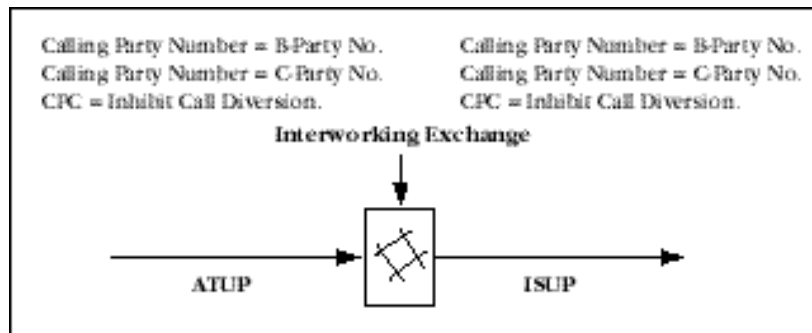

**Figure 2 : Interworking ATUP to I-ISUP**

**2.7.2.2 CASE 2**

The following process is to apply when mapping the above parameters of a forwarded call into the I-ISUP protocol.

*At the interworking exchange*

The interworking exchange must map the Calling Party Category field, the Calling Party Number and the Called Party Number (meaning unmodified) into the relevant I-ISUP fields.

- 1) ATUP Calling Party Category :Inhibit Call Diversion to I-ISUP Calling Party Category : Inhibit Call Diversion.
- 2) ATUP Calling Party Number to I-ISUP Calling Party Number, Original Called Number and the Redirected Number.
- 3) ATUP Called Party Number to I-ISUP Called Party Number.
- 4) Set the Redirection Counter to a value greater than 0 and less than or equal to 5.

# CALL DIVERSION SERVICES

Figure 3 shows the process diagrammatically.

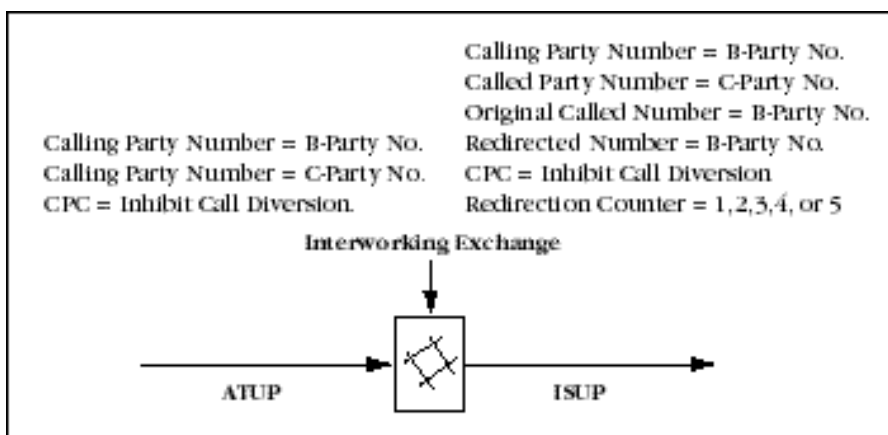

**Figure 3 : Interworking ATUP to I-ISUP**

## 2.7.3 Transitting

An interconnecting network receiving a forwarded call with the Calling Party Category set to Inhibit Call Diversion must transit the relevant Calling Party Category and Calling Party Number unmodified in meaning.

*Note 1: The term unmodified in meaning is used to allow mapping between signalling systems.*

*Note 2: Mapping from Interconnect ISUP to the ATUP signalling system is required but is not detailed in this document.*

## 2.7.4 Terminating the call

The access network of the called party can offer the Call associated with the Call Forwarding Inhibit Category to the called party in accordance with normal call procedures for a user without a Call Diversion service.

## 2.8 Signalling flows

Text is replaced with :

Note - In the following figures 'LE(A)', 'LE(B)' and 'LE(C)' can be interpreted as an exchange within a fixed network or as a GMSC and MSC within a mobile network. However, the Mobile Application Part (MAP) signalling sequences are not shown in these signalling flows.

Figures 2-1 to 2-8 give successful diversion scenarios in case of late ACM procedures.

Figures 2-9 to 2-16 give the scenarios give the scenarios for unsuccessful diversion with late ACM.

Figures 2-17 to 2-24a give successful diversion scenarios in case of early ACM procedures.

Figures 2-25 to 2-32a give the scenarios give the scenarios for unsuccessful diversion with early ACM.

**Figures removed.**

- Figure 2-4/Q.732 is removed.
- Figure 2-6/Q.732 is removed.
- Figure 2-7/Q.732 is removed.
- Figure 2-8/Q.732 is removed.
- Figure 2-12/Q.732 is removed.
- Figure 2-14/Q.732 is removed.
- Figure 2-15/Q.732 is removed.
- Figure 2-16/Q.732 is removed.
- Figure 2-20/Q.732 is removed.
- Figure 2-22/Q.732 is removed.
- Figure 2-23/Q.732 is removed.
- Figure 2-24/Q.732 is removed.
- Figure 2-28/Q.732 is removed.
- Figure 2-30/Q.732 is removed.
- Figure 2-31/Q.732 is removed.
- Figure 2-32/Q.732 is removed.

**Additional Call Forwarding Not Reachable Figures included.**

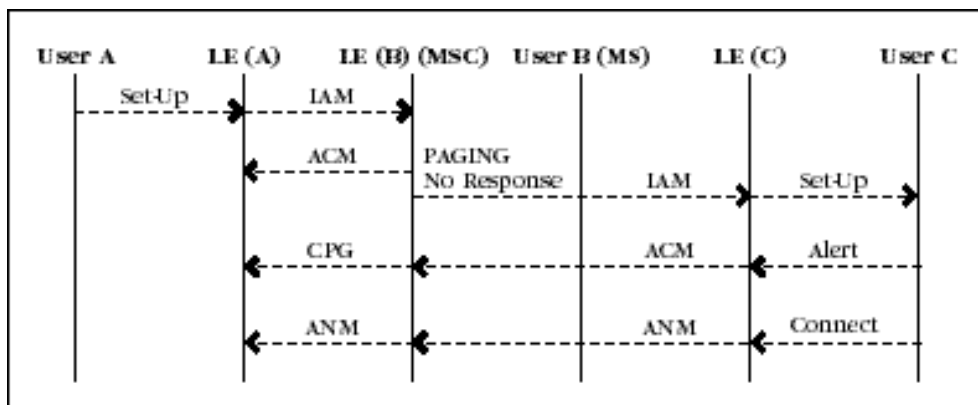

Figure 2-24a - Successful Call forwarding on mobile subscriber not reachable various conditions

- No Paging Response - VLR
- Radio Congestion - VLR
- Not reachable in the VLR :Detached - re-routed by the VLR
- Not reachable in the VLR :Deregistered - re-routed by the HLR

# CALL DIVERSION SERVICES

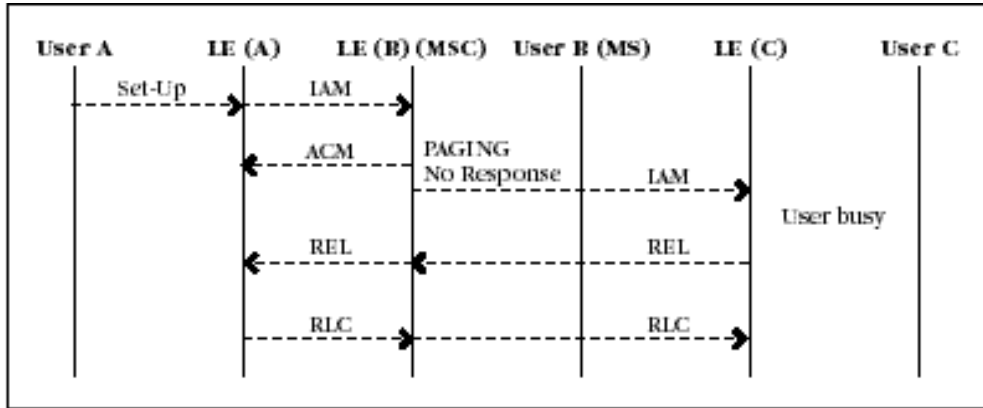

Figure 2-32a - Unsuccessful Call forwarding on mobile subscriber not reachable various conditions

No Paging Response - VLR

Radio Congestion - VLR

Not reachable in the VLR :Detached - re-routed by the VLR

Not reachable in the VLR :Deregistered - re-routed by the HLR

## Section 5 Call deflection (CD)

This section is completely removed.



## SUPPLEMENTARY DOCUMENT 5

# STAGE 1 SUPPLEMENTARY DESCRIPTION CALLING LINE PRESENTATION/RESTRICTION

# CALLING LINE PRESENTATION/RESTRICTION

## TABLE OF CONTENTS

<b>0 GENERAL</b>	<b>1</b>
<b>0.1 Participants</b>	<b>1</b>
<b>1 INTRODUCTION</b>	<b>2</b>
<b>2 REFERENCE</b>	<b>2</b>
<b>3 REQUIREMENTS</b>	<b>2</b>
3.1 General Description	2
3.2 Number Related Information	3
3.3 Service Access	3
3.4 Service Charging Information	3

**0 GENERAL**

This document is part of the suite of documents prepared for by the Network Interworking Industry Forum (NIIF) for the purpose of defining the interconnect services and signalling protocol to be available from interconnecting domestic Australian networks.

This document is now being maintained by the ACIF who has assumed responsibility for the self-regulation of the Australian telecommunication industry. Future versions are envisaged to be published as ACIF standards.

This suite of documents is based on specific ITU-T recommendations, which remain copyright to the ITU-T. Each document indicates a base ITU-T recommendation(s) which have been used.

**0.1 Participants**

The NIIF group that developed this document consisted of the following companies and representatives :

	<b>Representative</b>	<b>Company</b>
<i>Chairperson</i>	Les Graf	Ericsson Australia Pty Ltd
<b>Full Time Members</b>		
	Pietro Fu	AAP Telecommunications Pty Ltd
	Guy Ignatius	Vodafone Pty Ltd
	Adrian Pizzica	Telstra
	Roger Nicoll/ Jeremy Ginger	Optus Communications Pty Ltd
	Thian Tan	Ericsson Australia Pty Ltd
Document Editor	Paul Vella	Telstra
<b>Part Time Members</b>		
	Mark Altamore	Alcatel Australia Pty Ltd
	Paul Jancek	BT Australasia Pty Ltd
	Stan Podbreznik	Nortel Australia Pty Ltd

## 1 INTRODUCTION

This document provides supplementary information for the implementation of the Calling Line Presentation service and the associated Calling Line Identification Restriction service between interconnecting Australian domestic networks.

This document should be read in conjunction with CCITT Recommendation I.251 Section 3 and section 4.

## 2 REFERENCE

CCITT Recommendation I.251 (1988).

*Note : All underlined text in this document is an excerpt from the above reference.*

## 3 REQUIREMENTS

### 3.1 General Description

Calling Line Identification Presentation (CLIP) is a supplementary service offered to the called party which provides the calling party's number, to the called party.

Calling Line Identification Restriction (CLIR) is a supplementary service offered to the calling party to restrict presentation of the calling party's number, to the called party.

When the CLIP service is activated, the access network can provide the called party with the number of the calling party at call set-up on all incoming calls unless CLIR is applicable and activated on the calling party number.

When CLIR is applicable and activated, the destination access network receives a notification that the calling party's number is not allowed to be presented to the called party.

The CLIP service requires suitable Customer Premises Equipment (CPE) to be in use by the Called Party. The provision of this service by an access network does not mean that all customers connected to the access network have or can have this service nor does it mean that the Called Party has been provided with the appropriate CPE.

The CLIR service may support a number of means of activation depending on the Australian regulatory requirements.

Until the regulatory requirement for the CLIP/CLIR service are clarified, the service should support the following invocation options :

- i) opt in/opt out per access ,
- ii) per call opt in/opt out selection as determined by the Calling Party, and
- iii) network invoked restriction of the Calling Party's number.

In the Australian regulatory environment, the default condition associated with the Calling Party number presented at an interconnection point is CLIR (that is, restricted) unless an explicit 'presentation allowed' indication is provided as part of the call set-up.

*Note : Some network services require the access network to forward the calling party number to the called party network interface irrespective of the calling party's restriction requirement. This Calling Line Identification requirement is defined as part of those specific services.*



### 3.2 Number Related Information

The agreement to provide Calling Line Identification between interconnecting Australian domestic networks is a pre-requisite for this service.

The access network to which the calling party belongs, should attempt to ensure that enough digits are transmitted to enable the called party to return the call.

If a transit or third party network agrees to support the CLIP/CLIR service, then transit or third party network must ensure that the CLIP/CLIR indication (Address Presentation Restricted indicator) is transmitted unmodified to the access network of the called party.

The CLIP/CLIR indication (Address Presentation Restricted indicator) once established by the calling party's access network must not be changed or modified by an interconnecting network. However, the CLIP/CLIR indication may not be supported in all interconnecting networks. In this case the relevant indication is discarded.

### 3.3 Service Access

This service is explicitly defined for use in an Integrated Service Digital Networks (ISDN) and a GSM mobile network. The service may also be offered in an alternate telephony network or AMPS network.

In the ISDN and GSM network cases the relevant ITU-T ISDN DSS1 or GSM standard for support of this service must be applied.

For the alternate network options, the general implementation supporting this supplementary service description should be considered as the basis for developing any alternate network solutions.

### 3.4 Service Charging Information

Specific intercarrier charging arrangements may be applied based on detection on the forwarding of the additional calling party information from the access network.





SUPPLEMENTARY DOCUMENT 6

**STAGE 3 SUPPLEMENTARY DESCRIPTION  
CALLING LINE PRESENTATION/RESTRICTION**

# CALLING LINE PRESENTATION/RESTRICTION

## TABLE OF CONTENTS

<b>0 GENERAL</b>	<b>1</b>
0.1 Participants	1
<b>1 INTRODUCTION</b>	<b>2</b>
<b>2 REFERENCES</b>	<b>2</b>
<b>3 REQUIREMENTS</b>	<b>2</b>
3.1 Changes to ITU-T Q.731 Clauses 3,4,5 & 6	2

**0 GENERAL**

This document is part of the suite of documents prepared for by the Network Interworking Industry Forum (NIIF) for the purpose of defining the interconnect services and signalling protocol to be available from interconnecting domestic Australian networks.

This document is now being maintained by the ACIF who has assumed responsibility for the self-regulation of the Australian telecommunication industry. Future versions are envisaged to be published as ACIF standards.

This suite of documents is based on specific ITU-T recommendations, which remain copyright to the ITU-T. Each document indicates a base ITU-T recommendation(s) which have been used.

**0.1 Participants**

The NIIF group that developed this document consisted of the following companies and representatives :

	<b>Representative</b>	<b>Company</b>
<i>Chairperson</i>	Les Graf	Ericsson Australia Pty Ltd
<b>Full Time Members</b>		
	Pietro Fu	AAP Telecommunications Pty Ltd
	Guy Ignatius	Vodafone Pty Ltd
	Adrian Pizzica	Telstra
	Roger Nicoll/ Jeremy Ginger	Optus Communications Pty Ltd
	Thian Tan	Ericsson Australia Pty Ltd
<i>Document Editor</i>	Paul Vella	Telstra
<b>Part Time Members</b>		
	Mark Altamore	Alcatel Australia Pty Ltd
	Paul Jancek	BT Australasia Pty Ltd
	Stan Podbreznik	Nortel Australia Pty Ltd

## 1 INTRODUCTION

This document outlines the changes made to the original ITU-T Q.731 Stage 3 document - Clauses 3,4,5 & 6 to align them with the working adopted by the ACIF for the implementation of this service over the ACIF Interconnect ISUP interface.

## 2 REFERENCES

ITU-T Recommendation Q.731 - Clauses 3,4,5 & 6 (1992)

*Note: All underlined text in this document is an excerpt from the above reference.*

## 3 REQUIREMENTS

### 3.1 Changes to ITU-T Q.731 Clauses 3,4,5 & 6

**Section 3.2.1 General Description:** References to DSS-1 is removed.

**Section 3.2.2 Specific Terminology:** References to DSS-1 is removed.

**Section 3.4 Coding Requirements:** Part i) remains unchanged.  
Part ii) is completely removed.

#### **Section 3.5.2.3 Actions at the Outgoing International Gateway Exchange:**

Title of section is changed to :-

##### 3.5.2.3 Actions at the Outgoing Gateway Exchange:

#### **Section 3.5.2.3.1 Normal operation**

Is replaced by:

If the address presentation restricted indicator of the received calling party number parameter is set to "presentation restricted", the outgoing gateway exchange shall act according to the bilateral agreement between the two networks (see 4.2.1/L.251 and 4.5/L.251). If the address presentation restricted indicator of the received calling party number parameter is set to "address not available", then the calling party number parameter shall be omitted from the initial address message.

The address presentation restricted indicator and the screening indicator shall be transferred transparently.

#### NOTES

1 The address presentation restricted indicator in the calling party number parameters can have the values "presentation allowed" or "presentation restricted".

#### **Section 3.5.2.4 Actions at the Incoming International Gateway Exchange:**

Title of section is changed to :-

##### 3.5.2.4 Actions at the Incoming Gateway Exchange:

#### **Section 3.5.2.4.1 Normal operation**

Is replaced by:-

The nature of address indicator shall be set to "national (significant) number". The address presentation restricted indicator and the screening indicator shall be transferred transparently.

NOTE - As a national option, the incoming gateway exchange may add a prefix to the calling party number. In this case the nature of address indicator shall be set to "unknown".

**3.6.3 Connected line identification presentation (COLP)**

Service not supported by Interconnect ISUP.

**3.6.4 Connected line identification restriction (COLR)**

Service not supported by Interconnect ISUP.

**3.6.7 Closed user group (CUG)**

Service not supported by Interconnect ISUP.

**3.6.8 Conference calling (CONF)**

Service not supported by Interconnect ISUP.

**3.6.10.1 Call forwarding busy (CFB)**

No Impact.

**3.6.10.2 Call forwarding no reply (CFNR)**

No Impact.

**3.6.10.3 Call forwarding unconditional (CFU)**

No Impact.

**Section 3.6.10.A - included as additional text :****3.6.10.A Call forwarding not reachable (CFNRc)**

No Impact.

**3.6.10.4 Call deflection (CD)**

Service not supported by Interconnect ISUP.

**3.6.12 Three-party service (3PTY)**

Service not supported by Interconnect ISUP.

**3.6.13.2 User-to-user signalling, service 2 (UUS2)**

Service not supported by Interconnect ISUP.

**3.6.13.3 User-to-user signalling, service 3 (UUS3)**

Service not supported by Interconnect ISUP.

**3.6.15 Call hold (HOLD)**

Service not supported by Interconnect ISUP.

**3.6.16 Advice of charge (AOC)**

Service not supported by Interconnect ISUP.

**3.6.19 Completion of calls to busy subscriber (CCBS)**

Service not supported by Interconnect ISUP.

**3.6.20 Malicious call identification (MCID)**

Service not supported by Interconnect ISUP.

**3.6.21 Reverse charging (REV)**

Service not supported by Interconnect ISUP.

**3.6.22 Multi-level precedence and preemption (MLPP)**

Service not supported by Interconnect ISUP.

### **3.6.23 Private numbering plan (PNP)**

Service not supported by Interconnect ISUP.

### **3.6.24 International telecommunication charge card**

Service not supported by Interconnect ISUP.

## **Section 4.2.1 General Description:**

Is replaced by:-

The CLIR supplementary service is a supplementary service offered to the calling user to prevent presentation of the calling user's number, and additional address information (e.g. calling party sub-address) if any, to the called user.

When the CLIR supplementary service is applicable and activated, the originating network shall provide the destination network with a notification that the calling party number is not allowed to be presented to the called user. In this case, the calling line identity shall be marked as presentation restricted, in the address presentation restricted indicator(s) of the calling party number parameter when it is passed across the network. In the case of the CLIR supplementary service the calling party's number, and sub-address (if any), shall not be included in the call offered to the called user's installation. It is a function of the user-network interface not to present the identification of the calling user to the called user if the information is marked "presentation restricted" or to override the presentation restricted indication if the called user has an override category (e.g. police).

Information indicating that a subscriber has the CLIR supplementary service facility is available in the exchange to which the subscriber is connected to.

The stage 1 service description is given in Recommendations I.251.3 and I.251.4 and the stage 2 functional capabilities and information flows are given in Recommendation Q.81.3. This stage 3 description of the CLIR supplementary service uses the ISDN user part protocol as defined in Recommendations Q.761-764 and Q.730.

**Section 4.2.2 Specific Terminology:** References to DSS-1 is removed.

### **4.6.3 Connected line identification presentation (COLP)**

Service not supported by Interconnect ISUP.

### **4.6.4 Connected line identification restriction (COLR)**

Service not supported by Interconnect ISUP.

### **4.6.7 Closed user group (CUG)**

Service not supported by Interconnect ISUP.

### **4.6.8 Conference calling (CONF)**

Service not supported by Interconnect ISUP.

### **4.6.10.1 Call forwarding busy (CFB)**

No Impact.

### **4.6.10.2 Call forwarding no reply (CFNR)**



No Impact.

**4.6.10.3 Call forwarding unconditional (CFU)**

No Impact.

**Section 4.6.10.A - included as additional text :**

**4.6.10.A Call forwarding not reachable (CFNRc)**

No Impact.

**4.6.10.4 Call deflection (CD)**

Service not supported by Interconnect ISUP.

**4.6.12 Three-party service (3PTY)**

Service not supported by Interconnect ISUP.

**4.6.13.2 User-to-user signalling, service 2 (UUS2)**

Service not supported by Interconnect ISUP.

**4.6.13.3 User-to-user signalling, service 3 (UUS3)**

Service not supported by Interconnect ISUP.

**4.6.15 Call hold (HOLD)**

Service not supported by Interconnect ISUP.

**4.6.16 Advice of charge (AOC)**

Service not supported by Interconnect ISUP.

**4.6.19 Completion of calls to busy subscriber (CCBS)**

Service not supported by Interconnect ISUP.

**4.6.20 Malicious call identification (MCID)**

Service not supported by Interconnect ISUP.

**4.6.21 Reverse charging (REV)**

Service not supported by Interconnect ISUP.

**4.6.22 Multi-level precedence and preemption (MLPP)**

Service not supported by Interconnect ISUP.

**4.6.23 Private numbering plan (PNP)**

Service not supported by Interconnect ISUP.

**4.6.24 International telecommunication charge card**

Service not supported by Interconnect ISUP.

**Section 5 Connected Line identification presentation (COLP):-**

Section 5 is completely removed.

**Section 6 Connected Line identification restriction (COLR):-**

Section 6 is completely removed.





## SUPPLEMENTARY DOCUMENT 7

# APPLICATION OF THE MESSAGE TRANSFER PART FOR NATIONAL INTERCONNECT

## TABLE OF CONTENTS

<b>0. GENERAL</b>	<b>1</b>
0.1. Participants	1
<b>1. INTRODUCTION</b>	<b>2</b>
<b>2. REFERENCES</b>	<b>2</b>
<b>3. REQUIREMENTS</b>	<b>2</b>
3.1. Changes to ITU-T Recommendation Q.701 - Functional Description of the Message Transfer Part (MTP) of Signalling System No. 7	2
3.2. Changes to ITU-T Recommendation Q.702 - Signalling Data Link	2
3.3. Changes to ITU-T Recommendation Q.703 - Signalling Link	3
3.4. Changes to ITU-T Recommendation Q.704 - Signalling Network Functions and Messages	3
3.5. Changes to ITU-T Recommendation Q.705 - Signalling Network Structure	4
3.6. Changes to ITU-T Recommendation Q.706 - Message Transfer Part Signalling Performance	4
3.7. Changes to ITU-T Recommendation Q.707 - Testing and Maintenance	4
3.8. Changes to ITU-T Recommendation Q.708 - Numbering of International Point Codes	4
3.9. Changes to ITU-T Recommendation Q.709 - Hypothetical Signalling Reference Connection	4

## 0. GENERAL

This document is part of the suite of documents prepared for by the Network Interworking Industry Forum (NIIF) for the purpose of defining the interconnect services and signalling protocol to be available from interconnecting domestic Australian networks.

This document is now being maintained by the ACIF who has assumed responsibility for the self-regulation of the Australian telecommunication industry. Future versions are envisaged to be published as ACIF standards.

This suite of documents is based on specific ITU-T recommendations, which remain copyright to the ITU-T. Each document indicates a base ITU-T recommendation(s) which have been used.

### 0.1. Participants

The NIIF group that developed this document consisted of the following companies and representatives :

	<b>Representative</b>	<b>Company</b>
<i>Chairperson</i>	Les Graf	Ericsson Australia Pty Ltd
<b>Full Time Members</b>		
	Pietro Fu	AAP Telecommunications Pty Ltd
	Philip Fong / Guy Ignatius	Vodafone Pty Ltd
	Adrian Pizzica	Telstra
<i>Document Editor</i>		
	Roger Nicoll / Jeremy Ginger	Optus Communications Pty Ltd
	Thian Tan	Ericsson Australia Pty Ltd
	Paul Vella	Telstra
<b>Part Time Members</b>		
	Mark Altamore	Alcatel Australia Pty Ltd
	Paul Jancek	BT Australasia Pty Ltd
	Stan Podbreznik	Nortel Australia Pty Ltd

## 1. INTRODUCTION

This document describes the national interconnect implementation of the Message Transfer Part (MTP) of Signalling System No.7 recommended for use by the ACIE.

The MTP implementation described by this document is recommended for use between interconnecting national switch operators. The choice and implementation of the User Parts is beyond the scope of this document.

Any clauses of CCITT Recommendations Q.701 to Q.709,1988, which are not mentioned in this document are deemed to be fully applicable for national interconnect. These clauses do not require any clarification.

## 2. REFERENCES

CCITT Recommendations Q.701 to Q.709,1988.

## 3. REQUIREMENTS

### 3.1. Changes to ITU-T Recommendation Q.701 - Functional Description of the Message Transfer Part (MTP) of Signalling System No. 7

Section 2.2.2 Only 64 kbit/s signalling data links will be used.

Section 5 The MTP is required to carry MSUs of up to 272 octets in length

Section 7.2.6 The MTP will support MSUs up to 272 octets. Analysis of the LSSU D-bit is not required on signalling links.

### 3.2. Changes to ITU-T Recommendation Q.702 - Signalling Data Link

1.3 The 64 kbit/s signalling data link will be delivered as a channel in a 2048 kbit/s digital multiplex signal as defined in Recommendation G.704.

1.4 Analogue signalling data links will not be used.

1.8 Multiplex structures or switchable functions used to connect the signalling data link within an exchange are implementation dependent.

2.1.2,2.1.3,2.2.1,2.2.2,2.2.3 Only 64 kbit/s signalling data links will be used.

5.1 Signalling data links will reside in time slot 1.

5.2 8448 kbit/s digital paths will not be used.

5.3 1544 kbit/s digital paths will not be used.

5.5 Signalling data links established over data circuits will not be used.

6 Analogue signalling data links will not be used.

### 3.3. Changes to ITU-T Recommendation Q.703 - Signalling Link

1.4.1 Only the basic method of error correction will be used.

1.4.3 The preventive cyclic retransmission method will not be used.

6 The preventive cyclic retransmission method will not be used.

**3.4. Changes to ITU-T Recommendation Q.704 - Signalling Network Functions and Messages**

- 1.4.1 Only basic method error correction will be used.
- 2.2.3 The standard label structure of length 32 bits will be used. The signalling point code value of zero is reserved and will not be allocated.
- 2.3.5 Multiple congestion levels will not be used.
- 2.3.5.2 Multiple congestion levels will not be used.
- 3.3.5.2 Signalling route restricted will not be used.
- 3.8.2,3.8.3,3.8.4 Just one level of congestion onset and abatement will be used. Multiple levels of congestion are not used.
- 3.8.5.2 The signalling routeset congestion test is not used.
- 4.7 Signalling route restriction is not used.
- 6.2.3 iii) The transfer restricted procedure is not used.
- 11.2.4,11.2.5 Multiple congestion levels are not used.
- 12.6 Automatic allocation of signalling data links will not be used.
- 13.4 Transfer Restricted is not used.
- 13.7 Multiple congestion levels are not used.
- 13.8 Multiple congestion levels are not used.
- 13.9 The signalling routeset congestion test is not used.
- 14.2.1 The same User Part service indicators will apply to the national network as used in the international network.
- 14.2.2 All messages sent on the MTP must use a network indicator of "national network".
- 15.9 Transfer Restricted message is not used.
- 15.13 Signalling Data Link Connection Order message is not used.
- 15.14 Signalling Data Link Connection Acknowledgement message is not used.
- 15.16 Signalling Routeset Congestion Test message is not used.

**3.5. Changes to ITU-T Recommendation Q.705 - Signalling Network Structure**

7. Signalling network structure is a matter for bilateral discussion. Specifically the use of STPs, multiple links in a linkset, load-sharing across linksets, and the use of priority-ordered linksets is a matter for bilateral agreement.

**3.6. Changes to ITU-T Recommendation Q.706 - Message Transfer Part Signalling Performance**

No variations.

**3.7. Changes to ITU-T Recommendation Q.707 - Testing and Maintenance**

No variations.

## **3.8. Changes to ITU-T Recommendation Q.708 - Numbering of International Point Codes**

1. International Signalling Point Codes are not recommended for national interconnect. National signalling point codes will be used.
2. National signalling point codes are allocated as decimal numbers, from the range 1-16,383. Signalling Point Code 0 is reserved. Point code allocations are currently administered by Telstra.

## **3.9. Changes to ITU-T Recommendation Q.709 - Hypothetical Signalling Reference Connection**

No variations.





## SUPPLEMENTARY DOCUMENT 8

# STAGE 1 SUPPLEMENTARY DESCRIPTION SPEECH BEARER SERVICE CATEGORY

## TABLE OF CONTENTS

<b>0 GENERAL</b>	<b>1</b>
0.1 Participants	1
<b>1 INTRODUCTION</b>	<b>2</b>
<b>2 REFERENCE</b>	<b>2</b>
<b>3 REQUIREMENTS</b>	<b>2</b>
3.1 General Description	2
3.2 Number Related Information	2
3.3 Service Access	2
3.4 Service Charging Information	2

**0 GENERAL**

This document is part of the suite of documents prepared for by the Network Interworking Industry Forum (NIIF) for the purpose of defining the interconnect services and signalling protocol to be available from interconnecting domestic Australian networks.

This document is now being maintained by the ACIF who has assumed responsibility for the self-regulation of the Australian telecommunication industry. Future versions are envisaged to be published as ACIF standards.

This suite of documents is based on specific ITU-T recommendations, which remain copyright to the ITU-T. Each document indicates a base ITU-T recommendation(s) which have been used.

**0.1 Participants**

The NIIF group that developed this document consisted of the following companies and representatives :

	<b>Representative</b>	<b>Company</b>
<i>Chairperson</i>	Les Graf	Ericsson Australia Pty Ltd
<b>Full Time Members</b>		
	Pietro Fu	AAP Telecommunications Pty Ltd
	Guy Ignatius	Vodafone Pty Ltd
	Adrian Pizzica	Telstra
	Roger Nicoll/ Jeremy Ginger	Optus Communications Pty Ltd
	Thian Tan	Ericsson Australia Pty Ltd
Document Editor	Paul Vella	Telstra
<b>Part Time Members</b>		
	Mark Altamore	Alcatel Australia Pty Ltd
	Paul Jancek	BT Australasia Pty Ltd
	Stan Podbreznik	Nortel Australia Pty Ltd

## 1 INTRODUCTION

This document provides supplementary information for the implementation of the Speech bearer service category between interconnecting Australian domestic networks.

This document should be read in conjunction with ITU-T Recommendation I.231 Section 2.

## 2 REFERENCE`

ITU-T Recommendation I.231 (1988).

*Note : All underlined text in this document is an excerpt from the above reference.*

## 3 REQUIREMENTS

### 3.1 General Description

This bearer service category is intended to support speech.

The digital signal at the S/T reference point shall conform to Recommendation G.711 (A-law or ~~μ-law~~). The network may use processing techniques appropriate for speech such as analogue transmission, echo control, and low bit-rate voice encoding.

All domestic Australian networks must use A-law encoding for this service.

### 3.2 Number Related Information

The Speech bearer service category does not require the use of any new numbers or codes.

No additional network interconnection information specific to this bearer service category, is required in the call set-up process.

### 3.3 Service Access

Selection of this bearer service category must be explicitly supported by an Integrated Service Digital Networks (ISDN) or a GSM Mobile networks. In these cases the relevant ITU-T ISDN Digital Signalling System 1 (DSS1) or GSM standards for selecting this bearer service category must be applied.

### 3.4 Service Charging Information

Specific intercarrier charging arrangements may be applied based on detection of this bearer service category.



SUPPLEMENTARY DOCUMENT 9

**STAGE 1 SUPPLEMENTARY DESCRIPTION  
USER-TO-USER SIGNALLING**

# USER-TO-USER SIGNALLING

## TABLE OF CONTENTS

<b>0 GENERAL</b>	<b>1</b>
0.1. Participants	1
<b>1. INTRODUCTION</b>	<b>2</b>
<b>2. REFERENCES</b>	<b>2</b>
<b>3. REQUIREMENTS</b>	<b>2</b>
3.1. General Description	2
3.2. Number Related Information	3
3.3. Service Access	3
3.4. Service Charging Information	3

**0. GENERAL**

This document is part of the suite of documents prepared for by the Network Interworking Industry Forum (NIIF) for the purpose of defining the interconnect services and signalling protocol to be available from interconnecting domestic Australian networks.

This document is now being maintained by the ACIF who has assumed responsibility for the self-regulation of the Australian telecommunication industry. Future versions are envisaged to be published as ACIF standards.

This suite of documents is based on specific ITU-T recommendations, which remain copyright to the ITU-T. Each document indicates a base ITU-T recommendation(s) which have been used.

**0.1. Participants**

The NIIF group that developed this document consisted of the following companies and representatives :

	<b>Representative</b>	<b>Company</b>
<i>Chairperson</i>	Les Graf	Ericsson Australia Pty Ltd
<b>Full Time Members</b>		
	Pietro Fu	AAP Telecommunications Pty Ltd
	Philip Fong / Guy Ignatius	Vodafone Pty Ltd
	Adrian Pizzica	Telstra
<i>Document Editor</i>		
	Roger Nicoll / Jeremy Ginger	Optus Communications Pty Ltd
	Thian Tan	Ericsson Australia Pty Ltd
	Paul Vella	Telstra
<b>Part Time Members</b>		
	Mark Altamore	Alcatel Australia Pty Ltd
	Paul Jancek	BT Australasia Pty Ltd
	Stan Podbreznik	Nortel Australia Pty Ltd

## 1. INTRODUCTION

This document outlines the changes made to the original ITU-T 1992 I.257.1 Stage 1 document to align them with the working adopted by the ACIF for the implementation of this service over the ACIF Interconnect ISUP interface.

For interconnect purposes service 1 with implicit service requests has been selected.

## 2. REFERENCES

ITU-T Recommendation I.257.1,(1992).

*Note: All underlined text in this document is an excerpt from the above reference.*

## 3. REQUIREMENTS

### 3.1. General Description

User-to-User Signalling (UUS) allows the user to send/receive a limited amount of user generated information to/from another user-network interface. This information is passed transparently (i.e. without modification of contents) through the network. Normally, the network will not interpret or act upon this information.

Services 1, 2, and 3 allows the transmission of 128 octets per message as a maximum.

Note - During an interim period of time, some networks may support 32 octets on one or more of the services. 32 octets will always be supported. Restrictions may apply to calls requesting UUI of more than 32 octets.

Limitations are also placed on the number of messages per time unit for service 3. The flow control of each direction shall be operated independently.

The user can transfer UUI in different phases of the call depending on the service(s) to which the user subscribes. These are:

- Service 1: the transfer of UUI during the set-up and clearing phases of a call, with UUI embedded within call control messages;

- Service 2: the transfer of UUI during the set-up phase of call, transferred independently of call control messages. From the sender's point of view UUI is sent prior to the active phase of the call (i.e. prior to the acceptance of the call at the distant exchange). This same UUI may, as a service provider option, be received by the terminating exchange and delivered to the user during the active phase of the call.

- Service 3: the transfer of UUI during the active phase of a call, transferred independently of call control messages.

The user can transfer UUI during the set-up and clearing phases of a call, with UUI embedded within call control messages. This is known as service 1 in I.257.1

In a point-to-multipoint arrangement at the called party the following Service 1 UUI transfer is allowed:

- in the forward direction, UUI will only be accepted if it is contained in either the initial set-up or the first clearing message. In the case of premature clearing, UUI will be delivered to terminals which have at this point in time already acknowledged the call;



- in the backward direction, UUI can be sent from the called user to the calling user with the alerting indication;

- if the network has knowledge that contention may occur (i.e. multiple alerting messages) on the called user's interface, the network should not allow UUI to be sent in the alerting indication to the calling user. If the network does not know the user's configuration, the network should send the UUI in the alerting indication to the calling user;

- if the call never reaches the active phase (e.g. in case of call rejection), several call rejection causes may be received from the called user. In this case, the network shall choose the UUI (if any) associated with the call rejection cause which is selected to be sent to the calling user. If multiple responses with the same rejection cause are received, the first one shall be sent to the calling user.

UUS service 2 shall be applicable only to point-to-point arrangements.

### **3.2. Number Related Information**

The User-to-User Signalling (UUS) service category does not require the use of any new numbers or codes.

No additional network interconnection information specific to this bearer service category, is required in the call set-up process.

### **3.3. Service Access**

This service is explicitly defined for use in an Integrated Digital Service Network (ISDN) and a GSM mobile network. The service may also be offered in an alternate telephony network or an AMPS network.

In the ISDN and GSM network cases the relevant ITU-T ISDN Digital Signalling System 1 (DSS1) or GSM standards for support of this service must be applied.

For the alternate network options, the general implementation supporting this supplementary service description should be considered as the basis for developing any alternate network solutions.

### **3.4. Service Charging Information**

Specific intercarrier charging arrangements may be applied based on detection of this bearer service category.





SUPPLEMENTARY DOCUMENT 10

**STAGE 3 SUPPLEMENTARY DESCRIPTION  
USER-TO-USER SIGNALLING**

# USER-TO-USER SIGNALLING

## TABLE OF CONTENTS

<b>0 GENERAL</b>	<b>4</b>
0.1. Participants	4
<b>1. INTRODUCTION</b>	<b>5</b>
<b>2. REFERENCES</b>	<b>5</b>
<b>3. REQUIREMENTS</b>	<b>5</b>
3.1.Changes to ITU-T Recommendation Q.737 Clause 1 (1993)	5

**0 GENERAL**

This document is part of the suite of documents prepared for by the Network Interworking Industry Forum (NIIF) for the purpose of defining the interconnect services and signalling protocol to be available from interconnecting domestic Australian networks.

This document is now being maintained by the ACIF who has assumed responsibility for the self-regulation of the Australian telecommunication industry. Future versions are envisaged to be published as ACIF standards.

This suite of documents is based on specific ITU-T recommendations, which remain copyright to the ITU-T. Each document indicates a base ITU-T recommendation(s) which have been used.

**0.1. Participants**

The NIIF group that developed this document consisted of the following companies and representatives :

	<b>Representative</b>	<b>Company</b>
<i>Chairperson</i>	Les Graf	Ericsson Australia Pty Ltd
<b>Full Time Members</b>		
	Pietro Fu	AAP Telecommunications Pty Ltd
	Philip Fong / Guy Ignatius	Vodafone Pty Ltd
	Adrian Pizzica	Telstra
<i>Document Editor</i>	Roger Nicoll / Jeremy Ginger	Optus Communications Pty Ltd
	Thian Tan	Ericsson Australia Pty Ltd
	Paul Vella	Telstra
<b>Part Time Members</b>		
	Mark Altamore	Alcatel Australia Pty Ltd
	Paul Jancek	BT Australasia Pty Ltd
	Stan Podbreznik	Nortel Australia Pty Ltd

## 1. INTRODUCTION

This document outlines the changes made to the original ITU-T 1993 Q.737 Stage 3 document (Clause 1) to align them with the working adopted by the ACIF for the implementation of this service over the ACIF Interconnect ISUP interface.

For interconnect purposes service 1 with implicit service requests has been selected.

## 2. REFERENCES

ITU-T Recommendation Q.737 (Clause 1) (1993).

*Note: All underlined text in this document is an excerpt from the above reference.*

## 3. REQUIREMENTS

### 3.1. Changes to ITU-T Recommendation Q.737 Clause 1, 1993

#### Section 1.1.4 Coding requirements

Is altered to read as follows.

User-to-user information is carried in the user-to-user information parameter of variable length which may be contained in the initial address, address complete, ~~call progress, connect, answer, segmentation,~~ and release messages.

~~An explicit request for service 1 is carried/n the user-to-user indicators parameter in the initial address message. An explicit indication of acceptance or rejection of service 1 is carried in the user-to-user indicators parameter in the address complete, call progress, answer, connect, or release messages.~~

The network indication when user-to-user information is discarded from the initial address message according to 1.1.5.2.5.2.3, is carried in the user-to-user indicators parameter in the first appropriate backward message, e.g. the address complete message.

#### Section 1.1.5.2.1.1.2 Explicit Service Request

Is completely removed.

#### Section 1.1.5.2.1.1.3 Transfer of user-to-user information

Is altered to read as follows.

User-to-user information may be contained in any of the messages that may be transferred in the call set-up and call release phases, ~~independently of whether the service is requested implicitly or explicitly,~~ provided that the ~~explicit service 1 has not been rejected or the request for the implicit service 1 has not been discarded.~~ ~~If the explicit request for service 1 is included in the initial address message, then any user-to-user information included shall be considered part of the explicit service.~~

The user-to-user information parameter received at the distant exchange in a release message is passed to the call control for the remote user. In the case of simultaneous clearing of the call the release message may not reach the distant exchange and the user-to-user information will be lost.

#### Section 1.1.5.2.1.2 Exceptional procedures

Is altered to read as follows.

The originating exchange shall be able to interpret the discard and rejection indications generated by any succeeding exchange and act accordingly (see 1.1.5.2.5.2).

**Section 1.1.5.2.2.2 Exceptional procedures**

Is altered to read as follows.

The information which is generated as described in 1.1.5.2.5.2 is passed unchanged. Rejection of an explicit service request or discarding of user-to-user information (see 1.1.5.2.5.2) can also take place in the transit exchange.

**Section 1.1.5.2.5.2.2 Rejection of explicit service request**

Is completely removed.

**Section 1.1.5.2.5.2.3 Discard of user-to-user information**

Is altered to read as follows.

If for the implicit service 1 the network is unable to pass the user-to-user information in the initial address message, for example, because the network does not support the service, then the user-to-user indicators parameter is included in the first appropriate backward message, e.g. an address complete message, with the network discard indicator coded "UII discarded by the network". However, this indication cannot be guaranteed as a segmentation message carrying user-to-user information can be discarded without any indication when peer-to-peer interworking with Q.767 ISUP takes place. If the network is unable to pass the user-to-user information parameter in any other message, no indication is provided.

If for the explicit service 1 the network is unable to pass the user-to-user information in any message, no indication is provided.

The user may not be able to interpret incoming user-to-user information. In such situations, the user should discard this information without disrupting normal call handling. No specific signalling is provided by the network to accommodate this situation.

**Section 1.1.6.1 Call Waiting (CW)**

Service not supported by interconnect ISUP.

**Section 1.1.6.2 Call transfer services**

Service not supported by interconnect ISUP.

**Section 1.1.6.3 Connected Line Identification Presentation (COLP)**

Service not supported by interconnect ISUP.

**Section 1.1.6.4 Connected Line Identification Restriction (COLR)**

Service not supported by interconnect ISUP.

**Section 1.1.6.7 Closed User Group (CUG)**

Service not supported by interconnect ISUP.

**Section 1.1.6.7 Conference Calling (CONF)**

Service not supported by interconnect ISUP.

**Section 1.1.6.10.1 Call Forwarding Busy (CFB)**

Is altered to read as follows.

If the forwarding user does not subscribe to service 1 or inhibits service 1 on forwarded calls, two cases exist:

a) If service 1 was explicitly requested as "essential", the call is cleared. The cause is "facility rejected".

b) If service 1 was implicitly requested or explicitly requested as “non-essential”, the forwarding exchange will not include the user-to-user information parameter in the initial address message used to set up the forwarded leg of the call. Also, if the user-to-user indicators parameter is included in the outgoing initial address message, service 1 will be indicated as “no information”. The procedures specified in 1.1.5.2.5.2 will ensure that the calling user is informed, if applicable, of the lack of user-to-user signalling capability.

If the forwarding user does not subscribe to service 1 or inhibits service 1 on forwarded calls and then if service 1 was implicitly requested, the forwarding exchange will not include the user-to-user information parameter in the initial address message used to set up the forwarded leg of the call. Also, if the user-to-user indicators parameter is included in the outgoing initial address message, service 1 will be indicated as “no information”. The procedures specified in 1.1.5.2.5.2 will ensure that the calling user is informed, if applicable, of the lack of user-to-user signalling capability.

If the forwarding user subscribes to service 1 and does not inhibit it on forwarded calls, the forwarding exchange will try to supply the service requested. This will be accomplished by requesting service 1 in the outgoing initial address message using the same request information that was contained in the original initial address message. If the attempt is successful, user-to-user information transfer will be available between the calling user and the forwarded-to user.

In the case where a user determined user busy condition exists, the user-to-user indicators and/or user-to-user information are also delivered to the forwarding user when the call is offered.

## **Section 1.1.6.10.2 Call Forwarding No Reply (CFNR)**

Is altered to read as follows.

The implicit or explicit request for service 1 is sent to the forwarding user. If the forwarding user does not subscribe to service 1, inhibits service 1 on forwarded calls, or explicitly rejects an explicit request, two cases exist:

a) If service 1 was explicitly requested as “essential”, the call is cleared. The cause is “facility rejected”.

b) If service 1 was implicitly requested or explicitly requested as “non-essential”, the forwarding exchange will not include the user-to-user information parameter in the initial address message used to set up the forwarded leg of the call. Also, if the user-to-user indicators parameter is included in the outgoing initial address message, service 1 will be indicated as “no information”. The procedures specified in 1.1.5.2.5.2 will ensure that the calling user is informed, if applicable, of the lack of user-to-user signalling capability.

The implicit request for service 1 is sent to the forwarding user. If the forwarding user does not subscribe to service 1 or inhibits service 1 on forwarded calls, then if service 1 was implicitly requested, the forwarding exchange will not include the user-to-user information parameter in the initial address message used to set up the forwarded leg of the call. Also, if the user-to-user indicators parameter is included in the outgoing initial address message, service 1 will be indicated as “no information”. The procedures specified in 1.1.5.2.5.2 will ensure that the calling user is informed, if applicable, of the lack of user-to-user signalling capability.

If the forwarding user subscribes to service 1, and does not inhibit it on forwarded calls and does not explicitly reject the request, the action is taken as described under Call Forwarding Busy (see 1.1.6.10.1).



**Section 1.1.6.10.A Call Forwarding Not Reachable (CFNRc)**

As Call Forwarding No Reply (see 1.1.6.10.1).

**Section 1.1.6.12 Three-Party Service (3PTY)**

Service not supported by interconnect ISUP.

**Section 1.6.13.2 User-to-User Signalling, service 2 (UUS2)**

Is completely removed.

**Section 1.1.6.13.3 User-to-User Signalling, service 3 (UUS3)**

Is completely removed.

**Section 1.1.6.15 Call Hold (HOLD)**

Service not supported by interconnect ISUP.

**Section 1.1.6.16 Advice of Charge (AOC)**

Service not supported by interconnect ISUP.

**Section 1.1.6.19 Completion of calls to busy subscriber (CCBS)**

Service not supported by interconnect ISUP.

**Section 1.1.6.20 Malicious call identification (MCID)**

Service not supported by interconnect ISUP.

**Section 1.1.6.21 Reverse Charging (REV)**

Service not supported by interconnect ISUP.

**Section 1.1.6.22 Multi-Level Precedence and Preemption (MLPP)**

Service not supported by interconnect ISUP.

**Section 1.1.6.23 Private Numbering Plan (PNP)**

Service not supported by interconnect ISUP.

**Section 1.1.6.24 International Telecommunication Charge Card**

Service not supported by interconnect ISUP.

**Section 1.1.7 Interaction with other networks**

In the case of call control interworking from a network supporting the User-to-User Signalling service 1 to

- a non-No. 7 network;

- a No. 7 network, not ISUP;

- a No. 7 network not supporting the service.

The ISDN exchange receiving an initial address message including an implicit or explicit service request retains knowledge of this request and returns signalling information about the User-to-User Signalling service as specified in Table 1-1.

**TABLE 1-I/Q.737**

**Service 1 rejection in case of interworking**

<u>Interworking network</u>	<u>Implicit request</u>	<u>Non-essential request</u>	<u>Essential request</u>
<u>Non-SS No. 7 network</u>	<u>ACM; interworking ind.: interw. encountered</u>	<u>ACM; UUI inc.: service 1 not provided</u>	<u>Rel #29 + diagnostics (Note 1)</u>
<u>SS No. 7 network, not ISUP</u>	<u>ACM; ISDN user part inc.: ISUP not all the way</u>	<u>ACM; UUI inc.: service 1 not provided</u>	<u>Rel #29 + diagnostics (Note 1)</u>
<u>SS No. 7 network not supporting the service</u>	<u>ACM or CON; UUI inc.: UUI discarded (Note 2)</u>	<u>ACM or CON; UUI inc.: service 1 not provided (Note 3)</u>	<u>Rel #29 + diagnostics (Note 1 and 3)</u>

NOTES

1 The diagnostics field contains the user-to-user indicators parameter name and length.

2 If the UUI in the IAM has been discarded, the user-to-user indicators parameter contains "UUI discarded by the network".

If it is detected that the originating exchange has performed segmentation by sending UUI in the additional segment, and a subsequent exchange knows that the segmentation procedure is not supported by the succeeding network, the latter exchange will code the user-to-user indicators parameter as "UUI discarded by the network". This knowledge may be obtained by reception of a confusion message indicating that the segmentation message has been discarded.

3 A transit or intentional gateway exchange may have to generate service rejection in case a confusion message is received indicating that the user-to-user indicators requesting the service are not supported by the succeeding network.

Two ISDN networks that interwork may have to retain knowledge of the service request until it is clear whether both can support the service.

**Section 1.1.8 Signalling flows**

Figure 1-1 shows a successful use of UUS service 1 when implicitly requested in a point-to-point configuration. Figure 1-2 shows a successful use of UUS service 1 when explicitly requested in a point-to-point configuration.

The following Notes apply to Figures 1-1 and 1-2:

NOTES

1 In cases where an ALERTING indication is carried by a call progress message, the user-to-user indicators parameter and/or user-to-user information parameter may be transported in the call progress message.

2 In cases where the called user is an automatic answering terminal, the user-to-user indicators parameter and/or user-to-user information parameter may be transported in a connect message.

In cases where the called user is an automatic answering terminal, the user-to-user indicators parameter and/or user-to-user information parameter may be transported in a connect message.

The following abbreviations are used in Figures 1-1 and 1-2:

Figure 1-1/Q.737 remains unchanged.

Figure 1-2/Q.737 is completely removed.

Table altered as follows :

<u>Abbreviation</u>	<u>User-to-user indicator values</u>
<del>ni</del>	<del>No information</del>
<del>rnc</del>	<del>Requested, non-essential</del>
<del>re</del>	<del>Requested, essential</del>
<del>p</del>	<del>Provided</del>
<del>np</del>	<del>Not provided</del>
<u>Abbreviation</u>	<u>Parameter name</u>
UUI	User-to-user information
<del>UUI ind.</del>	<del>User-to-user indicators</del>
<u>Abbreviation</u>	<u>Message name</u>
ACM	Address complete
ANM	Answer
IAM	Initial address
REL	Release
RLC	Release complete

The messages shown with dashed lines are not part of the ISDN user part protocol and are for information only. For detailed information on the access protocol user-to-user procedures the ISDN access protocol Recommendations should be examined.

**Section 1.2 User-to-User Signalling service 2**

Is completely removed.

**Section 1.3 User-to-User Signalling service 3**

Is completely removed.





SUPPLEMENTARY DOCUMENT 11

**INTERCONNECT DIAL PLAN**

# INTERCONNECT DIAL PLAN

## TABLE OF CONTENTS

<b>0 GENERAL</b>	<b>1</b>
0.1 Participants	1
<b>1 INTERCONNECT DIAL PLAN</b>	<b>2</b>

**0 GENERAL**

This document is part of the suite of documents prepared for by the Network Interworking Industry Forum (NIIF) for the purpose of defining the interconnect services and signalling protocol to be available from interconnecting domestic Australian networks.

This document is now being maintained by the ACIF who has assumed responsibility for the self-regulation of the Australian telecommunication industry. Future versions are envisaged to be published as ACIF standards.

This suite of documents is based on specific ITU-T recommendations, which remain copyright to the ITU-T. Each document indicates a base ITU-T recommendation(s) which have been used.

This document indicates the recommended technique for passing information between networks that is necessary for end-to-end operation but is not included in the signalling elements of the Interconnect ISUP. This is achieved by adding additional digits before the digits dialled, hence the title, 'Interconnect Dial Plan'. It is possible the future versions of the Interconnect ISUP, some of this information may be carried within the signalling.

**0.1 Participants**

The NIIF group that developed this document consisted of the following companies and representatives :

	<b>Representative</b>	<b>Company</b>
<i>Chairperson</i>	Les Graf	Ericsson Australia Pty Ltd
<b>Full Time Members</b>		
	Pietro Fu	AAP Telecommunications Pty Ltd
	Guy Ignatius	Vodafone Pty Ltd
	Adrian Pizzica	Telstra
	Roger Nicoll/ Jeremy Ginger	Optus Communications Pty Ltd
	Thian Tan	Ericsson Australia Pty Ltd
<i>Document Editor</i>	Paul Vella	Telstra
<b>Part Time Members</b>		
	Mark Altamore	Alcatel Australia Pty Ltd
	Paul Jancek	BT Australasia Pty Ltd
	Stan Podbreznik	Nortel Australia Pty Ltd

# INTERCONNECT DIAL PLAN

## 1 INTERCONNECT DIAL PLAN

**Table 1 - Dial Plan for Interconnect ISUP**

CALL CASE	CALL TYPE	USER NO. DIALLED (1)	POI ADDRESS DIGITS (1)
1	Override call	14XY+0+NSN 14XY+0011+CC+NSN 14XY+LN	14XY+0+NSN 14XY+0011+CC+NSN 14XY+0+NSN
2	Preselection	0+NSN 0011+CC+NSN LN	14XY+5+0+NSN 14XY+5+0011+CC+NSN 14XY+5+0+NSN
3	Carrier Specific number	CSN	14XY+2+CSN
4	Terminating access	0+NSN LN	14XY+3+0+NSN 14XY+3+0+NSN
5.1	Ported carrier specific number	CSN	14XY+42+CSN
5.2	Terminating access ported number	0+NSN LN	14XY+43+0+NSN 14XY+43+0+NSN
6.1	Transit override call	14XY+0+NSN 14XY+0011+CC+NSN 14XY+LN	14XY+9+0+NSN 14XY+9+0011+CC+NSN 14XY+9+0+NSN
6.2 (2)	Transit preselected call	0+NSN 0011+CC+NSN LN	14XY+8+0+NSN 14XY+8+0011+CC+NSN 14XY+8+0+NSN
6.3	Transit call to carrier specific number	CSN	14XY+92+CSN
6.4	Transit call for terminating access	0+NSN LN	14XY+93+0+NSN 14XY+93+0+NSN
6.5.1	Transit call to ported carrier specific number	CSN	14XY+942+CSN
6.5.2	Transit call for ported terminating access	0+NSN LN	14XY+943+0+NSN 14XY+943+0+NSN

**Abbreviations used :**

- CC : Country code typically of the form X,XX or XXX
- NSN : National significant number typically of the form X XXXX XXXX
- LN : Local Number typically of the form XXXX XXXX
- CSN : Carrier specific number typically of the form 1800 X...,041 etc..
- 14XY : Carrier identification code

**Notes :**

- (1) The '+' is included in the table for depiction purposes only. That is, it is not a sent digit. For example the digit string 14XY+0+NSN would be implemented as the following address :14110397654321
- (2) Some networks may implement POI address digits 14XY+95 instead of 14XY+8.