

COMMUNICATIONS  
ALLIANCE LTD



NATIONAL BROADBAND NETWORK  
FIBRE READY DISTRIBUTION NETWORKS

MAY 2010

## **National Broadband Network - Fibre Ready Distribution Networks Industry Guideline**

**Communications Alliance Ltd (formerly Australian Communications Industry Forum Ltd) was formed in 2006 to provide a unified voice for the Australian communications industry and to lead it into the next generation of converging networks, technologies and services.**

### **Disclaimers**

- 1) Notwithstanding anything contained in this Industry Guideline:
  - a) Communications Alliance disclaims responsibility (including where Communications Alliance or any of its officers, employees, agents or contractors has been negligent) for any direct or indirect loss, damage, claim, or liability any person may incur as a result of any:
    - i) reliance on or compliance with this Industry Guideline;
    - ii) inaccuracy or inappropriateness of this Industry Code/Guideline; or
    - iii) inconsistency of this Industry Guideline with any law; and
  - b) Communications Alliance disclaims responsibility (including where Communications Alliance or any of its officers, employees, agents or contractors has been negligent) for ensuring compliance by any person with this Industry Code/Guideline.
- 2) The above disclaimers will not apply to the extent they are inconsistent with any relevant legislation.

### **Copyright**

© Communications Alliance Ltd 2010

This document is copyright and must not be used except as permitted below or under the *Copyright Act 1968*. You may reproduce and publish this document in whole or in part for your or your organisation's own personal or internal compliance, educational or non-commercial purposes. You must not alter or amend this document in any way. You must not reproduce or publish this document for commercial gain without the prior written consent of Communications Alliance. Organisations wishing to reproduce or publish this document for commercial gain (i.e. for distribution to subscribers to an information service) may apply to subscribe to the Communications Alliance Publications Subscription Service by contacting the Communications Alliance Commercial Manager at [info@commsalliance.com.au](mailto:info@commsalliance.com.au). If you publish any part of this document for any purpose, you must also publish this copyright notice as part of that publication.

## TABLE OF CONTENTS

<b>1</b>	<b>INTRODUCTION AND SCOPE</b>	<b>2</b>
1.1	Introduction	2
1.2	Relationship with other Communications Alliance NBN Working Groups	2
1.3	Scope	3
<b>2</b>	<b>ABBREVIATIONS AND DEFINITIONS</b>	<b>5</b>
2.1	List of terms	5
2.2	Abbreviations	5
2.3	Definitions	5
<b>3</b>	<b>GENERAL</b>	<b>7</b>
3.1	Introduction	7
3.2	Dial Before You Dig	7
<b>4</b>	<b>ROUTE SECTIONS</b>	<b>8</b>
4.1	Introduction	8
4.2	Multiple line types	8
4.3	Future Augmentation	8
4.4	Alignment	9
4.5	Robustness	9
4.6	Repairability	9
<b>5</b>	<b>ACCESS POINTS</b>	<b>11</b>
5.1	Introduction	11
5.2	Cable Jointing	11
5.3	Confluence Points	11
5.4	Lead-In Pipe Interface	11
5.5	Network Restoration	12
<b>6</b>	<b>LEAD-IN PIPES</b>	<b>13</b>
6.1	Introduction	13
6.2	Lead In Pipes – Trench and Conduit	13
6.3	Multiple Networks	14
<b>7</b>	<b>REFERENCES</b>	<b>15</b>
	<b>APPENDIX</b>	<b>16</b>
<b>A</b>	<b>CONDUIT CHARACTERISTICS</b>	<b>16</b>

# 1 INTRODUCTION AND SCOPE

## 1.1 Introduction

1.1.1 This document has been developed by the Early Stage Deployments working group of the Communications Alliance National Broadband Network (NBN) Project. It outlines the issues associated with Distribution Networks, and in particular with the physical plant used for the housing of network cables.

1.1.2 This guideline is to be read in conjunction with other relevant codes and guidelines including, but not limited to:

- (a) C524:2004 External Communication Cable Networks; and
- (b) G591:2006 Telecommunications in Road Reserves - Operational Guidelines for Installations.

## 1.2 Relationship with other Communications Alliance NBN Working Groups

1.2.1 The work of the NBN Early Stage Deployments working group is related to activities within other NBN Project working groups in Communications Alliance. The general relationships can be seen in Figure 1.

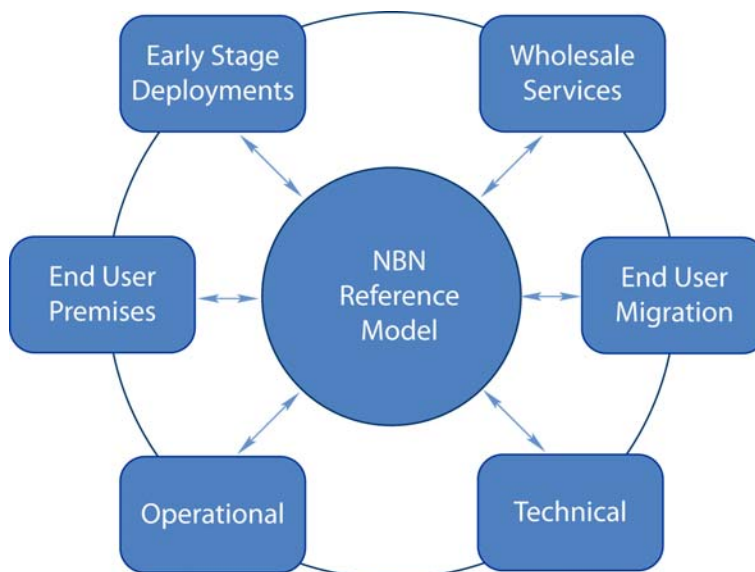

Communications Alliance - NBN Reference Architecture - Release 1 - Jan 2010

**FIGURE 1**

### Communications Alliance NBN Project Working Group Structure

1.2.2 The NBN Early Stage Deployments working group is one of seven working groups established by Communications Alliance to

address industry requirements for the NBN. The other six working groups address the following:

- (c) **NBN Reference Model** - The NBN Reference Model Group is developing a reference model that seeks to identify within the NBN framework:
  - (i) the roles and responsibilities of Service Providers;
  - (ii) key principles related to End Users;
  - (iii) key principles related to Services; and
  - (iv) key principles related to Interconnection of Networks.
- (d) **Wholesale Services** - The Wholesale Services working group is developing high level service definitions relevant to the NBN that will be required in an NBN framework and supplied by NBN Co, FTTP greenfields carriers and other broadband access providers.
- (e) **End User Premises** - The End User Premises working group is developing a set of high level NBN End-User Premises (EUP) installation practices and guidelines.
- (f) **Technical** - The Technical working group is identifying appropriate international standards (or domestic standards and codes if available) and their features which meet the characteristics required by the wholesale services, to demonstrate that the wholesale services can be implemented, and to facilitate the sourcing and configuration of network elements.
- (g) **End User Migration** - The End User Migration working group is defining a 'migration' with respect to the NBN for the definition of processes for customer movement to, within and from the NBN.
- (h) **Operational** - The Operational working group is proposing approaches to enable the best possible customer experience in provisioning, assurance and billing of NBN services.

### 1.3 Scope

- 1.3.1 This document outlines the issues associated with Distribution Networks, and in particular with the physical plant used for the housing of network cables.
- 1.3.2 This document addresses physical distribution cables that are or will be installed in an underground facility.

- 1.3.3 This document addresses underground facilities that are or will be built to suit the requirements for safe and reliable operation of the cable.

*NOTES:*

*1. This document presents a range of scenarios and options that Communications Alliance working groups have identified with the purpose of facilitating broader NBN discussion and decision making for NBNs. It does not represent the preferred position of Communications Alliance, its individual members, or the communications industry.*

*2. While the scenarios presented in this paper are technically feasible, any agreed final set of scenarios will require tradeoffs between technical and operational complexity versus requirements for maximum flexibility in support of functional and service requirements. These issues will need further analyses as part of more detailed Communications Alliance work stream activities.*

## 2 ABBREVIATIONS AND DEFINITIONS

### 2.1 List of terms

A current list of terms and their definitions is available at:  
[https://commswiki.dgit.biz/index.php/Agreed\\_Term\\_Definitions](https://commswiki.dgit.biz/index.php/Agreed_Term_Definitions)

### 2.2 Abbreviations

Abbreviations used in the Guideline and their meaning are:

FOTP Fibre To The Premises

mm millimetres

### 2.3 Definitions

For the purposes of the document:

#### ***Access Point***

means a location that permits physical access for authorised personnel to the components of a Distribution Network.

*NOTE: Examples of Access Points include pits, manholes, fibre enclosures, pillars, fibre distribution hubs, draw boxes.*

#### ***Distribution Conduit***

means conduit connecting major network elements to Access Points such as pits or manholes located near end customer premises.

#### ***Distribution Network***

means a network consisting of:

- (a) Cable and associated joints and equipment that provides the direct connection to individual customer premises;
- (b) Express cable that extends the customer connection to the interface point with the feeder or main part of the network; and
- (c) Conduit and associated pits and equipment that provides the accommodation for the cable and joints.

#### ***Fibre Ready Facility***

has the same meaning as given by section 372HB of the *Telecommunications Act*.

*NOTE: This is included in the draft for comment and is assuming the passage of the Telecommunications Legislation Amendment (Fibre Deployment) Bill 2010 through Federal Parliament to become legislation.*

***Lead-In Pipe***

means pipe linking the distribution pit or manhole closest to the customer's property to the individual premise.

***Route Section***

means a section between Access Points.

*NOTES:*

- 1. An example of a Route Section includes conduit.*
- 2. A Lead-In Pipe is not a Route Section.*

***Starter Pipe***

means a short pipe on the distribution pit or manhole closest to a point inside the boundary of the customer's property (for connection to a Lead-In Pipe).



### 3 GENERAL

#### 3.1 Introduction

3.1.1 The basic constructs of a Distribution Network are:

- (a) Route Sections;
- (b) Access Points; and
- (c) Lead-In Pipes.

3.1.2 Each of the above items has a number of unique considerations, expanded on in the following sections.

3.1.3 Refer to Figure 2 for an illustration of demarcation points between the network constructs.

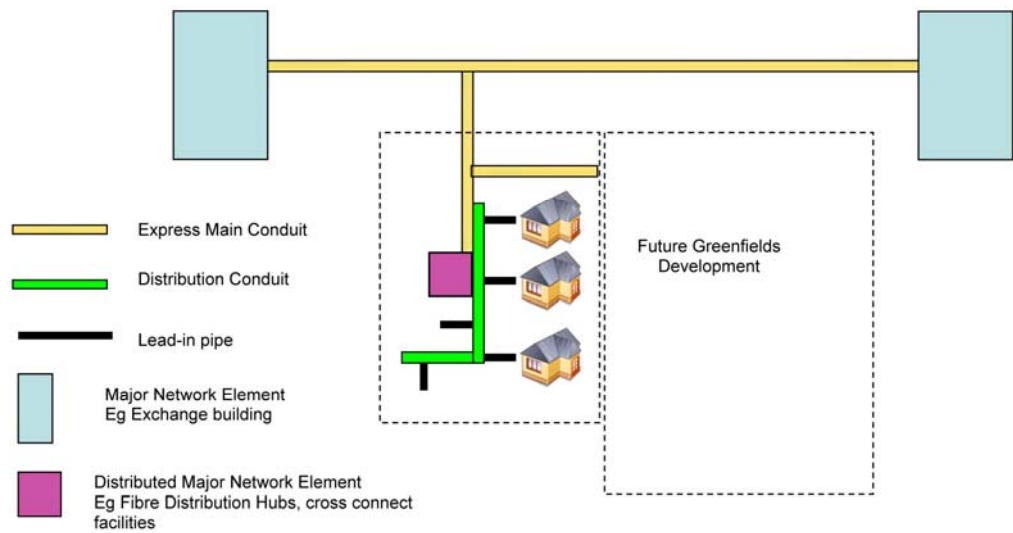

Communications Alliance - Fibre Ready Distribution Networks – Release 1 – May 2010

**FIGURE 2**  
**Network elements**

#### 3.2 Dial Before You Dig

Any new development should register the plans with the Dial Before You Dig service. Dial Before You Dig is a national service designed to prevent damage and disruption to pipe and cable networks. To contact the service phone 1100 or visit the website at <http://www.1100.com.au>.

## 4 ROUTE SECTIONS

### 4.1 Introduction

- 4.1.1 There are three generic construction types for Route Sections. There are:
- (a) Direct buried sheathed cable;
  - (b) Direct buried micro tube cable; and
  - (c) Duct.
- 4.1.2 The choice of construction type will be dependant on the application and the environment in which the plant is to be installed.
- 4.1.3 The main factors to consider are:
- (a) whether the facility will need to support multiple types of cable i.e. fibre and copper cables; and
  - (b) whether there will be a need to augment the cables within that facility at a later point in time.

### 4.2 Multiple line types

- 4.2.1 It is assumed that a single cable sheath will only contain one cable type.
- 4.2.2 It is assumed that a cable tube will only support the installation of a single cable type.
- 4.2.3 If multiple cable types are required, all of the Route Sections listed in section 4.1.1 would support this.
- 4.2.4 If one of the direct buried options in section 4.1.1 is adopted, multiple cables would need to be installed initially.
- 4.2.5 The duct option in section 4.1.1 will support cable sheaths of different cable types installed at different times.

### 4.3 Future Augmentation

- 4.3.1 A sheathed cable is installed with a fixed up front capacity. Should that cable be direct buried, augmentation beyond the cable capacity will require civil construction in order to trench or bore along the cable route. Civil construction is generally high cost, so if the future needs had been perceived, an alternative construction may well have been a better up front solution.
- 4.3.2 Direct buried micro tube cables have a higher degree of flexibility than Direct buried sheathed cables in that they may contain multiple tubes and allow the flexibility to install up front tube capacity in excess of the forecast demand at a very low incremental cost. The main drawbacks for cable tubes are that if

there is slow growth, the tubes may be used inefficiently and the cable will only support a single cable type.

- 4.3.3 Duct is generally installed where there is a perceived requirement or risk that subsequent cables will need to be hauled over the same Route Section at a later point in time. This situation may arise where there is slow growth in an area and it will be uneconomic to install the full capacity up front or where the use of the land is variable and service requirements cannot be forecast with a degree of confidence.
- 4.3.4 In cases where it is envisaged that there will be significant future redevelopment of an area to the extent that public infrastructure such as roads, power and water infrastructure is to be rebuilt, it is not appropriate to install ducts for this eventuality as there will be an opportunity to make the decision on whether or not to install ducts as the infrastructure is rebuilt, often taking advantage of shared trenches with other services.

#### **4.4 Alignment**

- 4.4.1 Telecommunications infrastructure is generally installed within a defined alignment from the property boundary or roadside. Multiple Route Sections installed along a given route must share the alignment, so multiple installations may result in congestion of the alignment and risk to damage to the original infrastructure when subsequent infrastructure is installed.
- 4.4.2 Most greenfields new estates make use of Shared Trenches for services. This complicates the installation of any further conduit after the initial installation because of the close proximity of the communications conduit to other service pipes.

#### **4.5 Robustness**

- 4.5.1 Duct offers the advantage of increased mechanical protection of the cable installation if future excavations for other services are expected.
- 4.5.2 Urban areas also tend to have a higher frequency of disturbance to footpaths and roadways relative to rural areas. Duct is recommended in these areas for the purposes of mechanical protection.

#### **4.6 Repairability**

- 4.6.1 In areas with frequent excavations for other services or service connections the use of duct allows easier replacement of sections of cable that are damaged without the difficulty of associated civil works. This is of particular advantage once an area has been paved as breakout and reinstatement costs can assume a significant proportion of the civil works costs.

- 4.6.2 Refer to section 9.3 of C524 for recommendations on the use of an appropriate marker tape to warn others subsequently excavating a trench.

## **5 ACCESS POINTS**

### **5.1 Introduction**

- 5.1.1 Access Point such as pits and manholes should be installed along Route Sections to enable the cables to be accessed.
- 5.1.2 Above ground Access Points such as pedestal type enclosures are available but may not be preferred by some councils or property developers.
- 5.1.3 Functions performed at Access Points in the Distribution Network include:
  - (a) jointing of cables;
  - (b) forming points of confluence across multiple routes; and
  - (c) interfacing to Lead-In Pipes at customer premises.
- 5.1.4 At any given Access Point, a combination of some or all of the functions in section 5.1.3 may occur.
- 5.1.5 The dimensioning of the Access Point will be determined by the route type, cable type and the function required to be performed at that point.

### **5.2 Cable Jointing**

- 5.2.1 The housing of cable joints and the ability to allow cable jointers to work on those joints can require large pits and manholes.
- 5.2.2 If more than one cable type is present in the route the Access Point must be able to accommodate the cable types.

### **5.3 Confluence Points**

Access Points must be able to accommodate the confluence of conduits from routes that join as well as the jointing of cables that divide and follow multiple paths.

### **5.4 Lead-In Pipe Interface**

- 5.4.1 Access Points must be able to accommodate the interface between street cabling and the Lead-In Pipes to customer premises.
- 5.4.2 A suitable compromise must be made between many Access Points each feeding a small number of Lead-In Pipes, and fewer Access points feeding many Lead-In Pipes.
- 5.4.3 The issues with many Lead-In Pipes from few Access Points are both pit congestion and congestion in the duct sections adjacent to the Access Points.

## 5.5 Network Restoration

- 5.5.1 Access Points form a useful point at which Route Sections may be repaired and jointed should a section of the Route Section become faulty or damaged.
- 5.5.2 While it is not recommended to dimension all Access Points to allow for such network restoration, it is recommended to consider this function where a choice of the dimensioning of the Access Point will allow for this capability.

## 6 LEAD-IN PIPES

### 6.1 Introduction

- 6.1.1 Lead-in Pipes are generally installed during the construction of buildings on the property, which occurs after the construction of the Route Sections and Access Points in the street.
- 6.1.2 The installation of street infrastructure should include the installation of a Starter Pipe from a suitable Access Point in the street to a point approximately 1 metre inside the property boundary.
- 6.1.3 When a resident constructs their premises, a trench will be dug from the side of their premises to the location of a Starter Pipe, and the Lead-In Pipe connected to the Starter Pipe to provide an unbroken conduit through which the lead-in cable can be pulled.
- 6.1.4 Starter Pipes and Lead-In Pipes should each be installed with an appropriate strength draw-cable, and the draw-cables joined securely when the Lead-In Pipes is joined to the Starter Pipe, to enable a cable to be hauled through the pipes.

### 6.2 Lead-In Pipes – Trench and Conduit

- 6.2.1 When a new premise is constructed the various services that are to be reticulated from the street to the building (e.g. water, electricity, telecoms and/or gas) may be installed in one or more shared trenches, or each service may be located in a dedicated trench.
- 6.2.2 Where services are laid in a shared trench, pipes or cables for each service should be installed within the alignments and specifications of a shared trench plan that may be in force in that local area, either through local government or a local utility.
- 6.2.3 Lead-In Pipes should follow a relatively direct path from the property boundary to the location of the building entry point with only gentle bends, and no right-angle bends, to facilitate the later hauling of a cable through the conduit. Bends should be constructed from pre-manufactured curved pipe sections, not from the application of heat to a straight conduit section, to avoid pinching of the internal cable path.
- 6.2.4 Lead-In Pipe paths should conform with the requirements of relevant codes and standards, which includes (but is not limited to):
  - (a) Conduit pipes must conform to the requirements of *AS/ACIF S008 Requirements for Customer Cabling Products*, Section 5.3 Underground Conduit.
  - (b) Conduit and Cables belonging to different telecommunications carriers must maintain a minimum

radial clearance of 100 mm from cables from other carriers, and clearances of up to 300 mm from other forms of utility cables (refer to Table 4 of C524 *External Communications Cable Networks*).

- (c) Telecommunications conduit should not be installed above stormwater drainage pipes (refer to AS/NZS 3500.3 *Plumbing and Drainage – Stormwater drainage*).
- (d) Underground telecommunications cables and conduits on private property must have minimum coverage of 300 mm above the top of the cable or conduit (refer to AS/ACIF S009 *Installation requirements for Customer Cabling (Wiring Rules, Section 18)*). The trench must be dug deep enough to accommodate 300 mm cover plus the diameter of the Lead-In Pipe itself.

- 6.2.5 Lead-In Pipes and Starter Pipes should be no smaller than 23 mm inside diameter for residential dwellings, and 50 mm or 100 mm inside diameter for commercial premises or MDU locations commensurate with the size of the building.

### **6.3 Multiple Networks**

- 6.3.1 If there are multiple networks installed then the connection to the premises might be via either:
  - (a) Sharing of infrastructure among the networks (e.g. one Lead-in Pipe per premise, sharing of pits); or
  - (b) Dedicated infrastructure for each network e.g. (a separate Lead-in Pipe and separate pits for each network).
- 6.3.2 In areas that have been serviced from multiple networks installed along the street, the customer will choose which network they wish to be connected to upon initial service connection. The Lead-In Pipe will then be connected to the Starter Pipe of the respective network, the trench filled and the area often landscaped.
- 6.3.3 If the original tenant or a subsequent tenant decides that they wish to be serviced from the alternative network, then:
  - (a) for the dedicated infrastructure example a new Lead-In Pipe must be constructed, which may require consideration of related factors such as landscaping over the area required for installation.
  - (b) for the shared infrastructure example a new cable may need to replace the existing cable.



## 7 REFERENCES

Publication	Title
<b>Australian Standards</b>	
AS 1345-1995	Identification of the contents of pipes, conduits and ducts <a href="http://infostore.saiglobal.com/store/Details.aspx?ProductID=224345">http://infostore.saiglobal.com/store/Details.aspx?ProductID=224345</a>
AS 3996-2006	Access covers and grates <a href="http://infostore.saiglobal.com/store/Details.aspx?ProductID=307453">http://infostore.saiglobal.com/store/Details.aspx?ProductID=307453</a>
AS/ACIF S008:2006	Requirements for Customer Cabling Products <a href="http://commsalliance.com.au/Documents/Documents/Standards/s008">http://commsalliance.com.au/Documents/Documents/Standards/s008</a>
AS/ACIF S009:2006	Installation requirements for Customer Cabling (Wiring Rules) <a href="http://commsalliance.com.au/Documents/Documents/Standards/s009">http://commsalliance.com.au/Documents/Documents/Standards/s009</a>
AS/NZS 2053	Conduits and fittings for electrical installations <a href="http://infostore.saiglobal.com/store/results2.aspx?searchType=subject&amp;publisher=AS&amp;doctype=All&amp;status=Current&amp;sfld1=ICS%20Code&amp;sval1=29.120.10">http://infostore.saiglobal.com/store/results2.aspx?searchType=subject&amp;publisher=AS&amp;doctype=All&amp;status=Current&amp;sfld1=ICS%20Code&amp;sval1=29.120.10</a>
AS/NZS 3500.3:2003	Plumbing and Drainage – Stormwater drainage <a href="http://infostore.saiglobal.com/store/Details.aspx?ProductID=373023">http://infostore.saiglobal.com/store/Details.aspx?ProductID=373023</a>
AS/NZS 4130:2009	Polyethylene (PE) pipes for pressure applications <a href="http://infostore.saiglobal.com/store/Details.aspx?ProductID=1123080">http://infostore.saiglobal.com/store/Details.aspx?ProductID=1123080</a>
<b>Industry Code</b>	
C524:2004	External Communication Cable Networks <a href="http://commsalliance.com.au/Documents/Documents/codes/c524">http://commsalliance.com.au/Documents/Documents/codes/c524</a>
<b>Industry Guideline</b>	
G591:2006	Telecommunications in Road Reserves - Operational Guidelines for Installations <a href="http://commsalliance.com.au/Documents/Documents/guidelines/g591">http://commsalliance.com.au/Documents/Documents/guidelines/g591</a>

## APPENDIX

### A CONDUIT CHARACTERISTICS

This Appendix includes some suggested characteristics of conduit and related underground components of a Distribution Network.

#### A1 Lead-In Pipe

##### A.1.1 Diameter – Single Dwelling Units

The Lead-In Pipe for a single dwelling unit should facilitate ease of installation of the fibre to the premises.

For example, a 32 mm outside diameter (27 mm internal diameter; refer to AS/NZS 2053) white PVC conduit with draw wire.

##### A.1.2 Diameter – Multi Dwelling Units

The Lead-In Pipe for multi dwelling units should facilitate ease of installation of the fibre to the premises.

Factors to consider in selecting a conduit diameter for multi dwelling units include:

- (a) The number of units i.e. obviously a larger number of units in a development requires a larger conduit.
- (b) The number of Lead-In Pipes e.g. a development may want one or multiple Lead-In Pipes.
- (c) The approach to being Fibre Ready e.g. install fibre up front, or install metallic connections initially with space available to overhaul/replace fibre later.

For example either a 50 mm or 100 mm diameter white PVC conduit with draw wire may be appropriate.

##### A.1.3 Bend radius

Conduit bends on Lead-In Pipe should specify a minimum bend radius.

Factors to consider in choosing a bend radius include:

- (a) The size of the conduit i.e. a larger diameter requires a larger bend radius.
- (b) The number of cables in the conduit.

Current examples of minimum bend radius include 100 mm and 300mm.

##### A.1.4 Pit size

The suggested pit sizes for sites that connect up to four single dwelling units are P4 or P5.

Pit sizes for sites that connect multi dwelling unit will depend on the number of dwellings under construction.

## **A2 Distribution Conduit**

### A.2.1 Diameter

The minimum nominal diameter for the 'last' stage of Distribution Conduit in:

- (a) residential streets should be 50 mm; and
- (b) business parks and road crossings should be 100 mm.

### A.2.2 Trunk conduit diameter

Trunk conduit in a street may have a minimum combination of quantity and diameter of 2 x 50 mm, or 1 x 100 mm.

### A.2.3 Pit size

The suggested minimum pit size for sites that include trunk connections is P6.

Communications Alliance was formed in 2006 to provide a unified voice for the Australian communications industry and to lead it into the next generation of converging networks, technologies and services.

In pursuing its goals, Communications Alliance offers a forum for the industry to make coherent and constructive contributions to policy development and debate.

Communications Alliance seeks to facilitate open, effective and ethical competition between service providers while ensuring efficient, safe operation of networks, the provision of innovative services and the enhancement of consumer outcomes.

It is committed to the achievement of the policy objective of the *Telecommunications Act 1997* - the greatest practicable use of industry self-regulation without imposing undue financial and administrative burdens on industry.



Published by:  
**COMMUNICATIONS  
ALLIANCE LTD**

Level 9  
32 Walker Street  
North Sydney  
NSW 2060 Australia

Correspondence  
PO Box 444  
Milsons Point  
NSW 1565

T 61 2 9959 9111  
F 61 2 9954 6136  
TTY 61 2 9923 1911  
E [info@commsalliance.com.au](mailto:info@commsalliance.com.au)  
[www.commsalliance.com.au](http://www.commsalliance.com.au)  
ABN 56 078 026 507

Care should be taken to ensure the material used is from the current version of the Standard or Industry Code and that it is updated whenever the Standard or Code is amended or revised. The number and date of the Standard or Code should therefore be clearly identified. If in doubt please contact Communications Alliance