

AUSTRALIAN
COMMUNICATIONS
INDUSTRY FORUM



INDUSTRY CODE
ACIF C559:2006
PART 2
SPECTRAL COMPATIBILITY DETERMINATION
PROCESS

**ACIF C559:2006 Unconditioned Local Loop Service (ULLS) Network Deployment
Rules Part 2 Spectral Compatibility Determination Process Industry Code**
First published as ACIF C559:2001
Second edition as ACIF C559:2002
Third edition as ACIF C559:2003
Fourth edition as ACIF C559:2005
Fifth edition as ACIF C559:2006
This Code was released for public comment as DR ACIF C559:2006

Disclaimers

1. Notwithstanding anything contained in this Industry Code:
 - (a) ACIF disclaims responsibility (including where ACIF or any of its officers, employees, agents or contractors has been negligent) for any direct or indirect loss, damage, claim, or liability any person may incur as a result of any:
 - (i) reliance on or compliance with this Industry Code;
 - (ii) inaccuracy or inappropriateness of this Industry Code; or
 - (iii) inconsistency of this Industry Code with any law; and
 - (b) ACIF disclaims responsibility (including where ACIF or any of its officers, employees, agents or contractors has been negligent) for ensuring compliance by any person with this Industry Code.
2. The above disclaimers will not apply to the extent they are inconsistent with any relevant legislation.

Copyright

© Australian Communications Industry Forum Limited 2006

This document is copyright and must not be used except as permitted below or under the *Copyright Act 1968*. You may reproduce and publish this document in whole or in part for your or your organisation's own personal or internal compliance, educational or non-commercial purposes. You must not alter or amend this document in any way. You must not reproduce or publish this document for commercial gain without the prior written consent of ACIF. Organisations wishing to reproduce or publish this document for commercial gain (i.e. for distribution to subscribers to an information service) may apply to subscribe to the *ACIF Publications Subscription Service* by contacting the ACIF Business Manager at acif@acif.org.au. If you publish any part of this document for any purpose, you must also publish this copyright notice as part of that publication.

TABLE OF CONTENTS

| | | |
|----------|--|-----------|
| 1 | INTRODUCTION AND OVERVIEW | 2 |
| | 1.1 Introduction | 2 |
| | 1.2 Overview | 2 |
| 2 | ACIF SPECTRAL COMPATIBILITY DETERMINATION PROCESS | 4 |
| | 2.1 Definition of ACIF Spectral Compatibility Determination Process | 4 |
| | 2.2 Definition of Spectral Compatibility Benchmark and Basis System | 4 |
| | 2.3 Unacceptable Interference into a Basis System | 5 |
| | 2.4 Unacceptable Excess Power | 10 |
| 3 | PROCESS FOR ASSESSMENT OF NON-DEPLOYMENT CLASS SYSTEMS | 13 |
| 4 | PROCESS FOR DETERMINATION OF SPECTRAL COMPATIBILITY BENCHMARKS FOR BASIS SYSTEMS AND DEPLOYMENT RULES FOR DEPLOYMENT CLASS SYSTEMS. | 15 |
| | 4.1 Spectral Compatibility Benchmark I Determination | 15 |
| | 4.2 Spectral Compatibility Benchmark II Determination | 21 |
| 5 | CALCULATION OF BASIS SYSTEM PERFORMANCE | 27 |
| | 5.1 Cable Environment | 27 |
| | 5.2 The Noise Environment | 28 |
| | 5.3 Transceiver Models for Basis Systems | 30 |
| 6 | EXPECTED WORST CASE WIDEBAND NOISE MASK ON THE ULLS | 35 |
| 7 | REFERENCES | 38 |
| | APPENDIX A TRANSMIT PSD TEMPLATES FOR DEPLOYMENT CLASS SYSTEMS | 39 |

1 INTRODUCTION AND OVERVIEW

1.1 Introduction

Part 2 describes the ACIF Spectral Compatibility Determination Process together with the assumptions and analytical techniques required to assess system spectral compatibility.

The ACIF Spectral Compatibility Determination Process is the process that determines matters pertaining to spectral compatibility of Disturbing and Disturbed Systems used on distinct unconditioned Communications Wires. Elements of the process include determining the Spectral Compatibility Benchmarks of Basis Systems, Unacceptable Interference into a Basis System, and Unacceptable Excess Power.

Part 1 of this Code requires that carriers and carriage service providers that propose to deploy a system that is not within a Deployment Class use the ACIF Spectral Compatibility Determination Process to determine whether or not the proposed system causes either Unacceptable Interference into a Basis System or Unacceptable Excess Power. A computer model based on this process has been developed by Telstra and is available to affected parties.

The Spectral Compatibility Benchmarks for Basis Systems are set out in Clauses 4.1.1 and 4.2.1 of Part 2 of this Code, Unacceptable Interference into a Basis System is addressed in Clause 2.3 of Part 2 of this Code, and Unacceptable Excess Power is addressed in Clause 2.4 of Part 2 of this Code.

1.2 Overview

It is well known that in the unshielded twisted pair cable used to provide local loops, xDSL signals on one twisted pair cause interference to signals on other twisted pairs in the same cable. This interference, called crosstalk, is caused by electromagnetic coupling between the unshielded twisted pairs and has the potential to unacceptably degrade the performance of services/systems sharing the same cable, thereby compromising network integrity.

In an unbundled loop environment, where an Access Provider's local loop cable is being shared by other carriers and carriage service providers (i.e. Access Seekers who are being supplied with the ULLS) inter-system crosstalk must be controlled to ensure an acceptable level of protection of network integrity. Therefore, in order to ensure effective exploitation of the unbundled local loop, there is a requirement for Access Seekers and Access Providers to abide by a set of agreed performance requirements by suitable selection of the type, quantity and disposition of xDSL systems to ensure their spectral compatibility.

Crosstalk depends on pair-to-pair exposure, signal frequency and signal strength.

Pair-to-pair exposure depends on the length variation of proximity of pairs in a cable and crosstalk coupling increases with increasing proximity and cable length. Unavoidable variability in cable manufacturing processes leads to unavoidable variability in exposure between cable pairs and it is impossible to specify/predict the exact amount of crosstalk between pairs in a cable. In addition, the level of

interference is increased by any imbalance in the equipment and this is controlled by appropriate specification of equipment longitudinal balance similar to the intrinsic cable pair longitudinal balance.

Crosstalk coupling is very sensitive to exposure and the variability/unpredictability of crosstalk interference dominates all other system variability, and an extreme worst-case design cannot be economically justified.

This leads to the unavoidable use of statistical measures and techniques to determine performance requirements for the operation of systems that use the ULLS. The statistical techniques are based on the underlying assumption that the Access Provider makes available to the Access Seeker cable pairs chosen at random from a population of cable pairs that exhibit no unusual or 'faulty' performance. In other words, it is assumed that cable pairs exhibit typical transmission and crosstalk performance variability consistent with typical cable manufacturing and installation processes. As mentioned above, an extreme worst case design which ensures that all such typical pairs can be used for Unconditioned Local Loop Service cannot be economically justified, and so the performance requirements for operation of systems using the ULLS are based on assuming that less than 1% of typical pairs offered to an Access Seeker exhibit excessive crosstalk.

With the expectation that less than 1% of offered pairs prove unsuitable, there is little benefit in requiring any pre-qualification of offered pairs. Rather, offered pairs need only be tested when excessive crosstalk is suspected.

High frequency energy has higher coupling than lower frequency energy because crosstalk increases with frequency. Thus the higher the speed/capacity of the xDSL system, the greater the potential for inter-system interference. Crosstalk is directly proportional to signal strength, so limiting transmit power lessens inter-service interference. Hence, controlling the spectral content and balance of xDSL signals through specifying transmit signal spectral masks and equipment longitudinal balance, and controlling the number and disposition of xDSL systems in a cable are effective means of limiting crosstalk interference between systems.

2 ACIF SPECTRAL COMPATIBILITY DETERMINATION PROCESS

2.1 Definition of ACIF Spectral Compatibility Determination Process

The **ACIF Spectral Compatibility Determination Process** is the process that determines matters pertaining to spectral compatibility of Disturbing and Disturbed Systems used on the ULLS. Elements of the process include the determination of Unacceptable Interference into a Basis System, the determination of Unacceptable Excess Power, and the process for determination of Spectral Compatibility Benchmarks for Basis Systems and Deployment Rules for Deployment Class Systems.

2.2 Definition of Spectral Compatibility Benchmark and Basis System

A **Spectral Compatibility Benchmark** is the determined relationship between system bit rates achievable by a Basis System in each direction and system deployment range (expressed as a single deployment range for a fixed rate system) for a system error rate of 10^{-7} with margin of 6dB in the 1% worst-case crosstalk environment.

NOTE 1: The 1% worst case-crosstalk environment is defined in Clause 5.2 of Part 2 of this Code.

NOTE 2: The Spectral Compatibility Benchmark includes the rates in each direction of transmission. For a fixed rate system, the Spectral Compatibility Benchmark is the system range which achieves the required rate in both directions with at least 6 dB margin.

A **Basis System** is a system type that has one or more determined Spectral Compatibility Benchmarks.

The Basis Systems used in this Code are set out in Table 2-1 of Part 2 of this Code and their Spectral Compatibility Benchmarks are given in Clauses 4.1.1 and 4.2.1 of Part 2 of this Code.

NOTE 1: Both transmitter and receiver performance of a Basis System are required to determine its Spectral Compatibility Benchmark.

NOTE 2: Some, but not all, Legacy Systems are Basis Systems.

NOTE 3: Basis Systems and the associated Spectral Compatibility Benchmarks for different network topologies provide the basis for ensuring network integrity.

NOTE 4: Deployment Classes are defined in Part 3, including those for Basis Systems. Refer to Table A-1 in Part 3 of this Code for the list of Deployment Classes.

| Name | Description | Relevant Standard |
|--|------------------------------|-----------------------|
| Voiceband | | |
| ISDN-BR | 2B1Q | ITU-T G.961 |
| E1-HDB3 | 2048 kbit/s | ITU-T G.703 |
| ADSL | Reduced NEXT option | ITU-T G.992.1 |
| ADSL2+ | Non-overlapped spectrum mode | ITU-T G.992.5 |
| SHDSL 576kbit/s | 16-TCPAM, $f_{sym}=194.67$ | ITU-T G.991.2 |
| SHDSL 1160 kbit/s | 16-TCPAM, $f_{sym}=389.33$ | ITU-T G.991.2 |
| SHDSL 2312 kbit/s | 16-TCPAM, $f_{sym}=773.33$ | ITU-T G.991.2 |
| ESHDSL 3840 kbit/s | 16-TCPAM, $f_{sym}=1282.67$ | ITU-T G.991.2 Annex F |
| ESHDSL 5696 kbit/s (Note 1) | 32-TCPAM, $f_{sym}=1426$ | ITU-T G.991.2 Annex F |
| Removed while revising ACIF C559:2003 HDSL-784 HDSL-1168 HDSL-2320 ADSL-Lite | | |

TABLE 2-1:

Basis Systems

NOTE 1: Only 4 bits/symbol (32-TCPAM) available at this data rate in ITU-T Recommendation G991.2.

Transceiver models for the Basis Systems are given in Clause 5.3 of Part 2 of this Code.

2.3 Unacceptable Interference into a Basis System

Unacceptable Interference into a Basis System is defined in Clause 8.2.2 of Part 1 of this Code. The concept of Unacceptable Interference into a Basis System requires determination of the impact on Basis Systems of crosstalk interference caused by disturbing systems. The impact on Basis Systems is determined as follows:

1. The determination of crosstalk interference is based on a representative cable sub-unit consisting of 10 twisted pairs, 4 of which carry the disturbing system type and 5 of which carry the disturbed system type. Hence each disturbed system is subject to interference from 4 systems of the disturbing type and 4 of the same type as itself.
2. The method of calculation of the 1% worst-case crosstalk from the disturbing systems is given in Clause 5 of Part 2 of this Code.
3. The transmit and receive characteristics of the Basis Systems are given in Clause 5.3 of Part 2 of this Code.

4. The topologies considered in the determination must include all those permissible within the deployment restrictions for the disturbing system.
5. The level of interference depends on the relative disposition of disturbing and disturbed systems, and in particular, to represent system performance differences between Deployment State A and Deployment State B, two Spectral Compatibility Benchmarks are defined for each Spectrally Asymmetric Basis System. Spectral Compatibility Benchmark I applies to Basis Systems fed from the Highest NRP in Deployment State A and from the Nominated Lower NRP in Deployment State B, whilst Spectral Compatibility Benchmark II applies to Basis Systems fed from the Highest NRP in Deployment State B.

2.3.1 Test for Crosstalk Interference

For all configurations listed below, the performance of all Basis System types as defined in Clause 5.3 of Part 2 of this Code must be no worse than the applicable Spectral Compatibility Benchmarks of those Basis Systems as given in Clauses 4.1.1 and 4.2.1 of Part 2 of this Code.

The spectral compatibility calculations specified in this clause are based on the assumptions of Clause 2.3 of Part 2 of this Code and the method of calculation of Basis System performance given in Clause 5 of Part 2 of this Code with the following configurations of the proposed system interfering into each Basis System type in turn.

NOTE 1: Different configurations are required for each direction of the Spectral Compatibility Benchmark I;

NOTE 2: In each direction the Spectral Compatibility Benchmark is a function of the range of the disturbed Basis System from its Deployment Reference Point (usually at the Highest NRP).

The process for determining proposed deployment rules based on the requirement of Unacceptable Interference into a Basis System is given in Clause 3 of Part 2 of this Code for Non-Deployment Class Systems and in Clause 4 of Part 2 of this Code for Deployment Class Systems.

- (a) Spectral Compatibility Benchmark I configuration.

The configurations in Figures 2-1 and 2-2 of Part 2 of this Code for determination of the downstream Spectral Compatibility Benchmark I consist of 4 interferers of the proposed type fed from the proposed Lowest Asymmetric System Feed Point and with the customer end at the higher (or shorter range from the highest NRP) of:

 - (i) the same location as the disturbed Basis System, or
 - (ii) a point at the proposed Deployment Limit below the Deployment Reference Point.

and 4 interferers of the same type and the same Deployment Class Group A PSD as the Basis System, with both ends colocated with the disturbed Basis System,

interfering into the Basis System fed from the Highest NRP.

The configuration in Figure 2-3 for determination of the upstream Spectral Compatibility Benchmark I consists of 4 interferers of the proposed type and 4 interferers of the same type and the same Deployment Class Group A PSD, as the disturbed Basis System, both with ends colocated with the disturbed Basis System, interfering into the Basis System fed from the Highest NRP.

In both of these configurations the performance must be equal to or better than the corresponding Spectral Compatibility Benchmark I in Clause 4.1.1 of Part 2 of this Code for the relevant direction.

- (b) Spectral Compatibility Benchmark II configuration (Deployment State B - only for Spectrally Asymmetric Basis Systems)

Spectral Compatibility Benchmark II is defined only for the downstream direction and only for Basis System range beyond the specified range to the Nominated Lower NRP.

The configuration in Figure 2-4 of Part 2 of this Code for determination of the downstream Spectral Compatibility Benchmark I consists of 4 interferers of the proposed type fed from the proposed Lowest Asymmetric System Feed Point and with the customer end at the higher of:

- (i) the same location as the disturbed Basis System, or
- (ii) a point at the proposed Deployment Limit below the Deployment Reference Point.

and 4 interferers of the same type and same Deployment Class Group A PSD as the Basis System fed from the Nominated Lower NRP, interfering into the Basis System fed from the Highest NRP. This should be repeated for 0.5 km intervals between 0.5 km and 3 km of the range from the Highest NRP to the Nominated Lower NRP.

In this configuration the performance must be equal to or better than the corresponding Spectral Compatibility Benchmarks II in Clause 4.2.1 of Part 2 of this Code with the specified range parameter.

NOTE: Lowest Asymmetric System Feed Point is the point nominated as per Clause 8.4.4(6) in Part 1 of this Code.

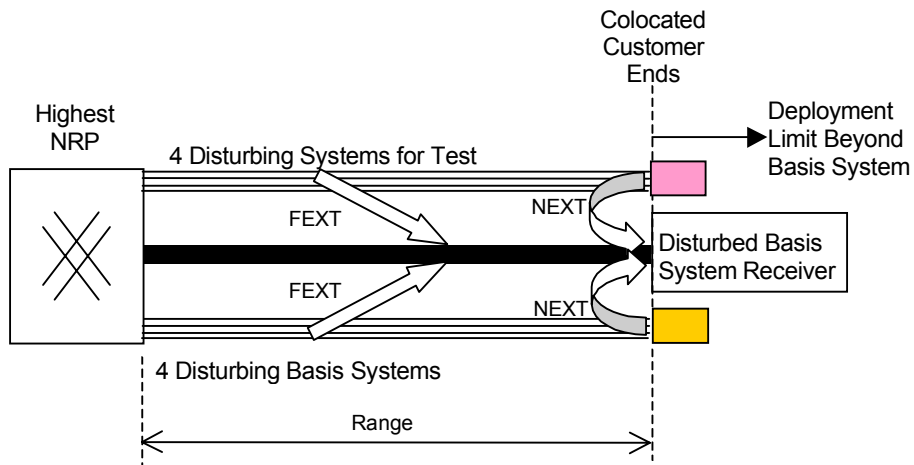

FIGURE 2-1

Configuration for Downstream Benchmark I for Basis System ranges up to the proposed Deployment Limit

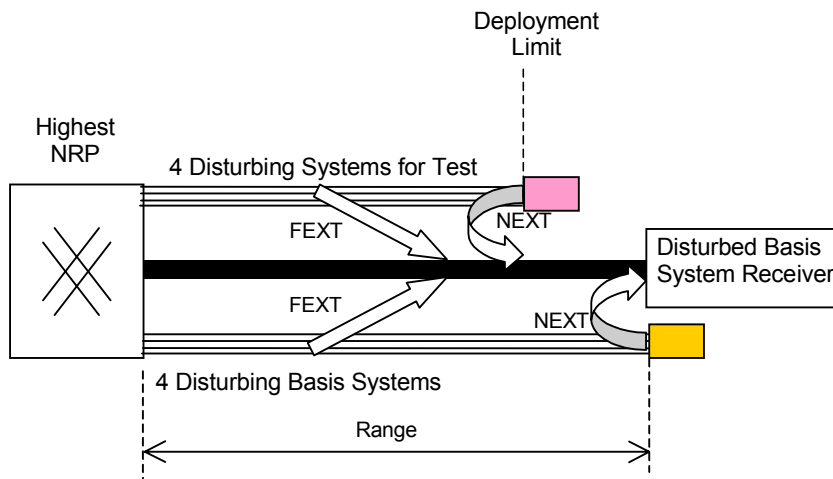

FIGURE 2-2

Configuration for Downstream Benchmark I for Basis System ranges beyond the proposed Deployment Limit

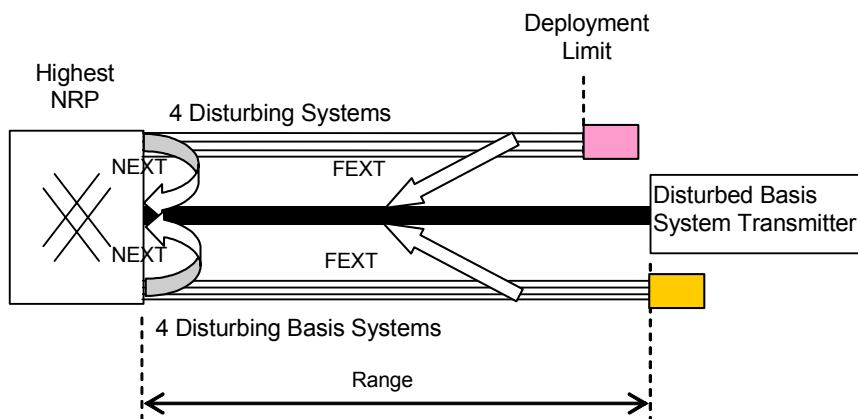

FIGURE 2-3

Configuration for Upstream Benchmark I

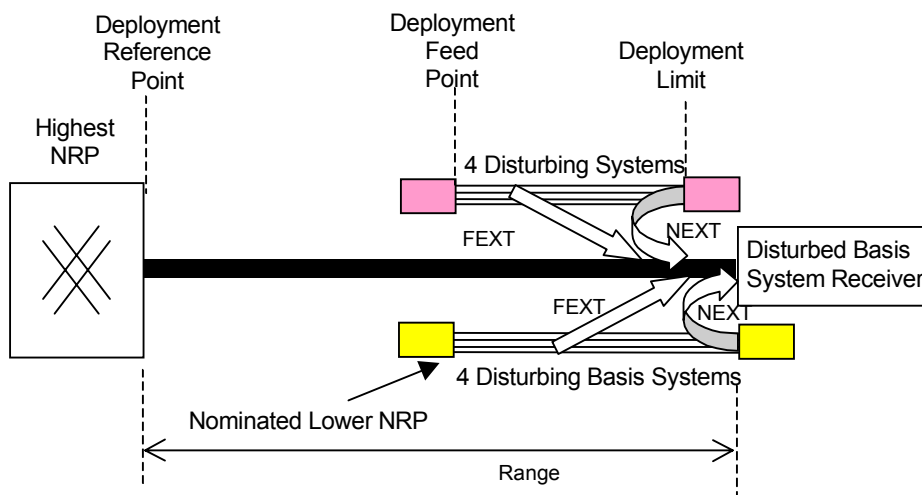

FIGURE 2-4

Configuration for Benchmark II (Downstream only) for Asymmetric Basis Systems.

NOTE 1: The Deployment Reference Point and Lowest Asymmetric Feed Point may be nominated by the AS; the Deployment Limit shown is based on the limit for Deployment State A and is measured from the proposed Deployment Reference Point.

NOTE 2: This diagram only shows the case in Clause 2.3.1 (b) (ii) of Part 2 of this Code.

2.3.2 Tests for Longitudinal Balance and Signal Levels

For Non-Deployment Class Systems, the longitudinal output voltage masks of Clause 8.4.4(7) of Part 1 of this Code and the longitudinal balance masks specified of Clause 8.4.4(8) of Part 1 of this Code are required to be within the limits below at all frequencies in the specified frequency ranges.

(a) Longitudinal output voltage limit:
-50dBV in any 4kHz band over a frequency range of 10kHz to 12040kHz

(b) Longitudinal balance limit:
40dB from 20kHz to f kHz with a slope 20dB/decade below 20kHz and -20dB/decade above f.

The value of f is the highest frequency in kHz at which the PSD mask is 20dB below its peak .

Where the system uses a different PSD in each direction, the frequency of the upper breakpoint for longitudinal balance is the same for both ends of the system and is the maximum determined from either end PSD.

For Deployment Class Systems, the longitudinal output voltage and balance masks are referenced in Part 3 of this Code.

2.4 Unacceptable Excess Power

Clause 8.2.1 of Part 1 of this Code requires a Non Deployment Class System not to cause **Unacceptable Excess Power**. Excess power is a measure of the amount by which the system transmit PSD exceeds the maximum PSD of all Deployment Class Systems in Part 3 of this code, as shown in Clause 2.4.1 of this Code.

2.4.1 Define the Unacceptable Excess Power Template $U(f)$ as the maximum over all of the transmit PSD templates in mW/Hz of all Deployment Class Systems.

$$U(f) = \text{Max} \{P_i(f)\}$$

where $P_i(f)$ are the transmit PSD templates (Group A requirements) of the Deployment Class systems in both directions.

The function $10 \log_{10}(U(f))$ in dBm/Hz is given in Table 2-2 of Part 2 of this Code and plotted in Figure 2-5 of Part 2 of this Code.

Define the function:

$$POS(X) = \begin{cases} X, & X \geq 0 \\ 0, & X < 0 \end{cases}$$

For a proposed system with transmit PSD $S(f)$ mW/Hz, the excess power is given by:

$$\text{Excess power} = \int_0^{\infty} POS(S(f) - U(f))df$$

2.4.2 The system does not cause Unacceptable Excess Power if Excess power ≤ 0.05 mW.

| Centre Freq, KHz | Limiting Technology | | UEP $10\log_{10}\{U(f)\}$ | Centre Freq, KHz | Limiting Technology | | UEP $10\log_{10}\{U(f)\}$ |
|---------------------|---------------------|---------------|------------------------------|------------------------|------------------------|---------|------------------------------|
| | | | | | | | |
| 5 | Class 9x | SHDSL, type 1 | -30.7 | 1250 | Class 6h | ADSL 2+ | -43.2 |
| 50 | Class 4a | Basic ISDN | -35.6 | 1300 | Class 6h | ADSL 2+ | -44.3 |
| 100 | Class 6g | READSL | -36.4 | 1350 | Class 6h | ADSL 2+ | -45.3 |
| 150 | Class 6c | ADSL/ISDN | -38.0 | 1400 | Class 6h | ADSL 2+ | -46.2 |
| 200 | Class 6c | ADSL/ISDN | -38.0 | 1450 | Class 6h | ADSL 2+ | -47.1 |
| 250 | Class 6g | READSL | -37.6 | 1500 | Class 6h | ADSL 2+ | -47.9 |
| 300 | Class 6g | READSL | -37.0 | 1550 | Class 6h | ADSL 2+ | -48.8 |
| 350 | Class 6g | READSL | -37.0 | 1600 | Class 6h | ADSL 2+ | -49.7 |
| 400 | Class 6g | READSL | -37.0 | 1650 | Class 6h | ADSL 2+ | -50.1 |
| 450 | Class 6g | READSL | -37.0 | 1700 | Class 6h | ADSL 2+ | -50.2 |
| 500 | Class 6g | READSL | -37.0 | 1750 | Class 6h | ADSL 2+ | -50.3 |
| 550 | Class 6g | READSL | -37.0 | 1800 | Class 6h | ADSL 2+ | -50.4 |
| 600 | Class 6 a | ADSL FD | -40.0 | 1850 | Class 6h | ADSL 2+ | -50.5 |
| 650 | Class 6 a | ADSL FD | -40.0 | 1900 | Class 6h | ADSL 2+ | -50.7 |
| 700 | Class 6 a | ADSL FD | -40.0 | 1950 | Class 6h | ADSL 2+ | -50.8 |
| 750 | Class 6 a | ADSL FD | -40.0 | 2000 | Class 6h | ADSL 2+ | -50.9 |
| 800 | Class 6 a | ADSL FD | -40.0 | 2050 | Class 6h | ADSL 2+ | -51.0 |
| 850 | Class 6 a | ADSL FD | -40.0 | 2100 | Class 6h | ADSL 2+ | -51.1 |
| 900 | Class 6 a | ADSL FD | -40.0 | 2150 | Class 6h | ADSL 2+ | -51.2 |
| 950 | Class 6 a | ADSL FD | -40.0 | 2200 | Class 6h | ADSL 2+ | -51.3 |
| 1000 | Class 6 a | ADSL FD | -40.0 | 2250 | Class 6h | ADSL 2+ | -57.1 |
| 1050 | Class 6 a | ADSL FD | -40.0 | 2500 | | | -62.9 |
| 1100 | Class 6 a | ADSL FD | -40.0 | 3000 | | | -62.9 |
| 1150 | Class 6h | ADSL 2+ | -41.0 | 3093 | | | -93.5 |
| 1200 | Class 6h | ADSL 2+ | -42.2 | 12000 | | | -93.5 |

TABLE 2.2

Unacceptable Excess Power Template

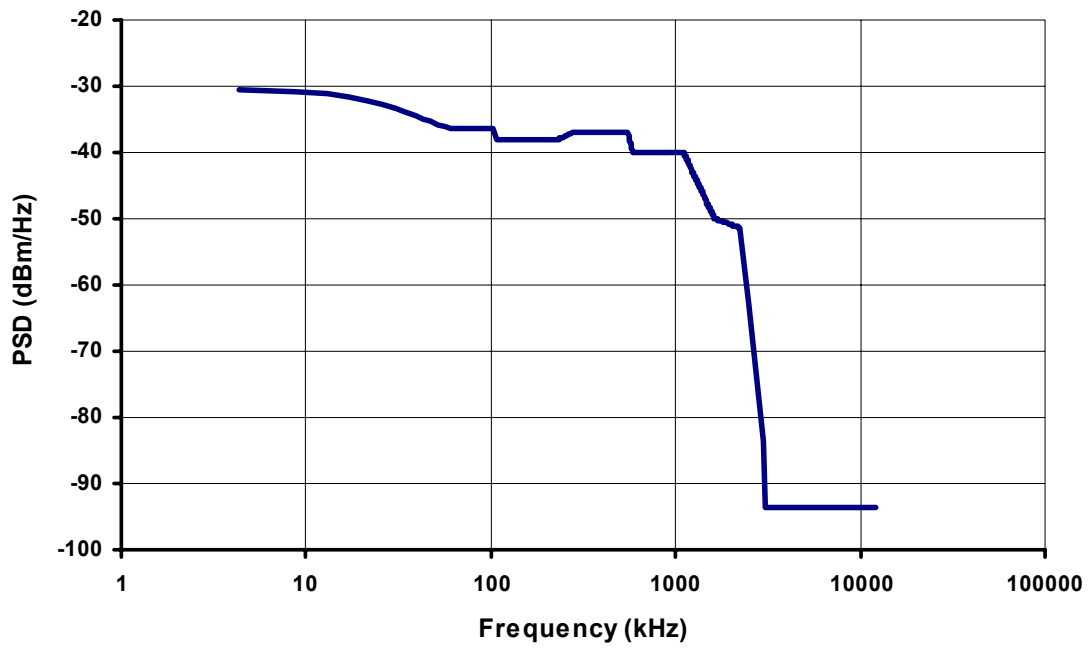

FIGURE 2-5

Unacceptable Excess Power Template

3 PROCESS FOR ASSESSMENT OF NON-DEPLOYMENT CLASS SYSTEMS

All systems operated using the ULLS must not cause Unacceptable Interference into a Basis System. Clause 8.4 of Part 1 of this Code requires a carrier or carriage service provider proposing to operate a Non-Deployment Class system to use the ACIF Spectral Compatibility Determination Process described below to determine whether the system will cause Unacceptable Interference into a Basis System.

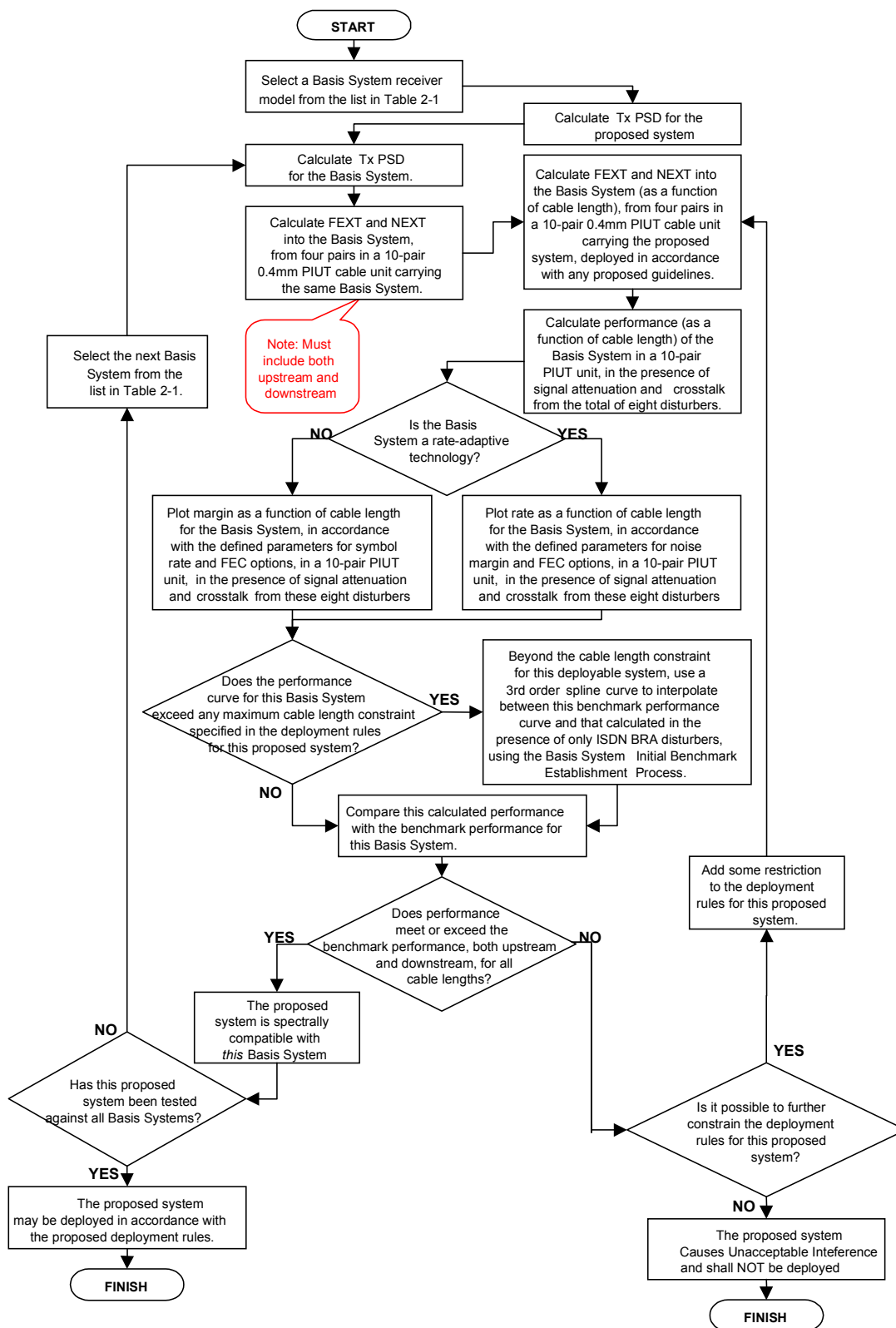

FIGURE 3-1

Process for Assessment of Non-Deployment Class Systems

NOTE: If the proposed Deployment Class System has a minimum cable length constraint then calculations for shorter lengths than the Deployment Limit are not required

4 PROCESS FOR DETERMINATION OF SPECTRAL COMPATIBILITY BENCHMARKS FOR BASIS SYSTEMS AND DEPLOYMENT RULES FOR DEPLOYMENT CLASS SYSTEMS.

The Spectral Compatibility Benchmarks have been determined for a set of idealised Basis Systems that are representative of the system types used on the ULLS. The Spectral Compatibility Benchmarks provide a metric against which the interference generated by proposed deployments is assessed. The crosstalk from 4 systems from a Deployment Class, together with 4 systems of the same type as the Basis System, must not degrade the performance of the Basis System below its Spectral Compatibility Benchmark.

NOTE: The 4 systems from a Deployment Class referred to above may be the same as the Basis System.

A consistent set of Deployment Classes and Spectral Compatibility Benchmarks is achieved by taking into account the trade-off between suitable Deployment Rules for each Deployment Class and realistic Spectral Compatibility Benchmarks.

Because this Code defines two Deployment States A and B for a DA, two Spectral Compatibility Benchmarks and multiple configurations must be considered in determining whether the operation of a system will cause Unacceptable Interference into a Basis System. These configurations are given in Clause 2.3.1 of Part 2 of this Code.

Spectral Compatibility Benchmark I is used to determine the Deployment Rules in Deployment State A.

In Deployment State B, any of the above derived State A Deployment Limits apply, but the Deployment Reference Point from which each limit is measured may differ. For Basis Systems deployed from the Nominated Lower NRP in Deployment State B, the Spectral Compatibility Benchmark I performance is used. However for Basis Systems deployed from any higher NRP in Deployment State B, the Spectral Compatibility Benchmark is degraded by an amount dependent on the range from that higher NRP to the Nominated Lower NRP. Spectral Compatibility Benchmark II gives that performance with the range as a parameter.

4.1 Spectral Compatibility Benchmark I Determination

This process and the resulting Spectral Compatibility Benchmark I applies to Basis Systems originating from the Highest NRP when the DA is in Deployment State A, and to Basis Systems originating from the Nominated Lower NRP when the DA is in Deployment State B. In these situations the Basis Systems achieve their best possible Spectral Compatibility Benchmark in the presence of other systems. (Note that in Deployment State B, a Spectrally Asymmetric Basis System deployed from the Highest NRP will suffer degraded performance compared with Spectral Compatibility Benchmark I; an additional Spectral Compatibility Benchmark II for these cases is included in Clause 4.2 of Part 2 of this Code.)

The process for determining whether or not a system is deployable is shown in Figure 4-1 of Part 2 of this Code and the process for reviewing the Spectral Compatibility Benchmark I of a Basis System is shown in Figure 4-2 and Figure 4-3 of Part 2 of this Code.

Analysis techniques, assumptions and transceiver models for Basis Systems are shown in Clause 5 of Part 2 of this Code.

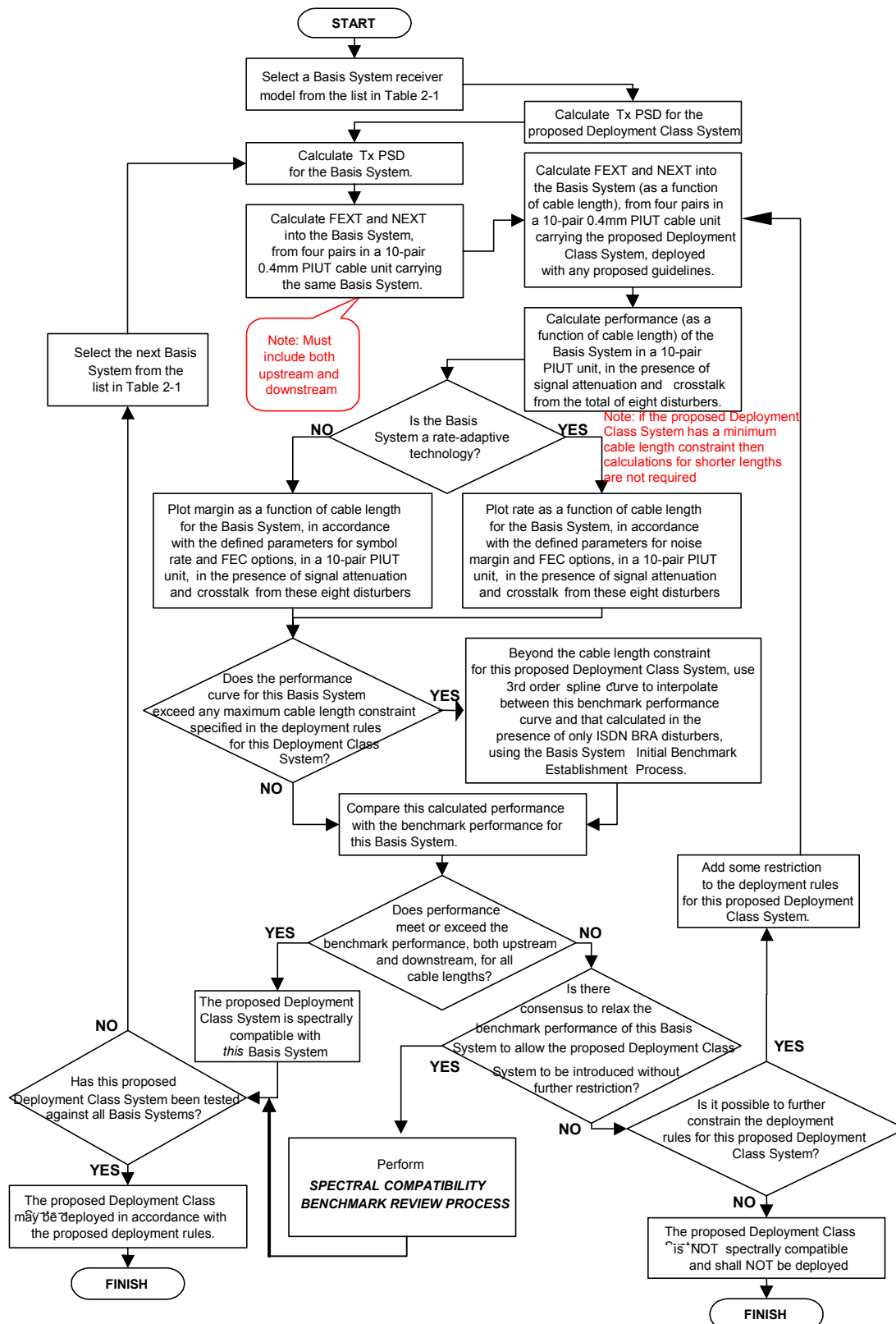

FIGURE 4-1

Deployment Class System Deployment Rule Determination

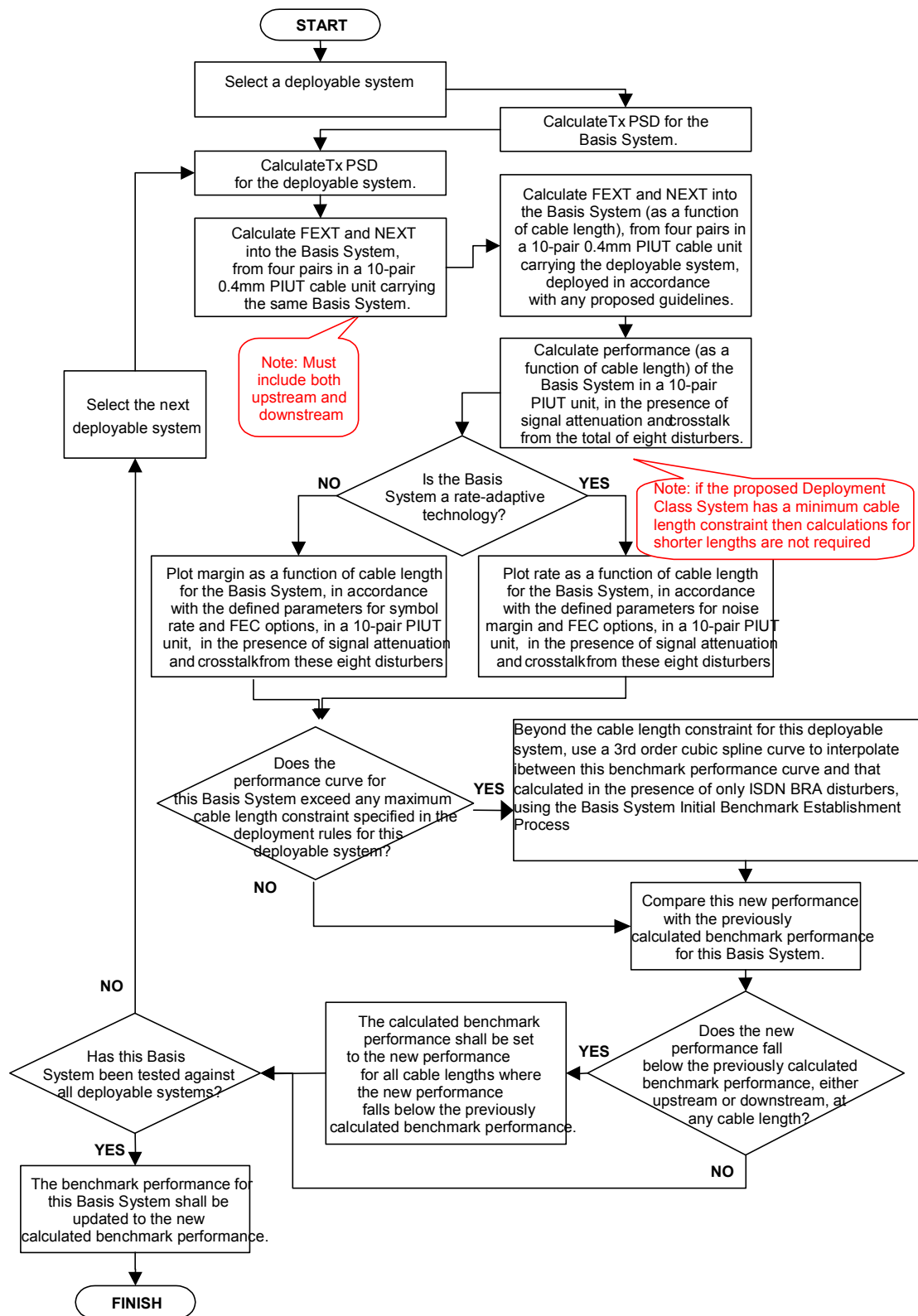

FIGURE 4-2

Spectral Compatibility Benchmark Review

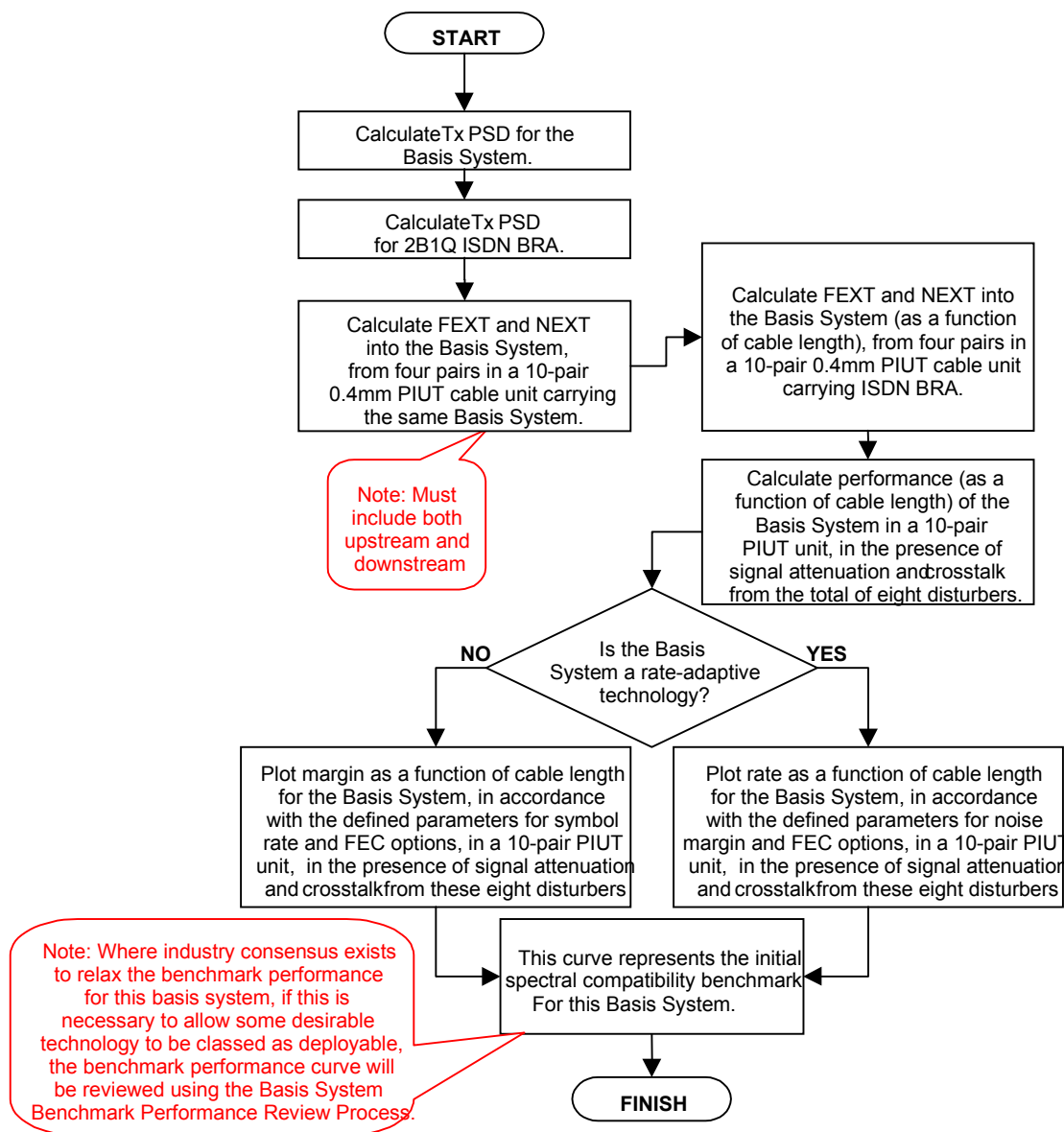

FIGURE 4-3

Initial Spectral Compatibility Benchmark Establishment

4.1.1 Spectral Compatibility Benchmark I

Spectral Compatibility Benchmarks I have been determined for the Basis Systems described in Clause 5.3 of Part 2 of this Code.

The Spectral Compatibility Benchmark I for the Voiceband Basis System is the requirement that the total power of any disturbing system in the frequency band $0 < f \leq 4\text{kHz}$ shall be less than -10dBm (600Ω).

The Spectral Compatibility Benchmarks I for the fixed rate Basis Systems are given in Table 4-1 of Part 2 of this Code both as ranges and as attenuations at the relevant reference frequency (half of the baud rate) in each case.

| System | Range (km of 0.4mm PIUT) | Reference frequencye (kHz) | Indicative Attenuation (dB at Reference Frequency) |
|--------------------------|---|---|---|
| ISDN-BR | 5.51 | 40 | 45.45 |
| E1-HDB3 | 1.00 | 1024 | 26.20 |
| SHDSL 576(C-16) kbit/s | 3.65 | 96 | 36.3 |
| SHDSL 1160(C-16) kbit/s | 2.65 | 196 | 31.4 |
| SHDSL 2312(C-16) kbit/s | 1.71 | 388 | 26.5 |
| ESHDSL 3840(C-16) kbit/s | 1.05 | 649 | 26.5 |
| ESHDSL 5696(C-32) kbit/s | 0.62 | 713 | 13.0 |

TABLE 4-1

**Spectral Compatibility Benchmark I for Fixed Rate Systems,
operating on 0.4mm PIUT cable**

NOTE: For SHDSL/ESHDSL data rates, the suffix (C-16) or (C-32) refers to different line encodings – see Appendix J of Part 3 of this Code for details on SHDSL and Appendix K of Part 3 of this Code for details on ESHDSL.

The Spectral Compatibility Benchmarks I of the variable rate systems are given in Table 4-2 of Part 2 of this Code and in Figure 4-4 of Part 2 of this Code as the net payload rate with 6 dB margin versus attenuation at 300 kHz. Note that these Spectral Compatibility Benchmarks have been determined for transceivers operating on well-matched and well-balanced lines; i.e. with no impact from splitters.

| | | ADSL | | ADSL2+ | | | | ADSL | | ADSL2+ | |
|-------|-----------|---------------|------|---------------|------|-------|-----------|---------------|-----|---------------|-----|
| Range | Atten(dB) | Rate (kbit/s) | | Rate (kbit/s) | | Range | Atten(dB) | Rate (kbit/s) | | Rate (kbit/s) | |
| (km) | at300kHz | down | up | down | up | (km) | at300kHz | down | up | down | up |
| 0.1 | 1.38 | 6648 | 1000 | 13400 | 1100 | 2.6 | 35.91 | 4777 | 575 | 5916 | 615 |
| 0.2 | 2.76 | 6648 | 1000 | 13400 | 1100 | 2.7 | 37.29 | 4579 | 544 | 5605 | 584 |
| 0.3 | 4.14 | 6648 | 1000 | 13400 | 1100 | 2.8 | 38.67 | 4377 | 513 | 5309 | 553 |
| 0.4 | 5.52 | 6648 | 1000 | 13400 | 1100 | 2.9 | 40.05 | 4179 | 484 | 5025 | 524 |
| 0.5 | 6.91 | 6648 | 1000 | 13400 | 1100 | 3 | 41.43 | 3984 | 460 | 4749 | 498 |
| 0.6 | 8.29 | 6648 | 1000 | 13400 | 1100 | 3.1 | 42.81 | 3776 | 439 | 4476 | 475 |
| 0.7 | 9.67 | 6648 | 1000 | 13400 | 1100 | 3.2 | 44.19 | 3539 | 421 | 4178 | 455 |
| 0.8 | 11.05 | 6648 | 1000 | 13400 | 1100 | 3.3 | 45.57 | 3298 | 404 | 3893 | 436 |
| 0.9 | 12.43 | 6396 | 1000 | 13400 | 1100 | 3.4 | 46.95 | 3052 | 388 | 3621 | 418 |
| 1 | 13.81 | 6010 | 1000 | 13251 | 1096 | 3.5 | 48.34 | 2797 | 369 | 3360 | 399 |
| 1.1 | 15.19 | 5605 | 1000 | 12685 | 1067 | 3.6 | 49.72 | 2534 | 337 | 3111 | 377 |
| 1.2 | 16.57 | 5402 | 998 | 12320 | 1038 | 3.7 | 51.10 | 2277 | 306 | 2859 | 346 |
| 1.3 | 17.95 | 5392 | 969 | 12116 | 1009 | 3.8 | 52.48 | 2022 | 275 | 2560 | 315 |
| 1.4 | 19.33 | 5397 | 939 | 11860 | 979 | 3.9 | 53.86 | 1769 | 244 | 2267 | 284 |
| 1.5 | 20.72 | 5358 | 910 | 11460 | 950 | 4 | 55.24 | 1523 | 211 | 1989 | 253 |
| 1.6 | 22.10 | 5298 | 880 | 10861 | 920 | 4.1 | 56.62 | 1283 | 153 | 1726 | 221 |
| 1.7 | 23.48 | 5294 | 850 | 10113 | 890 | 4.2 | 58.00 | 1064 | 101 | 1477 | 190 |
| 1.8 | 24.86 | 5341 | 820 | 9472 | 860 | 4.3 | 59.38 | 860 | 50 | 1244 | 159 |
| 1.9 | 26.24 | 5307 | 790 | 8782 | 830 | 4.4 | 60.76 | 663 | 4 | 1027 | 128 |
| 2 | 27.62 | 5266 | 759 | 8265 | 799 | 4.5 | 62.15 | 423 | 0 | 827 | 96 |
| 2.1 | 29.00 | 5242 | 729 | 7832 | 769 | 4.6 | 63.53 | 289 | 0 | 644 | 41 |
| 2.2 | 30.38 | 5227 | 698 | 7469 | 738 | 4.7 | 64.91 | 123 | 0 | 473 | 5 |
| 2.3 | 31.76 | 5213 | 667 | 6934 | 707 | 4.8 | 66.29 | 0 | 0 | 315 | 0 |
| 2.4 | 33.14 | 5157 | 637 | 6562 | 677 | 4.9 | 67.67 | 0 | 0 | 177 | 0 |
| 2.5 | 34.53 | 4984 | 606 | 6230 | 646 | 5 | 69.05 | 0 | 0 | 51 | 0 |

TABLE 4-2

Spectral Compatibility Benchmark I values for Variable Rate Systems, operating on 0.4mm PIUT cable.

NOTE: At short ranges the actual calculated net transmission rates exhibit step fluctuations caused by the mandatory power cut-back provisions for ADSL and ADSL2/ADSL2+ systems, specified in Table C-2 of Part 3 of this Code. These fluctuations have been removed by setting constant rates (equal to the lowest local minima) across this region of the table for ADSL.

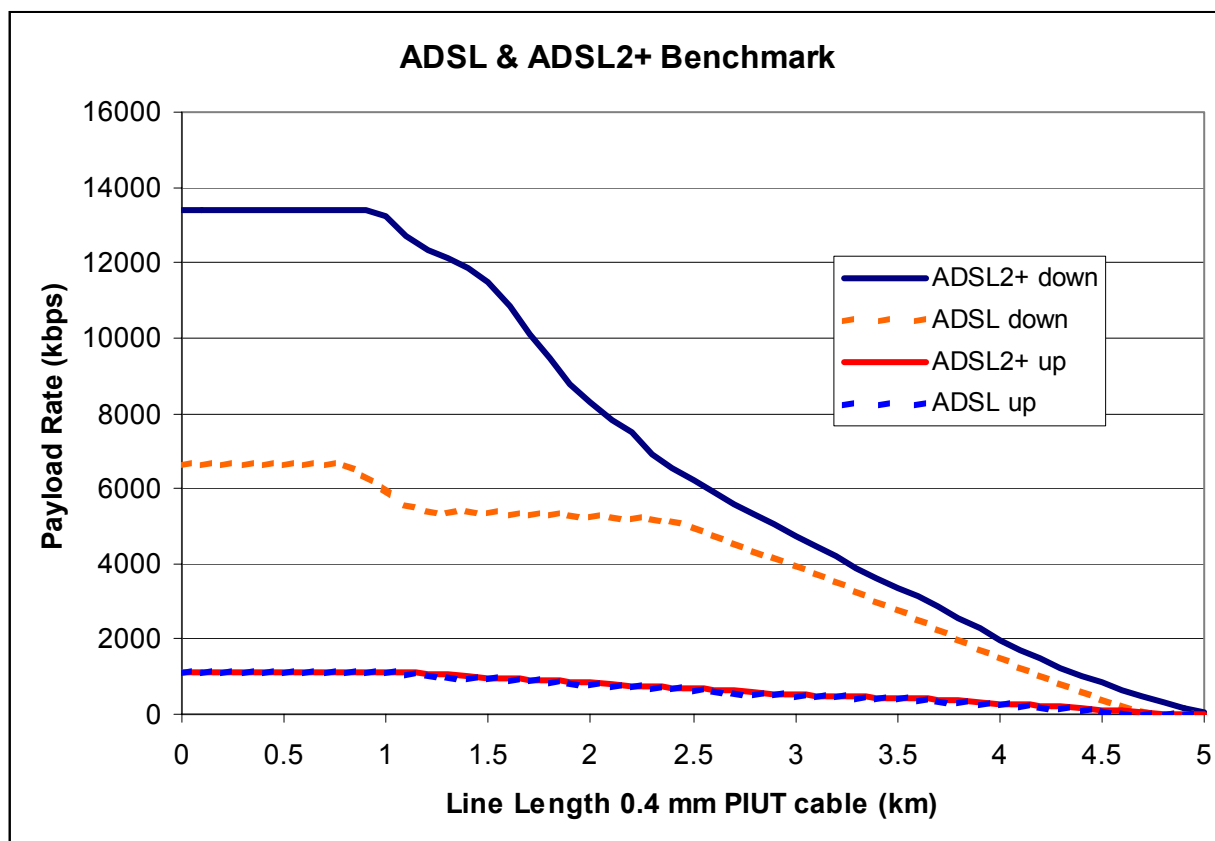

FIGURE 4-4

Spectral Compatibility Benchmark I values for Variable Rate Systems, operating on 0.4mm PIUT cable

4.2 Spectral Compatibility Benchmark II Determination

Spectral Compatibility Benchmark II applies to Spectrally Asymmetric Basis Systems originating from any NRP higher than the Nominated Lower NRP when the DA is in Deployment State B. Those Basis systems unavoidably suffer degraded performance as a result of unequal level FEXT from other Spectrally Asymmetric systems which may be deployed from lower NRPs in Deployment State B. These Spectral Compatibility Benchmarks II have been generated in order to determine which systems may be deployed from the Nominated Lower NRP in Deployment State B, without further degrading the performance of Spectrally Asymmetric Basis Systems originating from the Highest NRP. Because the use of symmetric systems from the Highest NRP does not result in failure to achieve the Spectral Compatibility Benchmarks I performance of those systems, these Spectral Compatibility Benchmarks II apply only to Spectrally Asymmetric Basis Systems.

The process of determination of the Spectral Compatibility Benchmark II uses the processes in Figs 4-1 to 4-3 with the following modifications:

- (a) Only the performance of Spectrally Asymmetric Basis Systems operating from the Highest NRP in Deployment State B are considered.
- (b) A separate Spectral Compatibility Benchmark II performance is established for each of a range of lengths on 0.4mm PIUT

cable from the Highest NRP to the Nominated Lower NRP at which the disturbing systems are fed.

- (c) The process of establishing the Spectral Compatibility Benchmark II curves must not result in any change to the Deployment Limits, but may result in a change in the location of the Lowest Asymmetric Feed Point and the Deployment Reference Point for some Deployment Classes in Deployment State B.

4.2.1 Spectral Compatibility Benchmark II

The Spectral Compatibility Benchmarks II of the Spectrally Asymmetric Basis Systems when fed from the Highest NRP in Deployment State B are given in Figure 4-5 and Table 4-3 of Part 2 of this Code for ADSL and Figure 4-6 and Table 4-4 of Part 2 of this Code for ADSL2+. In each case the Spectral Compatibility Benchmark II is a function of the range from the Highest NRP to the Nominated Lower NRP for Deployment State B.

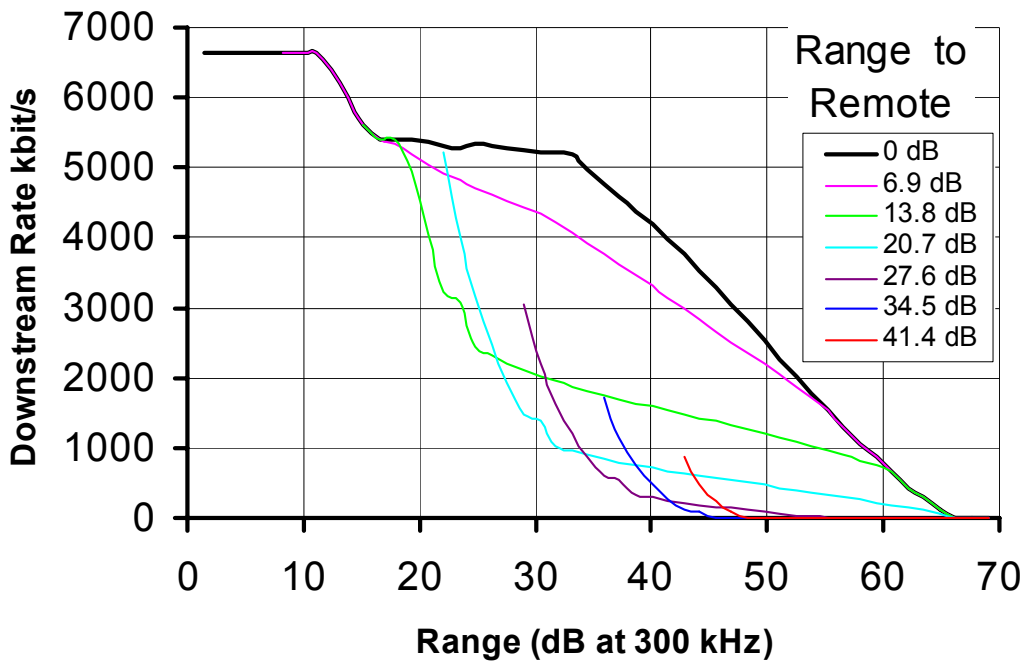

FIGURE 4-5

Spectral Compatibility Benchmark II values for ADSL as a function of range from the Highest NRP, with range from the Highest NRP to the Nominated Lower NRP as a parameter.

| Range | | Attenuation at 300 kHz to remote feed (Dist on 0.4 PIUT | | | | | | |
|-----------|---------------|---|-----------------|------------------|-----------------|------------------|------------------|------------------|
| km .4PIUT | dB at 300 kHz | 0 dB | 6.9 dB (0.5 km) | 13.8 dB (1.0 km) | 20.7 dB (1.5km) | 27.6 dB (2.0 km) | 34.5 dB (2.5 km) | 41.4 dB (3.0 km) |
| 0.10 | 1.38 | 6648 | | | | | | |
| 0.20 | 2.76 | 6648 | | | | | | |
| 0.30 | 4.14 | 6648 | | | | | | |
| 0.40 | 5.52 | 6648 | | | | | | |
| 0.50 | 6.9 | 6648 | | | | | | |
| 0.60 | 8.28 | 6648 | 6648 | | | | | |
| 0.70 | 9.66 | 6648 | 6648 | | | | | |
| 0.80 | 11.04 | 6648 | 6648 | | | | | |
| 0.90 | 12.42 | 6396 | 6396 | | | | | |
| 1.00 | 13.8 | 6011 | 6011 | | | | | |
| 1.10 | 15.18 | 5605 | 5605 | 5605 | | | | |
| 1.20 | 16.56 | 5403 | 5403 | 5403 | | | | |
| 1.30 | 17.94 | 5392 | 5331 | 5392 | | | | |
| 1.40 | 19.32 | 5398 | 5184 | 4961 | | | | |
| 1.50 | 20.7 | 5358 | 5052 | 4037 | | | | |
| 1.60 | 22.08 | 5299 | 4931 | 3240 | 5218 | | | |
| 1.70 | 23.46 | 5294 | 4819 | 3066 | 4014 | | | |
| 1.80 | 24.84 | 5341 | 4715 | 2432 | 3157 | | | |
| 1.90 | 26.22 | 5307 | 4618 | 2313 | 2485 | | | |
| 2.00 | 27.6 | 5266 | 4524 | 2213 | 1932 | | | |
| 2.10 | 28.98 | 5243 | 4434 | 2114 | 1482 | 3051 | | |
| 2.20 | 30.36 | 5228 | 4346 | 2029 | 1375 | 2202 | | |
| 2.30 | 31.74 | 5214 | 4225 | 1957 | 1024 | 1636 | | |
| 2.40 | 33.12 | 5193 | 4081 | 1882 | 953 | 1209 | | |
| 2.50 | 34.5 | 4968 | 3937 | 1818 | 896 | 872 | | |
| 2.60 | 35.88 | 4777 | 3784 | 1757 | 843 | 598 | 1720 | |
| 2.70 | 37.26 | 4579 | 3629 | 1698 | 794 | 531 | 1135 | |
| 2.80 | 38.64 | 4377 | 3472 | 1641 | 755 | 329 | 764 | |
| 2.90 | 40.02 | 4179 | 3312 | 1585 | 710 | 288 | 490 | |

| | | | | | | | | |
|------|-------|------|------|------|-----|-----|-----|-----|
| 3.00 | 41.4 | 3984 | 3151 | 1538 | 675 | 250 | 284 | |
| 3.10 | 42.78 | 3777 | 2987 | 1484 | 632 | 221 | 124 | 869 |
| 3.20 | 44.16 | 3540 | 2830 | 1430 | 599 | 195 | 85 | 477 |
| 3.30 | 45.54 | 3299 | 2664 | 1384 | 567 | 162 | 0 | 244 |
| 3.40 | 46.92 | 3053 | 2504 | 1330 | 535 | 137 | 0 | 82 |
| 3.50 | 48.3 | 2797 | 2344 | 1276 | 502 | 121 | 0 | 0 |
| 3.60 | 49.68 | 2535 | 2191 | 1220 | 470 | 98 | 0 | 0 |
| 3.70 | 51.06 | 2277 | 2038 | 1156 | 430 | 75 | 0 | 0 |
| 3.80 | 52.44 | 2022 | 1877 | 1099 | 391 | 45 | 0 | 0 |
| 3.90 | 53.82 | 1770 | 1718 | 1034 | 361 | 16 | 0 | 0 |
| 4.00 | 55.20 | 1524 | 1524 | 968 | 324 | 0 | 0 | 0 |
| 4.10 | 56.58 | 1283 | 1283 | 894 | 295 | 0 | 0 | 0 |
| 4.20 | 57.96 | 1064 | 1064 | 818 | 259 | 0 | 0 | 0 |
| 4.30 | 59.34 | 860 | 860 | 742 | 216 | 0 | 0 | 0 |
| 4.40 | 60.72 | 664 | 664 | 664 | 181 | 0 | 0 | 0 |
| 4.50 | 62.10 | 423 | 423 | 423 | 147 | 0 | 0 | 0 |
| 4.60 | 63.48 | 290 | 290 | 290 | 114 | 0 | 0 | 0 |
| 4.70 | 64.86 | 123 | 123 | 123 | 73 | 0 | 0 | 0 |
| 4.80 | 66.24 | 0 | 0 | 0 | 0 | 0 | 0 | 0 |

TABLE 4-3

Spectral Compatibility Benchmark II values for ADSL in kbit/s as a function of range from the Highest NRP, with range from the Highest NRP to the Nominated Lower NRP as a parameter.

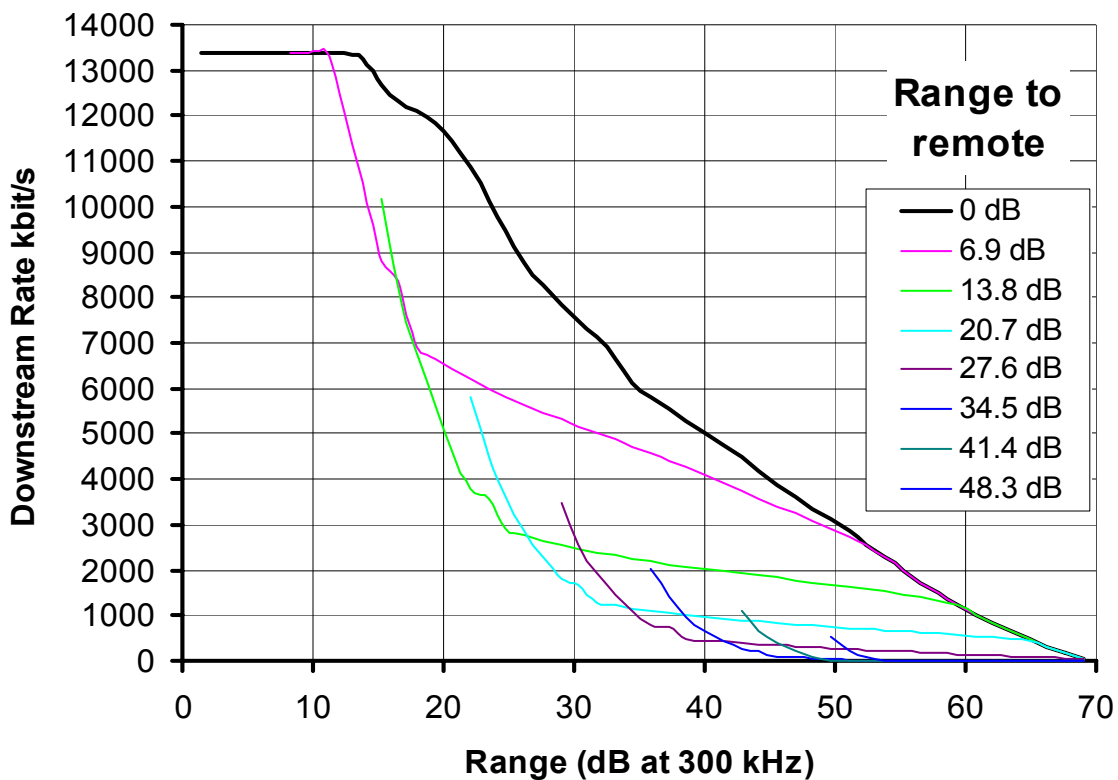

FIGURE 4-6

Spectral Compatibility Benchmark II values for ADSL2+ as a function of range from the Highest NRP, with range from the Highest NRP to the Nominated Lower NRP as a parameter.

| Range | | Attenuation at 300 kHz to remote feed (Dist on 0.4 PIUT wire) | | | | | | | |
|------------|---------------|---|--------------------|---------------------|---------------------|---------------------|---------------------|---------------------|---------------------|
| km .4 PIUT | dB at 300 kHz | 0 dB | 6.9 dB (0.5 km) | 13.8 dB (1.0 km) | 20.7 dB (1.5 km) | 27.6 dB (2.0 km) | 34.5 dB (2.5 km) | 41.4 dB (3.0 km) | 48.3 dB (3.5 km) |
| 0.1 | 1.38 | 13400 | | | | | | | |
| 0.2 | 2.76 | 13400 | | | | | | | |
| 0.3 | 4.14 | 13400 | | | | | | | |
| 0.4 | 5.52 | 13400 | | | | | | | |
| 0.5 | 6.9 | 13400 | | | | | | | |
| 0.6 | 8.28 | 13400 | 13400 | | | | | | |
| 0.7 | 9.66 | 13400 | 13400 | | | | | | |
| 0.8 | 11.04 | 13400 | 13400 | | | | | | |
| 0.9 | 12.42 | 13400 | 12088 | | | | | | |
| 1.0 | 13.8 | 13251 | 10522 | | | | | | |
| 1.1 | 15.18 | 12685 | 8794 | 10188 | | | | | |
| 1.2 | 16.56 | 12321 | 8380 | 8218 | | | | | |
| 1.3 | 17.94 | 12116 | 6929 | 6786 | | | | | |
| 1.4 | 19.32 | 11861 | 6653 | 5614 | | | | | |
| 1.5 | 20.7 | 11460 | 6411 | 4619 | | | | | |
| 1.6 | 22.08 | 10862 | 6197 | 3766 | 5790 | | | | |
| 1.7 | 23.46 | 10114 | 6000 | 3575 | 4508 | | | | |
| 1.8 | 24.84 | 9473 | 5818 | 2891 | 3599 | | | | |
| 1.9 | 26.22 | 8783 | 5647 | 2762 | 2875 | | | | |
| 2.0 | 27.6 | 8266 | 5480 | 2651 | 2283 | | | | |
| 2.1 | 28.98 | 7833 | 5321 | 2555 | 1789 | 3464 | | | |
| 2.2 | 30.36 | 7469 | 5167 | 2464 | 1679 | 2550 | | | |
| 2.3 | 31.74 | 7127 | 5016 | 2384 | 1295 | 1938 | | | |
| 2.4 | 33.12 | 6663 | 4867 | 2314 | 1223 | 1472 | | | |
| 2.5 | 34.5 | 6122 | 4719 | 2245 | 1162 | 1102 | | | |
| 2.6 | 35.88 | 5824 | 4570 | 2184 | 1104 | 799 | 2038 | | |
| 2.7 | 37.26 | 5542 | 4419 | 2126 | 1055 | 735 | 1393 | | |
| 2.8 | 38.64 | 5273 | 4266 | 2072 | 1013 | 502 | 981 | | |
| 2.9 | 40.02 | 5014 | 4103 | 2020 | 971 | 460 | 680 | | |
| 3.0 | 41.4 | 4750 | 3928 | 1970 | 932 | 426 | 445 | | |
| 3.1 | 42.78 | 4476 | 3752 | 1921 | 898 | 392 | 260 | 1120 | |
| 3.2 | 44.16 | 4179 | 3578 | 1874 | 867 | 365 | 221 | 678 | |
| 3.3 | 45.54 | 3893 | 3408 | 1827 | 833 | 336 | 87 | 407 | |
| 3.4 | 46.92 | 3622 | 3237 | 1781 | 804 | 313 | 68 | 216 | |
| 3.5 | 48.3 | 3360 | 3067 | 1735 | 777 | 291 | 45 | 77 | |
| 3.6 | 49.68 | 3111 | 2901 | 1683 | 750 | 271 | 27 | 0 | 532 |
| 3.7 | 51.06 | 2859 | 2735 | 1631 | 724 | 251 | 11 | 0 | 237 |
| 3.8 | 52.44 | 2561 | 2561 | 1577 | 699 | 232 | 0 | 0 | 71 |
| 3.9 | 53.82 | 2267 | 2267 | 1521 | 674 | 214 | 0 | 0 | 0 |
| 4.0 | 55.2 | 1990 | 1990 | 1462 | 649 | 201 | 0 | 0 | 0 |
| 4.1 | 56.58 | 1726 | 1726 | 1396 | 624 | 183 | 0 | 0 | 0 |
| 4.2 | 57.96 | 1477 | 1477 | 1328 | 599 | 166 | 0 | 0 | 0 |
| 4.3 | 59.34 | 1244 | 1244 | 1244 | 573 | 149 | 0 | 0 | 0 |
| 4.4 | 60.72 | 1028 | 1028 | 1028 | 547 | 136 | 0 | 0 | 0 |
| 4.5 | 62.1 | 828 | 828 | 828 | 521 | 119 | 0 | 0 | 0 |
| 4.6 | 63.48 | 644 | 644 | 644 | 494 | 102 | 0 | 0 | 0 |
| 4.7 | 64.86 | 473 | 473 | 473 | 458 | 85 | 0 | 0 | 0 |
| 4.8 | 66.24 | 316 | 316 | 316 | 316 | 69 | 0 | 0 | 0 |
| 4.9 | 67.62 | 178 | 178 | 178 | 178 | 54 | 0 | 0 | 0 |
| 5.0 | 69 | 51 | 51 | 51 | 51 | 38 | 0 | 0 | 0 |

TABLE 4-4

Spectral Compatibility Benchmark II values for ADSL2+ in kbit/s as a function of range from the Highest NRP, with range from the Highest NRP to the Nominated Lower NRP as a parameter.

5 CALCULATION OF BASIS SYSTEM PERFORMANCE

For a given disturbing system type, the Basis System performance is calculated for each of the configurations in Clause 2.3.1 of Part 2 of this Code using the cable attenuation models and parameters of Clause 5.1 of Part 2 of this Code, the crosstalk noise environment of Clause 5.2 and the Basis System transceiver models of Clause 5.3 of Part 2 of this Code. This calculation is implemented in a software tool which is available to Carriers and Carriage Service Providers.

Basis System performance is the achievable rate versus range (or just the range for a fixed rate system) for that Basis System when the 1% worst case error rate equals 10^{-7} with a 6dB margin.

5.1 Cable Environment

The multiplicity of cable types and gauges found in the Australian customer access network, and indeed in any one customer loop, cannot all be modelled separately. To simplify matters, the most common type of Communications Wire, viz., 0.4mm Paper Insulated Unit Twin (PIUT) copper pair cable, is taken to be representative of the behaviour of customer access loops.

The fundamental parameters of this cable are (for f in kHz):

$$R = \left(r_0^4 + r_1 f^2 \right)^{\frac{1}{4}} \quad \Omega / km \quad \text{where}$$

$$r_0 = 2.71793 \times 10^2; \quad r_1 = 1.24169 \times 10^5 \quad (1)$$

$$L = \frac{l_0 + l_1 \left(\frac{f}{f_m} \right)^\beta}{1 + \left(\frac{f}{f_m} \right)^\beta} \quad mH / km \quad \text{where}$$

$$l_0 = 6.43631 \times 10^{-1}; \quad l_1 = 4.28481 \times 10^{-1}; \quad f_m = 1.17408 \times 10^3; \quad \beta = 8.67987 \times 10^{-1} \quad (2)$$

$$G = g_0 f^\alpha \quad S / km \quad \text{where}$$

$$\text{where } g_0 = 1.01848 \times 10^{-6}; \quad \alpha = 1.24621 \quad (3)$$

$$C = c_0 + c_1 f^{-\chi} \quad mF / km \quad \text{where}$$

$$c_0 = 3.46262 \times 10^{-5}; \quad c_1 = 1.08788 \times 10^{-5}; \quad \chi = 3.89154 \times 10^{-2} \quad (4)$$

Studies of system spectral compatibility are performed as if the whole access network were made up of 0.4mm PIUT. The resulting deployment range limits for deployable systems are then converted, at a suitable frequency for the system under study, to Calculated Attenuation Deployment Limits for application to mixed cable types and gauges.

The layout and make-up of the access network has a significant influence on spectral compatibility in that pairs serving customers that are widely separated geographically have a low probability of being in the same cable unit. This leads to the assumption in the study of zero

probability of pairs being in the same unit for customers separated by more than 1.2 km.

5.2 The Noise Environment

The types of noise considered in the analysis include:

- (a) Background white Gaussian noise at a PSD of -140 dBm/Hz (assumed the same and added into all cases – as per T1E1.4)
- (b) Self crosstalk noise from other systems of the same type as the Disturbed System; and
- (c) Compatibility crosstalk noise from transmission systems of different type from the Disturbed System.

5.2.1 Crosstalk Noise

The crosstalk noise at the input to the disturbed receiver may be via NEXT and/or FEXT paths from other pairs in the same cable.

The NEXT or FEXT path is modelled using the 1% worst case (or 99th percentile) of the power sum crosstalk noise from n disturbers. For Australian cables with 10-pair subunits (other cables may have different unit size but still give approximately the same worst case noise for the same % of disturber fill in the unit), the worst case power sum crosstalk formulas are:

NEXT Power Sum Attenuation (NEXTPSA) is the ratio in dB of one of the n identical disturbing PSDs to the total NEXT noise from those disturbers at the NEAR end of the disturbed pair.

$$NEXTPSA = 40.5 - 6 \log\left(\frac{n}{4}\right) - 15 \log(f) \quad (5)$$

FEXT Power Sum Ratio (FEXTPSR) is the ratio in dB of the far end received PSD of the n identical disturbing systems to the total FEXT noise from those disturbers at the FAR end of the disturbed pair.

$$FEXTPSR = 36 - 6 \log\left(\frac{n}{4}\right) - 10 \log(f^2 l) \quad (6)$$

where n is the number of disturbers from a 10-pair subunit, l is the length of 0.4mm PIUT cable in km, and f is in MHz.

NEXTPSA is known to remain about the same for all gauges of access network cables, due to the compensating effects of pair separation and cable attenuation. Hence it is assumed to be the same for all cables, including mixed gauge cables.

The variation of FEXT with cable gauge is less well understood, but FEXTPSR is known to increase (i.e. FEXT noise decreases for the same length) significantly with increasing gauge of the cable. However, the $-10 \log(l)$ dependence on length results in a corresponding decrease in FEXTPSR for a heavier gauge cable run with the same attenuation. Hence FEXTPSR is assumed to be the same for all cables, including mixed gauge cables, with the same attenuation.

Category 5 cable may be used in buildings and in future broadband access networks. Its NEXTPSA and FEXTPSR are given by:

$$NEXTPSA_5 = 61.5 - 6 \log\left(\frac{n}{4}\right) - 15 \log(f) \quad (7)$$

$$FEXTPSR_5 = 55 - 6 \log\left(\frac{n}{4}\right) - 10 \log(f^2 l) \quad (8)$$

For NEXT, the NEXTPSA in dB is subtracted from the PSD in dBm/Hz transmitted by the Disturbing System to obtain the PSD of the NEXT noise at the receiver input. With PSD in dBm/Hz, the noise PSD N_i at the receiver input is:

$$N_i = PSD_i(f) - NEXTPSA(f) \quad (9)$$

For FEXT, the FEXTPSA Ratio in dB and the line attenuation in dB are both subtracted from the PSD in dBm/Hz transmitted by the disturbing system. The FEXT noise PSD F_i at the receiver input is:

$$F_i = PSD_i(f) - FEXTPSR(f) - A(f) \quad (10)$$

where $A(f)$ is the line attenuation in dB.

5.2.2 Transmit Power Spectral Densities of Disturbing Systems

The transmit Power Spectral Density (PSD) of the Disturbing Systems are modelled as templates which have been obtained from the relevant standards and system descriptions as follows. The key requirement is that, for a standard which has a line code and PSD mask defined, the template provides a close approximation to the real transmit PSDs of systems which meet the standard. Hence the following approach:

- (a) The midband PSD in the template is taken to be the nominal value specified in the relevant standard; and
- (b) The remainder of the template, in the regions of high and low frequency rolloff, should be less than or equal to the mask in the standard, and attempt to more closely follow the actual ideal PSD dictated by the line code. Several such templates have been drawn from the ANSI T1.417-2003 and ITU-T Recommendations G.992.3 and G.992.5. Others such as those for SHDSL (ITU G.991.2) are drawn directly from the relevant standard.

For systems which are in common use but are not standards or draft standards, templates have been based on ideal transmit PSDs (E1) or on obvious extensions from similar standard systems.

Note that all noise models must include an additional -140 dBm/Hz of white Gaussian noise.

These templates are exactly the same as the PSDs in the Group A masks which are given for the exchange end in the Appendices to Part 3 of this code and for the customer end in

the Appendices to AS/ACIF S043.2:2005. Appendix A of this Part summarizes the types and origins of transmit PSD models and masks used for the Disturbing Systems in the analysis. The table also gives the relevant frequency at which any range restrictions for each technology are to be converted to attenuation in dB for application to cable types other than the 0.4mm PIUT cable analysed.

5.2.3 Noise Power Summation Method

The FSAN model is adopted by ACIF for the summation of crosstalk noise. T1.E1.4/98-189 provides a detailed description and justification of that model.

The model states that when summing multiple NEXT disturbers (or multiple FEXT, but not NEXT and FEXT together), the NEXT noise powers N_i in dB must be added as follows to give the total noise power N .

$$N = 6 \log_{10} \left[\sum_i 10^{N_i/6} \right] \quad (11)$$

When adding NEXT to FEXT and other noise, the noises are added directly in mW/Hz, where N and F are in dB, viz.

$$TotalNoise(dB) = 10 \log_{10} \left[10^{N/10} + 10^{F/10} \right] \quad (12)$$

5.3 Transceiver Models for Basis Systems

A transceiver model has been developed for each Basis System. For each Basis System transceiver model it is important to ensure insofar as possible that the computed transmission performances are representative of those achievable with real equipment operating in the real network.

The underlying aim is to develop models that are representative of the majority of equipment likely to be deployed for each potential basis xDSL type. Consequently each model has been first developed in an ideal form, and then adjusted to account for the non-idealization effects of real equipment. The adjustments have been made either against the transmission performance specifications of an appropriate international Standard or draft Standard, or against the known measured performances of relevant commercially available equipment. The adjustment in dB which must be applied to the ideal receiver performance is quoted for each of the Basis Systems in Clauses 5.3.1 to 5.3.4 of Part 2 of this Code.

It is important to note here, that for each technology the degree of adjustment has been chosen so as to align the model performances with those achievable with well engineered equipment, but not with the highest attainable by unrepresentative very high state-of-the-art systems.

The process just referred to for aligning model performances with those of actual equipment inherently incorporates with it one means of assessing the veracity of the models in question. In addition, the majority of assessments reported here have been obtained using two independently developed computer programs for each basis

transceiver. Thus the estimates of each program have been verified against those of the other.

Trellis coding is used in several types of DSL transceivers, and a coding gain in dB is applied to account for the advantage thereby obtained. Generally, the trellis coder adds additional redundant bits to the data symbols, and then uses the redundant information to make more accurate decisions in a noisy environment.

A Decision Feedback Equaliser (DFE) is used in several DSL receivers to optimize the SNR at the decision point of the receiver. Because the performance is dependent on the number of taps and other design features of the digital signal processing used, it has been decided to use ideal (infinite tap count) DFEs for these studies, and then to degrade all DFE-based receivers by an amount to account for practical realisation.

5.3.1 ADSL Transceiver Model

The ADSL DMT transceiver is based on an ideal model similar to that due to Cioffi (Ref. 1) with parameters according with ITU-T Recommendation G.992.1. Specifically:

- (a) Bit allocation is based on transmit PSD of -38dBm/Hz up and -40 dBm/Hz down for all allocated subchannels (or -3.65 dB per 4.3125 kHz sub-channel) together with up to +/- 1.5 dB power adjustment to achieve equal signal to noise ratio in all subchannels;
- (b) Sub-channels used are determined from the standard PSD masks. The downstream mask for FDD operation employs the reduced NEXT option (i.e. non-overlapped spectra). The subchannels used for upstream are 6 to 31 and for downstream 38 to 256 with subchannel 64 reserved for the pilot tone.
- (c) Maximum bits per sub-channel = 14 (up and down);
- (d) Minimum bits per sub-channel = 2 (up and down);
- (e) Assumed coding gain of combined Reed-Solomon FEC and Trellis coding = 3 dB;
- (f) Overhead rate (with fast and slow buffers) = 192 kbit/s down, and 128 kbit/s up;
- (g) Power cutback (refer to Table C-2 in Part 3 of this Code) and
- (h) No additional overhead FEC.

To just meet the requirements of G.992.1 Region A test loops and test noise conditions, the receiver model used for this Basis System is assumed to be the ideal model.

5.3.2 ADSL2+ Transceiver Model

The ADSL2+ DMT transceiver is based on an ideal model similar to that due to Cioffi (Ref. 1) though with parameters according with ITU-T Recommendation G.992.5. Specifically:

- (a) Bit allocation is based on the non-overlapped downstream and upstream transmit PSD templates defined in Table A.3 and A.5 of G.992.5 respectively.

- (b) Sub-channels used are determined from the Standard PSD masks. The downstream mask for FDD operation employs the reduced NEXT option (i.e. non-overlapped spectra). The subchannels used for upstream are 6 to 31 and for downstream 38 to 511 with subchannel 64 reserved for the pilot tone;
- (c) Max bits per sub-channel = 15 (up and down);
- (d) Minimum bits per sub-channel = 1 (up and down);
- (e) Assumed coding gain of combined Reed-Solomon FEC and Trellis coding = 4.2 dB;
- (f) Overhead rate (with fast and slow buffers) = 192 kbit/s down, and 128 kbit/s up;
- (g) Power cutback (refer to Table C-2 in Part 3 of this Code) and
- (h) No additional overhead for trellis coding or FEC.

5.3.3 ISDN-BR Transceiver Models

The 2B1Q transceiver model employs an ideal DFE-based representation that is adjusted to account for the limitations of representative actual systems. The ideal DFE-based representation is that set out in the draft ANSI Spectrum Management Standard (Ref. 2). The representation has been developed from the optimal mean-square error formulation due to Salz (Ref. 3). The transmit PSD is assumed to be ideal –

- 2B1Q line coded full width rectangular pulses, filtered by a 2nd order Butterworth filter at the baud rate.
- The total transmitted power integrated over the frequency range from 0 to the baud rate shall be exactly +14 dBm

To just meet the requirements of G.961 or G.991.1 test loops, the receiver model for this Basis System is assumed to have 5 dB worse performance than the ideal receiver.

5.3.4 E1-HDB3 Transceiver Model

The E1-HDB3 receiver is modelled as an ideal linear equaliser with the following characteristics (some from G.703):

- (a) Assumed 100% raised cosine (frequency domain) pulse shape at receiver eye;
- (b) Half-width rectangular transmit pulse shape, with peak amplitude = 3.0V; and
- (c) Baud rate = 2048 kbaud.

The difference between this ideal equaliser and well designed practical receivers is 1-2 dB. Hence the receiver model for this Basis System is assumed to have 2 dB worse performance than the ideal receiver.

Tests for interference into the E1 Basis System must include 4 E1 NEXT disturbers in the opposite direction of transmission which are not in the same cable unit as the Basis System (these are conservatively assumed to cause 10 dB less NEXT than for disturbers within the same cable unit), 4 E1 FEXT

disturbance in the same direction of transmission which are in the same cable unit, and 4 disturbers of the Deployment Class under test. The requirement for the protection of legacy E1 Basis Systems is for a BER of 10^{-7} with a margin of 6 dB at a range of 1 km. If this test fails with the systems under test in the same cable unit, then pair separation at the lowest NRP of that Deployment Class is required.

5.3.5 Voiceband

This code does not directly specify a benchmark performance for voiceband systems but instead controls the interference into voiceband systems by limiting the transmit PSD of all disturbing systems within the voiceband.

The total power of any disturbing system in the frequency band $0 < f < 4$ kHz shall be less than -10 dBm (600Ω).

5.3.6 SHDSL and ESHDSL Transceiver Model

The SHDSL transceiver model employs an ideal DFE-based representation that is adjusted to account for the limitations of representative actual systems.

The necessary target SNR in order to achieve a given Margin is equal to:

$$SNR_{dB} = SNR_{req} - \text{Coding Gain} + \text{Implementation Loss} - \text{Margin}$$

where:

- SNR_{req} is 27.71 dB for Coded 16-PAM systems and 33.80 dB for Coded 32-PAM systems.
- Coding gain is 5dB
- Implementation Loss is 2dB
- Margin is 6dB

The Signal to Noise ratio is given by the discrete form of the DFE-based SNR formula, SNR_{dB} , given below:

$$SNR_{dB} = \frac{1}{M} \sum_{k=1}^M 10 \log_{10} \left(\frac{1 + \frac{S(f_{sym} - f_k) |H(f_{sym} - f_k)|^2}{N(f_{sym} - f_k)} + \frac{S(f_k) |H(f_k)|^2}{N(f_k)}}{\frac{S(2f_{sym} - f_k) |H(2f_{sym} - f_k)|^2}{N(2f_{sym} - f_k)} + \frac{S(f_{sym} + f_k) |H(f_{sym} + f_k)|^2}{N(f_{sym} + f_k)}} \right)$$

where:

$S(f)$ shall be the nominal far-end transmit signal power spectral density,

$|H(f)|^2$ shall be the magnitude squared of the ideal loop insertion gain function described in section 5.1,

$N(f)$ shall be the injected crosstalk noise power spectral density as described in section 5.2.

f_{sym} shall be the transmit symbol rate and is equal to (payload rate + overhead) / (number of bits per symbol). A coded

16-PAM system has 3 bits per symbol while a coded 32-PAM system has 4 bits per symbol. Overhead is 8 kbit/s.

For this application use $f_k = k$ kilohertz, $k = 1 \dots M$, where M is the maximum value of k such that $M < f_{sym} \leq (M+1)$.

The equation for the nominal PSD $S(f)$ is defined in G.991.2.

6 EXPECTED WORST CASE WIDEBAND NOISE MASK ON THE ULLS

- 6.1 This section describes the development and definition of an indicative Wideband noise test for an ULLS. The specification accounts for crosstalk noise from disturbing systems belonging to Deployment Classes and deployed according to Deployment Rules. However, it should be noted that it excludes all other possible noise components, such as impulsive noise, and RFI from AM broadcast stations, which are likely to be encountered on actual lines. The expected worst case noise PSD has been calculated for all possible Disturbing Systems when deployed from a ULLS-NRP at a single location. This model applies to both Deployment States A and B as described in Part 1 of this Code. The process for determination of this worst case noise is as follows:
- (1) Determine the 1% worst case crosstalk noise PSD at each end of the cable for 9 disturbers of the given Deployment Class at each end within a 10-pair cable unit;
 - (2) Repeat for all Deployment Classes at a given line length;
 - (3) Find the maximum of the 1% worst case crosstalk noise PSD over all classes at the given length;
 - (4) Repeat at several lengths up to 5 km of 0.4mm PIUT cable, to obtain a length dependent set of noise PSDs at the customer end; and
 - (5) Convert the range parameter on the curves to dB at 300 kHz to allow reference to cable types other than 0.4mm PIUT.
- 6.2 The worst case noise mask of power in 3 kHz at the Deployment Reference Point for an asymmetric Deployment Class is described in Figure 6-1 and Table 6-1 of Part 2 of this Code. The worst case noise PSD masks at the ULLS-EURP in Figure 6-2 and Table 6-2 of Part 2 of this Code are plotted with the attenuation at 300 kHz as a parameter.
- 6.3 In Deployment State A, the worst case noise mask applies with the attenuation parameter based on the range from the Highest NRP.
- 6.4 In Deployment State B;
- (1) the network end noise mask in Figure 6-1 applies to all NRPs between the Highest NRP and the Nominated Lower NRP.
 - (2) the customer end noise mask in Figure 6-2 applies where the attenuation parameter is measured from the Nominated Lower NRP. Note that this corresponds to more severe customer end noise for systems fed from the exchange in Deployment State B, compared with Deployment State A.
- 6.5 The worst case wideband noise masks represent the 1% worst case noise PSD due to crosstalk from all Deployment Class

Systems on the reference 0.4mm PIUT cable. These masks are expected to be exceeded in less than 1% of cases on unit cables, but may be exceeded in a larger percentage of cases on quad cable.

- 6.6 The effect of radio frequency interference on ULLS noise is to introduce large spikes associated with AM radio broadcasts; these spikes are tolerated by most DSL systems and they should not be considered exceedances.
- 6.7 Exceedance of the mask does not necessarily result in system failure because the frequency bands used by the systems may not align with the frequencies at which exceedance occurs. System failures may occur even when the mask is not exceeded because of wideband interference due to combinations of multiple crosstalk and external noise sources. Therefore the mask is only indicative of a more severe noise environment.

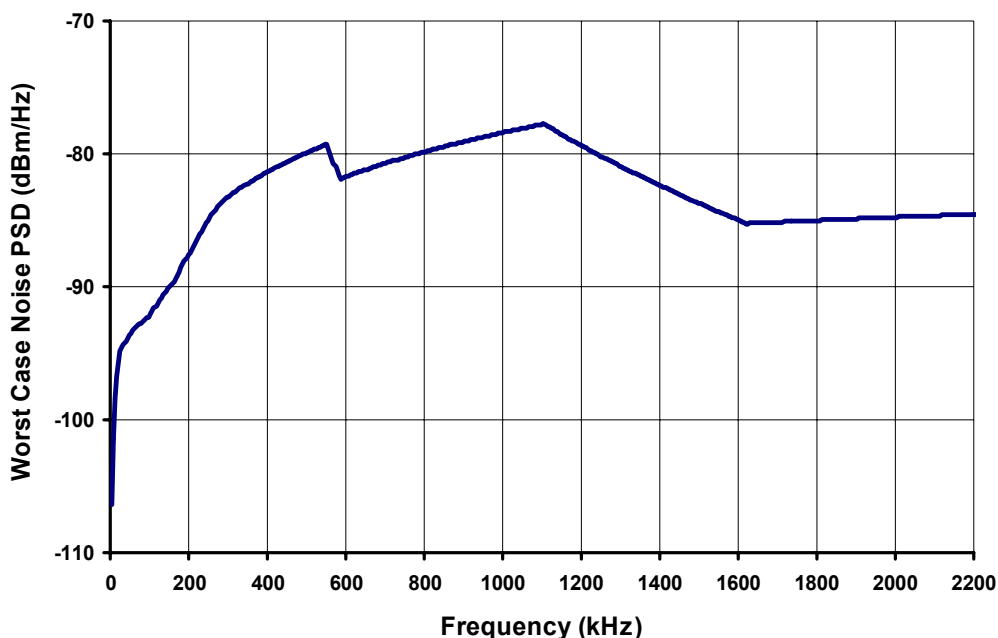

FIGURE 6-1

Worst case noise power in dBm/Hz at the Highest NRP in Deployment State A

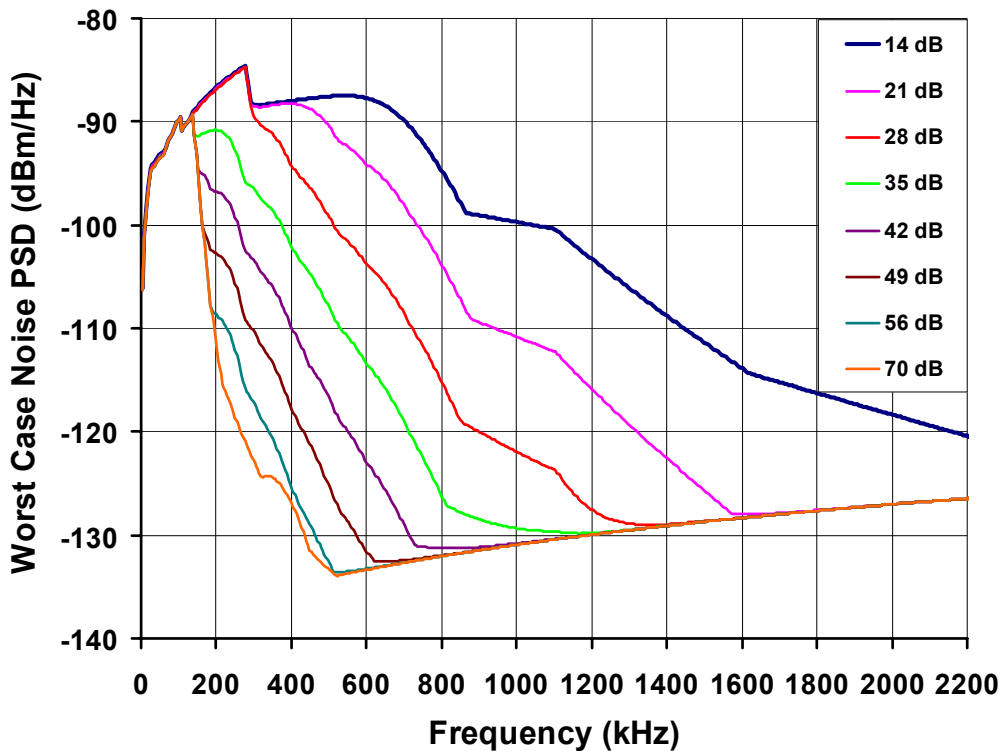

Figure 6-2

Worst case noise power in dBm/Hz at the Customer Network Boundary Point as a function of the cable attenuation at 300 kHz from the Highest NRP in Deployment State A, and from the Nominated Lower NRP in Deployment State B.

7 REFERENCES

1. Cioffi, J. "A Multicarrier Primer". ANSI Standards Committee T1 Submission, T1E1.4/91-157, 11th November 1991.
2. ANSI T1.417-2003.Spectrum Management for Loop Transmission Systems. Sept. 2003.
3. Salz, J. "Optimum Mean-Square Decision Feedback Equalization". BSTJ, October 1973, pp1341-1373.
4. FSAN VDSL working group " A new analytical method for NEXT and FEXT noise calculation", T1.E1.4 contribution 98-189, 28 May 1998.
5. ITU-T Recommendation G.991.2 " SHDSL"

APPENDIX A TRANSMIT PSD TEMPLATES FOR DEPLOYMENT CLASS SYSTEMS

This Appendix gives the transmit PSD templates for the Deployment Class Systems which are used to define the disturbing systems in the calculation of Basis System performance. These templates correspond to the Group A requirements for the Deployment Classes referenced in Part 3 of this Code.

Note that the Reference Frequency is always derived from the upper rate of the deployment class, and may not match exactly with a column in Table A-2 of Part 1 of this Code.

| Deployment Class | Reference to source of Transmit PSD Template | Midband PSD or other parameter | Typical Technology (informative) | Reference frequency for class (kHz) (Note 2) |
|------------------|--|---|---|--|
| 1a | Removed while revising ACIF C559:2003 | | E1 HDB3 ≤ 0.7 km | 1024 |
| 1b | Table B-2 of Part 3 of this Code Ideal based on G.703. (Only for assessment of interference into E1 Basis System. Not to be used as an interferer into other Basis Systems) | $V_{\text{peak}} = 3.1\text{V}$ | E1 HDB3 | 1024 |
| 2a | Reserved | | | |
| 3a | Systems complying with class 3a shall comply with the requirements of AS/ACIF S043.3, AS/ACIF S002 or AS/ACIF S003 or AS/ACIF S006 | Used ISDN mask from 4a for high frequency content | Low Band | - |
| 4a | Table A-2 of S043-2 at both ends | -32 dBm/Hz | ISDN BR 2B1Q | 40 |
| 5a | Table B-2 of S043-2 at both ends | Based on Formula in equation (14) | Modified Rolloff SHDSL to 576 kbit/s | 96 |
| 5b | Table C-2 of S043-2 at NBP Table O-2 of Part 3 of this Code at NRP | Based on Formula in equation (14) | Modified Rolloff SHDSL with reduced power to 784 kbit/s | 131 |
| 6a | Table D-2 of S043-2 at NBP Table C-3 of Part 3 of this Code at NRP | Up -38 dBm/Hz Down -40 dBm/Hz | ADSL FD | 300 |
| 6b | Removed while revising ACIF C559:2003 | | ADSL Lite | 300 |
| 6c | Table F-2 of S043-2 at NBP Table E-2 of Part 3 of this Code at NRP | Up -38 dBm/Hz Down -40 dBm/Hz | ADSL over ISDN | 300 |

| Deployment Class | Reference to source of Transmit PSD Template | Midband PSD or other parameter | Typical Technology (informative) | Reference frequency for class (kHz) (Note 2) |
|------------------|---|------------------------------------|--|--|
| 6d | Table D-2 of S043-2 at NBP Table F-2 of Part 3 of this Code at NRP | Up -38 dBm/Hz Down -40 dBm/Hz | ADSL EC | 300 |
| 6e | Table D-2 of S043-2 at NBP Table G-2 of Part 3 of this Code at NRP | Up -38 dBm/Hz Down -50 dBm/Hz | ADSL FD Low Power | 300 |
| 6f | Table D-2 of S043-2 at NBP Table H-2 of Part 3 of this Code at NRP | Up -38 dBm/Hz Down -40 dBm/Hz | ADSL FD Limited carriers | 300 |
| 6g | G.992.3 Annex L; Table L.4/G.992.3 downstream Table L.7/G.992.3 upstream Table W-2 of S043-2 at NBP Table L-2 of Part 3 of this Code at NRP | Up -36.4 dBm/Hz Down -37 dBm/Hz | Re-ADSL2 (upstream mask 1) | 300 |
| 6h | G.992.5 Tables A.3 downstream, and A.5 upstream Table X-2 of S043-2 at NBP Table M-2 of Part 3 of this Code at NRP | Up -38 dBm/Hz Down -40 dBm/Hz | ADSL2 and ADSL2+ (non-overlapped mode) | 300 |
| 6i | G.992.5 Annex I, Table I-4 upstream Table A.3/G.992.5 downstream Table Y-2 of S043-2 at NBP Table N-2 of Part 3 of this Code at NRP | Up -38 dBm/Hz Down -40 dBm/Hz | ADSL2+ All Digital (non-overlapped mode) | 300 |
| 6j | G.992.3 and G.992.5 Annex M | Up -39 dBm/Hz Down -40 dBm/Hz | ADSL2 and ADSL2+ non overlapped spectrum with extended upstream bandwidth (Annex M) Mask EU-40 | 300 |
| 6k | G.992.3 and G.992.5 Annex M | Up -40.1 dBm/Hz Down -40 dBm/Hz | ADSL2 and ADSL2+ non overlapped spectrum with extended upstream bandwidth (Annex M) Mask EU-52 | 300 |
| 6l | G.992.3 and G.992.5 Annex M | Up -40.4 dBm/Hz Down -40 dBm/Hz | ADSL2 and ADSL2+ non overlapped spectrum with extended upstream | 300 |

| Deployment Class | Reference to source of Transmit PSD Template | Midband PSD or other parameter | Typical Technology (informative) | Reference frequency for class (kHz) (Note 2) |
|---------------------|---|---|--|--|
| | | | bandwidth (Annex M) Mask EU-56 | |
| 6m | G.992.3 and G.992.5 Annex M | Up -40.7 dBm/Hz Down -40 dBm/Hz | ADSL2 and ADSL2+ non overlapped spectrum with extended upstream bandwidth (Annex M) Mask EU-60 | 300 |
| 6n | G.992.3 and G.992.5 Annex M | Up -41 dBm/Hz Down -40 dBm/Hz | ADSL2 and ADSL2+ non overlapped spectrum with extended upstream bandwidth (Annex M) Mask EU-64 | 300 |
| 7a to 7j | Removed while revising ACIF C559:2003 | | SDSL (all speeds) | |
| 8a | Removed while revising ACIF C559:2003 | | HDSL 2B1Q 784 kbit/s | 196 |
| 8b | Frequency scaled ANSI SM Class 3 template. Table O-2 of S043-2 at both ends | -39 dBm/Hz | HDSL 2B1Q 1168 kbit/s | 292 |
| 8c,d | Removed while revising ACIF C559:2003. | | HDSL 2B1Q 2320 kbit/s | 580 |
| 9a | G.991.2 Template Table Q-4 of S043-2 at both ends | Based on Formula in equation (13) | SHDSL (up to 576 kbit/s) | 96 |
| 9b | G.991.2 Template Table Q-4 of S043-2 at NBP Table J-4 of Part 3 of this Code at NRP | Based on Formula in equation (13) reduced by 3.5 dB | SHDSL (up to 776 kbit/s, reduced power) | 132 |
| 9c | G.991.2 Template Table Q-4 of S043-2 at both ends | Based on Formula in equation (13) | SHDSL (up to 776 kbit/s) | 132 |
| 9d | G.991.2 Template Table Q-4 of S043-2 at both ends | Based on Formula in equation (13) | SHDSL (up to 1160 kbit/s) | 196 |
| 9e | G.991.2 Template Table Q-4 of S043-2 at both ends | Based on Formula in equation (13) | SHDSL (up to 1544 kbit/s) | 2597 |
| 9f | G.991.2 Template Table Q-4 of S043-2 at both ends | Based on Formula in equation (13) | SHDSL (up to 2056 kbit/s) | 344 |

| Deployment Class | Reference to source of Transmit PSD Template | Midband PSD or other parameter | Typical Technology (informative) | Reference frequency for class (kHz) (Note 2) |
|------------------|---|-----------------------------------|-------------------------------------|--|
| 9g | G.991.2 Template Table Q-4 of S043-2 at both ends | Based on Formula in equation (13) | SHDSL (up to 2312 kbit/s) | 388 |
| 9h | G991.2 Template Table Q-4 of S043-2 at both ends | Based on Formula in equation (13) | SHDSL (up to 1800 kbit/s) | 300 |
| 9i | G991.2 Annex K Table Z-4 of S043-2 at both ends | Based on Formula in equation (13) | ESHDSL (up to 2624 kbit/s) | 439 |
| 9j | G991.2 Annex K Table Z-4 of S043-2 at both ends | Based on Formula in equation (13) | ESHDSL (up to 2880 kbit/s) | 481 |
| 9k | G991.2 Annex K Table Z-4 of S043-2 at both ends | Based on Formula in equation (13) | ESHDSL (up to 3072 kbit/s) | 513 |
| 9l | G991.2 Annex K Table Z-4 of S043-2 at both ends | Based on Formula in equation (13) | ESHDSL (up to 3264 kbit/s) | 545 |
| 9m | G991.2 Annex K Table Z-4 of S043-2 at both ends | Based on Formula in equation (13) | ESHDSL (up to 3456 kbit/s) | 577 |
| 9n | G991.2 Annex K Table Z-4 of S043-2 at both ends | Based on Formula in equation (13) | ESHDSL (up to 3648 kbit/s) | 609 |
| 9o | G991.2 Annex K Table Z-4 of S043-2 at both ends | Based on Formula in equation (13) | ESHDSL (up to 3840 kbit/s) | 641 |
| 9p | G991.2 Annex K Table Z-4 of S043-2 at both ends | Based on Formula in equation (13) | ESHDSL (up to 5376 kbit/s) (Note 1) | 673 |
| 9q | G991.2 Annex K Table Z-4 of S043-2 at both ends | Based on Formula in equation (13) | ESHDSL (up to 5696 kbit/s) (Note 1) | 713 |

TABLE A-1

List of PSD Templates for Deployment Classes: for use in determining Unacceptable Interference into a Basis System

NOTE 1: only 4 bits/symbol available at this data rate in the ESHDSL Recommendation.

NOTE 2: Reference Frequency here may not align exactly with the column in Table A-2 in Part 1 of this Code. The Reference Frequency is always derived from the upper-rate of the Deployment Class.

Midband PSDs and templates for the SHDSL and ESHDSL systems with variable rate in Table A-1 of Part 2 of this Code above are based on formulae which scale the PSD while retaining the same total transmit power for all rates.

For SHDSL and ESHDSL the transmit PSD template is defined in G.991.2. The midband PSD and the baud rate are related by equation 13:

$$\text{Midband_PSD}(dBm / Hz) = 10 \log_{10} \left(\frac{K}{135B} \right) \quad (13)$$

where the baud rate B (kbaud) is equal to the bit rate (kbit/s) divided by the number of bits per symbol (3 using 16-TCPAM encoding, 4 using 32-TCPAM encoding), and the constant K is given by:

if $B < 2056/3$, $K=7.86$,

if $B \geq 2056/3$, $K=9.9$. (14)



Published by:
**THE AUSTRALIAN
COMMUNICATIONS
INDUSTRY FORUM LTD**

Level 9
32 Walker Street
North Sydney
NSW 2060 Australia

Correspondence:
PO Box 444
Milsons Point
NSW 1565

T 61 2 9959 9111
F 61 2 9954 6136
TTY 61 2 9923 1911
E acif@acif.org.au
www.acif.org.au
ABN 56 078 026 507

Care should be taken to ensure that material used is from the current version of the Standard or Industry Code and that it is updated whenever the Standard or Code is amended or revised. The number and date of the Standard or Code should therefore be clearly identified. If in doubt please contact ACIF.