

**COMMUNICATIONS
ALLIANCE LTD**



DRAFT INDUSTRY CODE

DR C559:2011

PART 1

ULLS PERFORMANCE REQUIREMENTS

DRAFT FOR PUBLIC COMMENT

Issued: 5 December 2011

Comments close: 5pm AEDT 12 January 2012

**DR C559:2011 Unconditioned Local Loop Service (ULLS)
Network Deployment Industry Code**

First published as ACIF C559:2001

Second edition as ACIF C559:2002

Third edition as ACIF C559:2003

Fourth edition as ACIF C559:2005

Fifth edition as ACIF C559:2006

This draft Code is released for public comment as DR C559:2011

Communications Alliance Ltd (formerly Australian Communications Industry Forum Ltd) was formed in 2006 to provide a unified voice for the Australian communications industry and to lead it into the next generation of converging networks, technologies and services.

Disclaimers

- 1) Notwithstanding anything contained in this Industry Code:
 - a) Communications Alliance disclaims responsibility (including where Communications Alliance or any of its officers, employees, agents or contractors has been negligent) for any direct or indirect loss, damage, claim, or liability any person may incur as a result of any:
 - i) reliance on or compliance with this Industry Code/Guideline;
 - ii) inaccuracy or inappropriateness of this Industry Code; or
 - iii) inconsistency of this Industry Code with any law; and
 - b) Communications Alliance disclaims responsibility (including where Communications Alliance or any of its officers, employees, agents or contractors has been negligent) for ensuring compliance by any person with this Industry Code/Guideline.
- 2) The above disclaimers will not apply to the extent they are inconsistent with any relevant legislation.

Copyright

© Communications Alliance Ltd 2011

This document is copyright and must not be used except as permitted below or under the Copyright Act 1968. You may reproduce and publish this document in whole or in part for your or your organisation's own personal or internal compliance, educational or non-commercial purposes. You must not alter or amend this document in any way. You must not reproduce or publish this document for commercial gain without the prior written consent of Communications Alliance. Organisations wishing to reproduce or publish this document for commercial gain (i.e. for distribution to subscribers to an information service) should apply to Communications Alliance by contacting the Communications Alliance Commercial Manager at info@commsalliance.com.au.

INTRODUCTORY STATEMENT

The ***Unconditioned Local Loop Service (ULLS) Network Deployment*** Code (C559:2012) replaces the registered ***Unconditioned Local Loop Service (ULLS) Network Deployment*** Code ACIF (C559:2006).

The purpose of the changes are to:

- Update some cable loss values for 0.4mm PIUT cable in Table A-2 of Part 1 of the Code;
- Add cable loss values for all cable types at 3750kHz in Table A-2 of Part 1 of the Code; and
- Remove unnecessary reference to the network boundary point;
- update references from 'ACIF' to 'Communications Alliance' plus correct some typographical errors.

The ***Unconditioned Local Loop Service (ULLS) Network Deployment*** Code is designed to establish performance requirements which systems must meet and only systems which meet the requirements of this Code may be operated on the ULLS.

Peter Cooke

Chair

ULLS Network Deployment Revision Working Committee

DECEMBER 2011

TABLE OF CONTENTS

1	GENERAL	4
1.1	Introduction	4
1.2	Registration by the ACMA	4
1.3	Scope	4
1.4	Objectives - Background	5
1.5	Objectives	6
1.6	Code review	7
1.7	Powers of the Telecommunications Industry Ombudsman to handle complaints under the Code	7
2	ACRONYMS, DEFINITIONS AND INTERPRETATIONS	8
2.1	Acronyms	8
2.2	Definitions	12
2.3	Interpretations	18
3	BILATERAL AGREEMENTS	20
4	REFERENCE ARCHITECTURE FOR SERVICES USING THE ULLS	21
4.1	Background	21
4.2	ULLS Reference Architecture	22
4.3	Single and Multiple Feed Distribution Areas	22
4.4	Performance Implications of Single and Multiple Feed DAs	24
4.5	Deployment States A and B	24
4.6	Deployment Reference Points	25
4.7	Lowest Asymmetric System Feed Point	25
5	PERFORMANCE REQUIREMENTS FOR OPERATION OF SYSTEMS USING THE ULLS	27
5.1	General	27
5.2	Rules for Operation of Systems using the ULLS	28
5.3	Operation of Deployment Class Systems	29
5.4	Operation of Non-Deployment Class Systems	30
5.5	Use of More Than One System Type on a single ULLS	33
5.6	Trials and Extraordinary or Temporary uses	33
6	POWER FEEDING OF REMOTE EQUIPMENT USING THE ULLS	35
6.1	Overview	35
6.2	General Requirements of Power Feeding Equipment connected to ULLS	35
6.3	Safety Requirements for Power Feeding into Customer Premises	36
7	COMPLIANCE WITH PERFORMANCE REQUIREMENTS UNDER THIS CODE	38
7.1	Overview	38
7.2	Responsibility for Compliance	38
7.3	Compliance with Deployment Class Requirements	38
7.4	Standards Compliance	38
7.5	Laboratory Compliance	38
7.6	Operational Compliance	39

8	OPERATION OF SYSTEMS IN CUSTOMER PREMISES (INFORMATIVE)	40
9	CONDUCT OF EMPLOYEES, AGENTS, CONTRACTORS AND DEALERS	41
10	REFERENCES	42
APPENDIX		45
A	METHOD FOR DETERMINATION OF DEPLOYMENT LIMIT COMPLIANCE.	45
B	MEASUREMENT METHODOLOGY	47
PARTICIPANTS		53

1 GENERAL

1.1 Introduction

- 1.1.1 Section 112 of the *Telecommunications Act 1997* (the Act) sets out the intention of the Commonwealth Parliament that bodies and associations representing sections of the telecommunications industry develop industry codes relating to the telecommunications activities of participants in those sections of the industry.
- 1.1.2 The development of the Code has been facilitated by Communications Alliance through a Working Committee comprised of representatives from the telecommunications industry.
- 1.1.3 The Code should be read in the context of other relevant codes, guidelines and documents.
- 1.1.4 The Code should be read in conjunction with related legislation, including:
- (a) the Act; and
 - (b) the *Telecommunications (Consumer Protection and Service Standards) Act 1999 (Cth)*; and
 - (c) the *Competition and Consumer Act 2010 (Cth)*.
- 1.1.5 If there is a conflict between the requirements of the Code and any requirements imposed on a Carrier or Carriage Service Provider (CSP) by statute, the Carrier or CSP will not be in breach of the Code by complying with the requirements of the statute.
- 1.1.6 Compliance with this Code does not guarantee compliance with any legislation. The Code is not a substitute for legal advice.
- 1.1.7 Statements in boxed text are a guide to interpretation only and not binding as Code rules.

1.2 Registration by the ACMA

The Code is to be submitted to the Australian Communications and Media Authority for registration under section 117 of the Act.

1.3 Scope

- 1.3.1 The Code applies to the following sections of the telecommunications industry under section 110 of the Act:
- (a) Carriers; and
 - (b) Carriage Service Provider.
- 1.3.2 The Code deals with the following telecommunications activities as defined in section 109 of the Act:

- (a) carrying on business as a Carrier; or
 - (b) carrying on business as a Carriage Service Provider; or
 - (c) supplying Goods or Service(s) for use in connection with the supply of a Listed Carriage Service.
- 1.3.3 The Code applies to a Carrier or Carriage Service Provider that uses the ULLS.
- 1.3.4 The Code does not apply to
- (a) systems operated on conditioned Communications Wire;
 - (b) systems deployed and in operation on Communications Wire prior 15 August 2001.

NOTE: ACIF published the original version of this document, ACIF C559:2001 Unconditioned Local Loop Service (ULLS) Network Deployment Rules Industry Code, on 15 August 2001.

- 1.3.5 This Code does not apply to the conditioning of unconditioned local loops (including the Access Provider's unconditioned local loops).
- 1.3.6 Clause 5.2.1 of Part 1 of this Code does not apply to a Trial System or Extraordinary and Temporary Use System.

NOTE: Clause 5.6 of Part 1 of this Code defines when a system is a Trial or Temporary and Extraordinary Use system for the purposes of Clause 1.4 of Part 1 of this Code.

1.4 Objectives - Background

- 1.4.1 Broadband telecommunications systems using the ULLS and other systems in the same cable unit could interfere with each other unless performance requirements are in place to limit such interference. The purpose of this Code is to keep the probability of undue interference into other well-designed systems within acceptable limits by controlling the deployment of each type of system which could be used on the ULLS.
- 1.4.2 This Code establishes performance requirements which systems must meet and only systems which meet the requirements of this Code may be operated on the ULLS.
- 1.4.3 This Code is to be submitted to the Australian Communications and Media Authority for registration under section 117 of the *Telecommunications Act 1997 (Cth.)*.
- 1.4.4 This code replaces:
- (a) ACIF C559:2001 Unconditioned Local Loop Service (ULLS) – Network Deployment Rules Industry Code;
 - (b) ACIF C559:2002 Unconditioned Local Loop Service (ULLS) – Network Deployment Rules Industry Code;

- (c) ACIF C559:2003 Unconditioned Local Loop Service (ULLS) – Network Deployment Rules Industry Code;
- (d) ACIF C559:2005 Unconditioned Local Loop Service (ULLS) – Network Deployment Rules Industry Code; and
- (e) ACIF C559:2006 Unconditioned Local Loop Service (ULLS) – Network Deployment Industry Code.

1.5 Objectives

1.5.1 The objectives of the Code are:

- (a) To protect the integrity of the telecommunications network when systems and services (including Standard Telephone Services) are operated using the ULLS;
- (b) To facilitate the most efficient use of the ULLS for the deployment of carriage services taking into account the nature of access networks and the likely use of the ULLS;
- (c) To limit to an acceptable level the risk of interference between systems and services (including Standard Telephone Services) operated using the ULLS;
- (d) To identify specific Deployment Classes with associated Deployment Rules which, if complied with, will ensure a carrier or carriage service provider will meet the obligations in this Code;
- (e) To prescribe the process by which new Deployment Classes may be identified and new services operated using the ULLS;
- (f) To promote the greatest practical use of industry self-regulation in providing guidance to the telecommunications industry in operating systems using the ULLS;
- (g) To develop performance requirements for the operation of systems using the ULLS that promote the long term interests of end users and the efficiency of the Australian communications industry;
- (h) To facilitate the supply of diverse and innovative carriage services and content services using the ULLS;
- (i) To specify the safety requirements for equipment that uses remote power feeding and is used as part of the operation of a system using the ULLS; and
- (j) To avoid the use of spectrum prior to the consideration by the telecommunications industry of the most efficient use of that spectrum in the operation of systems using the ULLS.

- 1.5.2 This Code is intended to be consistent with the principles set out in the *Competition and Consumer Act 2010 (Commonwealth)* and, in particular, the standard access obligations.

1.6 Code review

The Code will be reviewed after 5 years of the Code being registered by ACMA, or earlier in the event of significant developments that affect the Code or a chapter within the Code.

1.7 Powers of the Telecommunications Industry Ombudsman to handle complaints under the Code

The Code does not confer powers or functions on the TIO under section 114 of the Act.

2 ACRONYMS, DEFINITIONS AND INTERPRETATIONS

2.1 Acronyms

For the purposes of the Code:

2B1Q

means Two Binary One Quaternary (line code)

ACA

means Australian Communications Authority

ACCC

means Australian Competition and Consumer Commission

ACMA

means Australian Communications and Media Authority

ADSL

means Asymmetric Digital Subscriber Line

ADSL2

means Asymmetric Digital Subscriber Line version 2

ADSL2+

means Extended bandwidth ADSL2

AP

means Access Provider

AS

means Access Seeker

CAM

means Customer Access Module

CCF

means Cross Connect Facility

DA

means Distribution Area

DFE

means Decision Feedback Equaliser

DMT

means Discrete Multi Tone

DP

means Distribution Point

DRP

means Deployment Reference Point

DSL

means Digital Subscriber Line

EC

means Echo Cancelling

ECP

means Equipment Connection Point

EPL

means Estimated Power Loss

ESA

means Exchange Serving Area

ESHDSL

means Single-Pair High-Speed Digital Subscriber Line Extended rate

FD

means Frequency Division

FDD

means Frequency Division Duplex

FEC

means Forward Error Correction

FEXT

means Far End Cross Talk

FEXTPSR

means FEXT Power Sum Ratio

FSAN

means Full Services Access Network

HDB3

means High Density Bipolar of order 3 (line code)

HDSL

means High bitrate Digital Subscriber Line

HCLL

means High Capacity Local Loop

IDF

means Intermediate Distribution Frame

ISDN

means Integrated Services Digital Network

MDF

means Main Distribution Frame

NBP

means Network Boundary Point

NEXT

means Near End Cross Talk

NEXTPSA

means NEXT Power Sum Attenuation

NRP

means Network Reference Point

NTD

means Network Termination Device

PIUT

means Paper Insulated Unit Twin

POI

means Point of Interconnection

POI-ULLS

means Point Of Interconnection with respect to the ULLS

POTS

means Plain Old Telephone Service

PSD

means Power Spectral Density

PSTN

means Public Switched Telephone Network

ReADSL

means Reach extended ADSL2

RFT

means Remote Feeding Telecommunications

RFT-C

means Remote Feeding Telecommunications-Current limited

RFT-V

means Remote Feeding Telecommunications-Voltage limited

RIM

means Remote Integrated Multiplexer

SDSL

means Symmetric Digital Subscriber Line

SHDSL

means Single-pair High-speed Digital Subscriber Line

SNR

means Signal to Noise Ratio

TCPAM

means Trellis Coded Pulse Amplitude Modulation

ULLS

means Unconditioned Local Loop Service

ULLS-EURP

means ULLS End User Reference Point

ULLS-NRP

means ULLS Network Reference Point

VDSL

means Very high speed Digital Subscriber Line

2.2 Definitions

For the purposes of the Code:

Access Provider

has the meaning given by section 152AR of the *Competition and Consumer Act 2010* (Commonwealth).

Access Seeker

has the meaning given by section 152AG of the *Competition and Consumer Act 2010* (Commonwealth).

Act

means the *Telecommunications Act 1997* (Commonwealth).

Basis System

means a telecommunications system that has a determined Spectral Compatibility Benchmark.

NOTE: Some, but not all, Legacy Systems are Basis Systems. Basis Systems provide the basis for ensuring network integrity.

Bridged Tap

means a length of unterminated Communications Wire connected in parallel across a Communications Wire.

Broadband

means frequencies above 20 kHz.

Cable Unit

means a group of twisted pairs that are wrapped together within a main, branch or distribution cable.

Calculated Attenuation

means the calculated sum of the attenuations in dB of all inline cable segments, excluding Bridged Taps, of the ULLS Communications Wires between specified end points at any given frequency.

Carriage Service Provider

has the meaning given by section 87 of the *Telecommunications Act 1997* (Commonwealth).

Carrier

has the meaning given by section 7 of the *Telecommunications Act 1997* (Commonwealth).

Communications Wire

means a copper or aluminium based wire, forming part of a public telecommunications network.

Compliant System

means a system that complies with this Code.

Cross Connect Facility

means a termination device for multiple cables consisting of wire terminating modules or strips, allowing Communications Wires from one or more cables to be connected to Communications Wires in another cable but does not include cable joints where the connections are considered to be permanent and not accessible.

NOTE: A CCF logically has an A (customer) and B (network) side, but does not have to be actually implemented as two discrete sides as in a traditional distribution frame. The major types of CCF within the local loop are located within traditional exchange buildings (MDFs), within roadside cabinets and specific street furniture (pillars). There may also be CCFs within customer premises.

Customer Access Module

means a device that provides ring tone, ring current and battery feed to customers' equipment. Examples are Remote Subscriber Stages, Remote Subscriber Units, Integrated Remote Integrated Multiplexers and Non-Integrated Remote Integrated Multiplexers and the customer line module of a local switch.

Declared Service

means, in the context of a ULLS, an eligible service declared by the ACCC under section 152AL of the *Trade Practices Act 1974* (Commonwealth).

Deployment Classes

means classes of systems which have been identified by industry as complying with the performance requirements specified under this Code when the systems are operated in accordance with the Deployment Rules associated with the particular Deployment Class. The Deployment Classes are contained in Part 3 of this Code.

NOTE: Clause 5.4 of Part 1 of this Code sets out the requirements for operation of systems that do not fall within a Deployment Class ('non-Deployment Class systems') contained in Part 3 of this Code.

Deployment Class System

means a system that corresponds to a Deployment Class contained in Part 3 of this Code.

Deployment Limit

means the maximum permitted Calculated Attenuation, at the reference frequency for the Deployment Class, from the Deployment Reference Point to the customer end of the ULLS Loop Trace.

Deployment Reference Point

means the point on the ULLS identified in accordance with Clause 4.6 of Part 1 of this Code.

Deployment Rule

means a constraint or prohibition or permission under this Code applying to the operation of systems belonging to a Deployment Class.

Deployment State A

means a particular categorisation of a DA in accordance with Clause 4.5 of Part 1 of this Code.

Deployment State B

means a particular categorisation of a DA in accordance with Clause 4.5 of Part 1 of this Code.

Distribution Area

means a designated sub-division of an Exchange Serving Area directly served by a single Lower CCF, or in the case of direct connection to the Upper CCF, the area directly served from the Upper CCF.

<p><i>NOTE: "Directly served" means that there is no other CCF between that Lower CCF and the NBP.</i></p>
--

Distribution Point

means the point where the lead in cable is connected to the distribution cable.

Disturbed System

means the system that is subject to crosstalk interference from a disturbing system.

Disturbing System

means the system that acts as the cause of crosstalk interference into a disturbed system.

Downstream

means the direction from the POI-ULLS to the NBP.

Equipment Connection Point

means the point where customer equipment connects to customer cabling which is connected to the ULLS at the NBP.

NOTE: Customer equipment may include multiple items (e.g. one or more telephone handsets associated with a customer's ADSL modem).

Exchange Serving Area

means the area served from a traditional local exchange building.

High Capacity Local Loop

means the end-to-end Communications Wire used for the delivery of Broadband services, including an interconnection cable at the POI, a ULLS between the POI and the NBP, and customer cabling to the ECP.

Highest CCF

means the CCF that is furthest from the NBP.

Highest NRP

means the location of the ULLS-NRPs at the Highest CCF that serves the DA.

Legacy Systems

means systems of a type which were present in the network before publication of this document.

Low band

means frequencies up to 20 kHz.

Lower CCF

means a CCF closer to the NBP than the Upper CCF, where there is continuity of Communications Wire between both CCFs.

Lower NRP

means the location of the ULLS-NRP at a CCF other than the Highest CCF that serves the DA.

NOTE: In relation to the transition to Deployment State B this may include a proposed Lower NRP.

Lowest Asymmetric System Feed Point

means the point on the ULLS identified in accordance with Clause 4.7 of Part 1 of this Code.

Network Boundary Point

means the boundary of a telecommunications network as determined in accordance with section 22 of the *Telecommunications Act 1997* (Commonwealth).

Nominated Lower NRP

is the Lower NRP that is nominated for the purposes of Deployment State B.

NOTE: The process for nominating this point is not addressed in this code (see Clause 4.5.6 of Part 1 of this Code). The definition of Deployment State B in Section 4 of Part 1 of this Code assumes the existence of a Nominated Lower NRP.

Non-Deployment Class System

means a system that is not a Deployment Class System.

Pair Separation

means the allocation of pairs of Communication Wires for two Deployment Classes:

- (a) into separate Cable Units in unit cable; or
- (b) with pair number differing by 10 or more in quad cable.

Party

means a participant in the section(s) of the telecommunications industry to which this Code applies.

Point of Interconnection with respect to the ULLS

means the point at which the tie cable joins the AS's IDF.

Power Feeding over the ULLS

means the practice of powering equipment remotely using the ULLS.

Remote Integrated Multiplexer

means one of a group of similar CAMs which may be located at a Lower CCF.

RFT-C circuit

means a current limited RFT circuit.

SDSL

means an older variable rate 2B1Q line coded system with similar characteristics to HDSL. From ACIF C559:2005 onwards the use of SDSL is deprecated in favour of alternative technologies with lower interference characteristics, such as G.SHDSL

Spectral Compatibility Benchmark

means the determined relationship for a Basis System between bit rates achievable in each direction and range (expressed as a single range for a fixed rate system) for an error rate of 10^{-7} with a margin of 6dB in the 1% worst case crosstalk environment.

NOTE: The 1% worse case crosstalk environment is defined in Clause 5 of Part 2 of this Code.

Spectral Compatibility Benchmark I

means a Spectral Compatibility Benchmark for a Basis System operating from either:

- (a) the highest NRP in Deployment State A; or
- (b) the nominated lower NRP in Deployment State B.

NOTE: Refer to Clause 4 of Part 2 of this Code for more information on the determination of Spectral Compatibility Benchmark I.

Spectral Compatibility Benchmark II

means a Spectral Compatibility Benchmark for a Basis System operating from the highest NRP in Deployment State B.

NOTE: Refer to Clause 4 of Part 2 of this Code for more information on the determination of Spectral Compatibility Benchmark II.

Spectral Compatibility Determination Process

means the process contained in Part 2 of this Code for determining spectral compatibility of systems operated using ULLS.

Spectral Compatibility Model

means the model developed by Communications Alliance for the purpose of determining whether or not the operation of a system will cause Unacceptable Interference into a Basis System.

Spectrally Asymmetric

means using different PSD for transmission in each direction.

Spectrally Symmetric

means using the same PSD for transmission in each direction.

Standard Telephone Service

has the meaning given by section 6 of the *Telecommunications (Consumer Protection and Service Standards) Act 1999 (Commonwealth)*.

Transitional Arrangements

are the technical and commercial terms and conditions under which ULLS will be provided during the transition between Deployment States A and B, which may include but are not limited to the nomination of a Nominated Lower NRP, notice and consultation periods, transmission and alternative service arrangements.

Trial System or Extraordinary and Temporary Use System

means a system that is operated in accordance with Clause 5.6 of Part 1 of this Code.

ULLS - End User Reference Point

means the customer end of the ULLS.

ULLS Loop Trace

means a list of all the lengths, types, gauges and dispositions of all the Communications Wire segments, both in line and Bridge Taps, pertaining to the ULLS.

ULLS - Network Reference Point

is the network end of the ULLS.

NOTE: For a system operated by an AS, the ULLS - NRP will be the point at which the tie cable from the AS's IDF joins to the AP's MDF. For a system operated by an AP, the ULLS - NRP will be the point at which the AP gains access to the ULLS for its own services.

Unacceptable Excess Power

has the meaning given in Clause 5.2.3 of Part 1 of this Code.

Unacceptable Interference into a Basis System

has the meaning given in Clause 5.2.2 of Part 1 of this Code.

Unconditioned Local Loop Service

means the use of unconditioned communications wire between the boundary of a telecommunications network at an end user's premises and a point on a telecommunications network that is a potential point of interconnection located at or associated with a CAM and located on the end user side of the CAM.

xDSL

refers to different variations of a family of Digital Subscriber Line (DSL) technologies, such as ADSL, ADSL2+, HDSL, SHDSL, VDSL and similar technologies that provide a high bandwidth digital connection over Communications Wire.

2.3 Interpretations

In the Code, unless the contrary appears:

- (a) headings are for convenience only and do not affect interpretation;
- (b) a reference to a statute, ordinance, code or other law includes regulations and other instruments under it and consolidations, amendments, re-enactments or replacements of any of them;
- (c) words in the singular includes the plural and vice versa;
- (d) words importing persons include a body whether corporate, politic or otherwise;

- (e) where a word or phrase is defined, its other grammatical forms have a corresponding meaning;
- (f) mentioning anything after include, includes or including does not limit what else might be included;
- (g) words and expressions which are not defined have the meanings given to them in the Act; and
- (h) a reference to a person includes a reference to the person's executors, administrators, successors, agents, assignees and novatees.

3 BILATERAL AGREEMENTS

- 3.1. This Code sets minimum acceptable practices. This Code does not limit industry's ability to improve on these minimum acceptable practices.
- 3.2. This Code does not constrain two or more parties from agreeing to different arrangements provided that those arrangements meet the minimum levels prescribed in this Code.
- 3.3. Parties to this Code recognise that they will enter into bilateral agreements regarding the provision of the ULLS, which may include but are not limited to the following matters:
 - (a) indemnities and limitations of liability;
 - (b) operational arrangements;
 - (c) location of the POI-ULLS;
 - (d) disclosure of information about the AP's network;
 - (e) exceptional circumstances;
 - (f) electromagnetic compatibility;
 - (g) electrical safety standards; and
 - (h) surge protection.

4 REFERENCE ARCHITECTURE FOR SERVICES USING THE ULLS

4.1 Background

4.1.1 An AS wanting to offer services to its customers using an ULLS will need to establish a POI-ULLS with the AP in the area to be served. Following the provisioning of a ULLS from the POI-ULLS to the customer premises by the AP, the AS will need to ensure that customer cabling is provided between the NBP and the ECP in order to provide an end-to-end service.

4.1.2 This Code recognises that POI-ULLSs can only be established in a limited set of locations for any given Exchange Serving Area within the local loop. Figure 4-1 below shows the simplest case of an end-to-end service operating from a single POI-ULLS located at the local exchange. In Figure 4-1 the Lower CCFs are shown as potential POI-ULLSs.

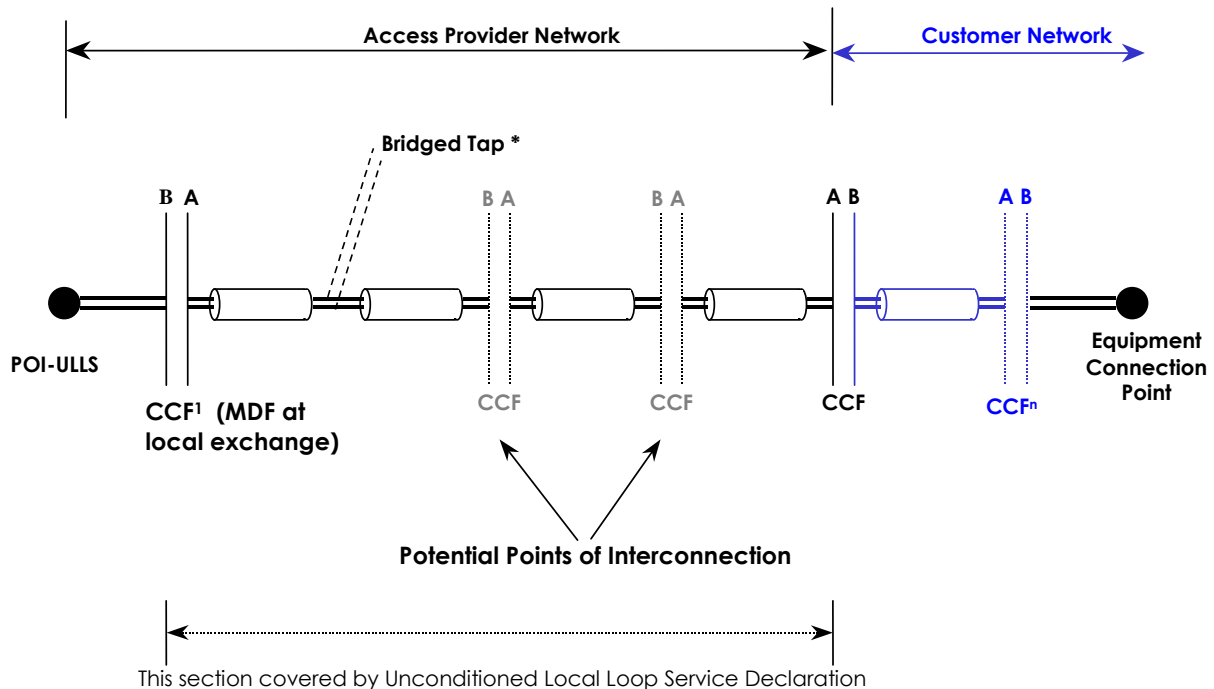

* Note: Bridged taps could be located at multiple points

Figure 4-1

Schematic Diagram of an End-to-End Service Using the ULLS

- 4.1.3 Each CCF may feed multiple CCFs, and may be fed from multiple CCFs.
- 4.1.4 Each Communications Wire may also branch at any point into two (or more) Communications Wires, thus forming a 'bridged tap' when one of the branches is used to provide a ULLS.
- 4.1.5 The reference architecture caters for different services and different service types with different POI-ULLSs. The ability to describe and distinguish between different POI-ULLSs for services carried by pairs

within the same Cable Unit is necessary for the development of spectral compatibility guidelines.

- 4.1.6 The Communications Wire used to provide the ULLS may be made up of multiple sections of cables of different types between the Highest CCF and the NBP. Each section may be of a different cable type (i.e. conductor, insulation, and/or sheath material may differ) as well as conductor gauge and pair arrangement (i.e. layered, paired, quad, etc.). The cable pair count may also differ.

4.2 ULLS Reference Architecture

Figure 4-2 below shows a schematic diagram of the ULLS Reference Architecture.

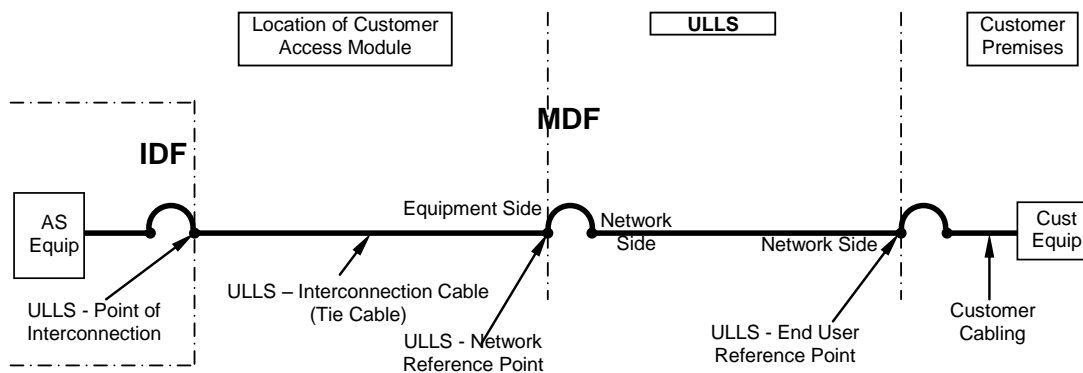

Figure 4-2

Schematic Diagram of the ULLS Reference Architecture

4.3 Single and Multiple Feed Distribution Areas

- 4.3.1 The local loop environment is made up of multiple DAs within an ESA. Traditionally, a combination of main, branch and distribution cable connected the local exchange to each DA, and distribution cable used within each DA, as shown in Figure 4-3.

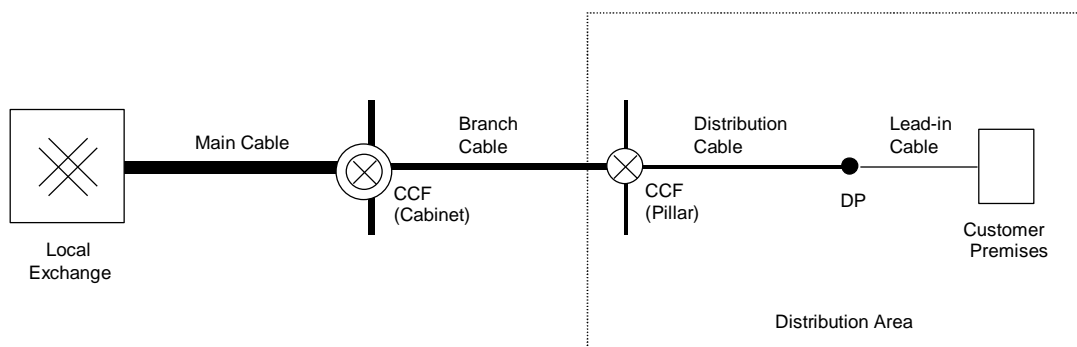

Figure 4-3

Schematic Diagram of the Traditional Local Loop

- 4.3.2 The trend over the last decade has been to connect new DAs to the network by optical fibre instead of using main cable, and to augment shortages of main cable to existing DAs with optical fibre. Any particular DA may be fed from either ULLS-NRPs at a single location (single feed) or from ULLS-NRPs at more than one location (multiple feed).

- 4.3.3 Single feed applies where systems in a particular DA are fed from ULLS-NRPs at a single location. This may be at the MDF of the local exchange in the case of a DA connected by main and/or branch cable, or at a CCF associated with a kerbside facility such as a RIM where the DA is connected by optic fibre. Two examples of single feed DAs are shown in Figures 4-4 and 4-5.

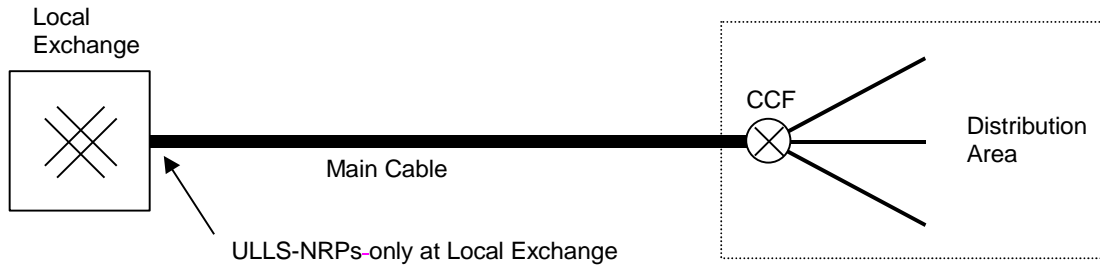

Figure 4-4

Example 1: Single Feed DA with ULLS-NRPs at the Local Exchange

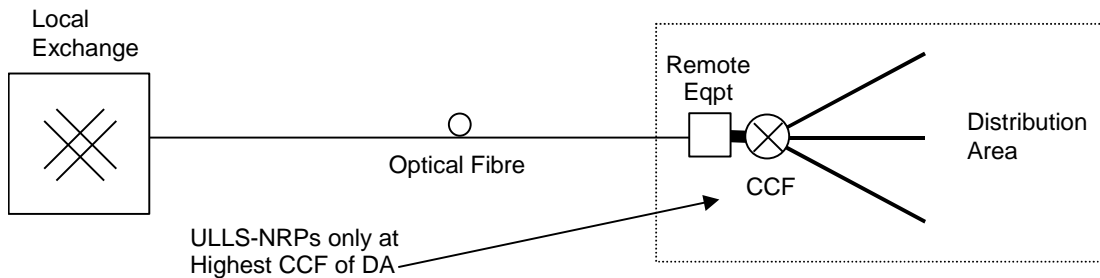

Figure 4-5

Example 2: Single Feed DA with ULLS-NRPs at a RIM

- 4.3.4 Multiple feed applies where systems in a particular DA are fed from ULLS-NRPs at more than one location. The Highest NRP is located at the Highest CCF (e.g. at the local exchange) and Lower NRPs are located at Lower CCFs (e.g. at a RIM). Figure 4-6 shows an example of multiple feed, where ULLS-NRPs at two locations serve a DA.

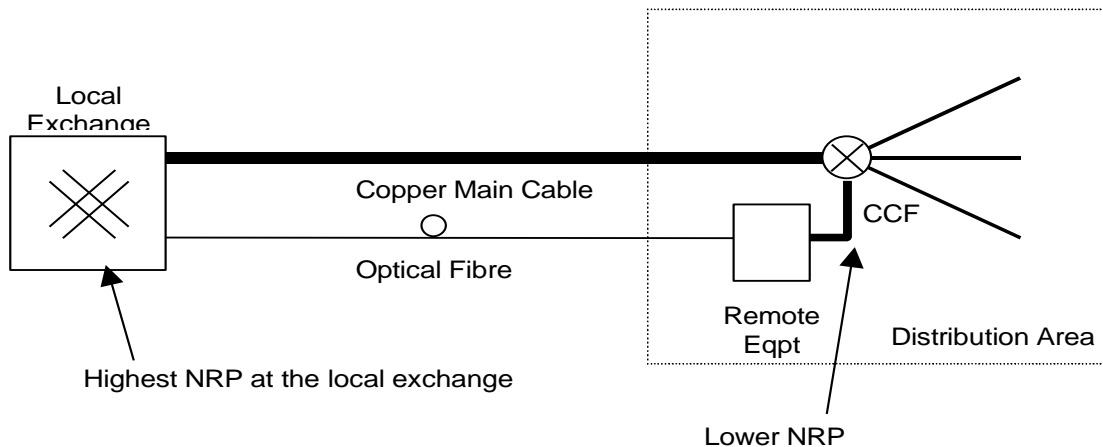

Figure 4-6

Example 3: Multiple Feed: ULLS-NRPs at two locations serving a single DA

4.4 Performance Implications of Single and Multiple Feed DAs

- 4.4.1 For the single feed DA, all systems operating in that DA are fed from the Highest NRP. In this network case, problems with differing transmit levels on adjacent communications wires are avoided.
- 4.4.2 In contrast, for the multiple feed DA:
 - (a) there is potential for unequal level crosstalk interference from Spectrally Asymmetric Systems fed from Lower NRPs to degrade the performance of Spectrally Asymmetric Systems fed from the Highest NRP;
 - (b) Spectrally Symmetric Systems fed from the Highest NRP are not expected to be degraded by crosstalk interference from any systems fed from Lower NRPs.

4.5 Deployment States A and B

- 4.5.1 This Code categorises every DA as being in either Deployment State A or Deployment State B. The categorisation of a DA as Deployment State A or Deployment State B is relevant for determining Spectral Compatibility Benchmarks for Basis Systems.

NOTE: See Clause 5.2.2 of Part 1 of this Code which provides the performance requirements for the particular Deployment State.

- 4.5.2 A Single Feed DA is always in Deployment State A. A Multiple Feed DA may be in Deployment State A or Deployment State B.
- 4.5.3 A DA is in Deployment State A unless it is in Deployment State B.
- 4.5.4 Deployment State A is the default state for all DAs.
- 4.5.5 A DA is in Deployment State B where a particular Lower NRP is nominated for the DA, viz. the Nominated Lower NRP. The Nominated Lower NRP is the Lowest Asymmetric System Feed Point in Clause 4.7.3 of Part 1 of this Code.

4.5.6 The process for nominating the Nominated Lower NRP and the transition to Deployment State B is not addressed in this Code. It is the intention of Carriers and Carriage Service Providers that:

- (a) the process for nominating the Nominated Lower NRP and the Transitional Arrangements be addressed as part of bilateral agreements with the AP; and
- (b) the Transitional Arrangements be completed before Deployment State B takes effect for a particular DA.

4.6 Deployment Reference Points

4.6.1 For a system operated in a DA that is in Deployment State A, the Deployment Reference Point is:

- (a) for a Deployment Class System, at the Highest NRP;
- (b) for a Non-Deployment Class System, the reference point nominated by the carrier or carriage service provider under Clause 5.4.4 of Part 1 of this Code.

4.6.2 For a system operated using the ULLS in a DA that is in Deployment State B, the Deployment Reference Point is:

- (a) for a Deployment Class System, the Deployment Reference Point corresponding to the applicable Deployment Class;
- (b) for a Non-Deployment Class System, the reference point nominated by the carrier or carriage service provider under Clause 5.4.4 of Part 1 of this Code.

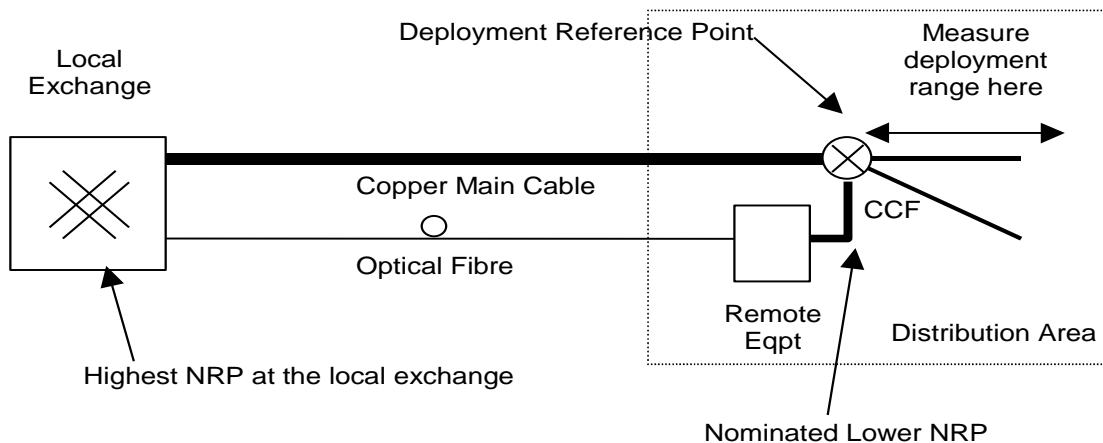

Figure 4-7

One possible location of Deployment Reference Point at Nominated Lower NRP in Deployment State B.

4.7 Lowest Asymmetric System Feed Point

4.7.1 The Lowest Asymmetric System Feed Point is the lowest point from which a Spectrally Asymmetric System may be fed.

NOTE: Feeding any Spectrally Asymmetric System from a lower point causes Unacceptable Interference into a Basis System.

- 4.7.2 For a system operated in a DA that is in Deployment State A, the Lowest Asymmetric System Feed Point is:
- (a) for a Deployment Class System, at the Highest NRP;
 - (b) for a Non-Deployment Class System, the reference point nominated by the carrier or carriage service provider under Clause 5.4.4 of Part 1 of this Code.
- 4.7.3 For a system operated using the ULLS in a DA that is in Deployment State B, the Lowest Asymmetric System Feed Point is:
- (a) for a Deployment Class System, the Nominated Lower NRP;
 - (b) for a Non-Deployment Class System, the reference point nominated by the carrier or carriage service provider under Clause 5.4.4 of Part 1 of this Code.

5 PERFORMANCE REQUIREMENTS FOR OPERATION OF SYSTEMS USING THE ULLS

5.1 General

- 5.1.1 Clause 8 of Part 1 of this Code imposes performance requirements on systems operating on the ULLS in order to:
- (a) control interference into systems carried in the same cable sheath where the disturbed system is of the same type as a Basis System; and;
 - (b) maximise the efficient use of the ULLS spectrum.
- 5.1.2 Management of interference between systems operated using the ULLS is affected by a number of characteristics of the systems. The characteristics that have been identified in the development of this Code include:
- (a) transmit PSD;
 - (b) total average (transmit) power;
 - (c) longitudinal output voltage;
 - (d) longitudinal balance; and
 - (e) deployment range.
- 5.1.3 The concepts of Unacceptable Interference into a Basis System and Unacceptable Excess Power are used in this Code as the basis for the obligations on carriers and carriage service providers operating systems using the ULLS. These concepts are based on the Spectral Compatibility Determination Process described in Part 2 of this Code. It should be noted that ensuring that a system does not cause Unacceptable Interference into a Basis System does not guarantee a level of performance for any deployed system.

NOTES:

1. Limiting Unacceptable Interference into a Basis System ensures that all Basis System types have an error rate less than 1 in 10^{-7} in the 1% worst case crosstalk environment. Basis Systems are idealised systems that correspond to several particular system types that are operated using the ULLS.

2. Limiting Unacceptable Excess Power avoids the use of spectrum prior to the consideration by industry of the most efficient use of that spectrum in the operation of systems using the ULLS.

- 5.1.4 To facilitate the deployment and operation of systems using the ULLS, industry has developed Deployment Classes and associated Deployment Rules that, if complied with, ensure that the requirements of this Code are met.
- 5.1.5 This Code provides for separate processes for determining compliance with the Code in relation to operation of systems:

- (a) that correspond to a Deployment Class contained in Part 3 of this Code ('Deployment Class Systems'); and
- (b) that do not correspond to a Deployment Class ('Non-Deployment Class Systems').

NOTE: These processes are set out in Clauses 8.3 and 8.4 of Part 1 of this Code respectively.

- 5.1.6 The Deployment Classes contained in Part 3 of this Code address, *inter alia*, the characteristics listed in Clause 8.1.2 of Part 1 of this Code in order to avoid Unacceptable Interference into a Basis System from systems that are within a Deployment Class.

NOTE: See Clause 8.3 of Part 1 of this Code.

- 5.1.7 The effect of the Deployment Classes in determining Unacceptable Interference into a Basis System and Unacceptable Excess Power is dependent on the customer equipment being used in connection with the carrier or carriage service provider's system meeting the requirements of the corresponding equipment class set out in AS/ACIF S043.2.

NOTE: Clause 8.3.2 of Part 1 of this Code provides that a system is taken to be complying with the requirements of a Deployment Class only if the customer equipment used in connection with the system meets the requirements of the corresponding equipment class.

- 5.1.8 In order to demonstrate that the operation of Non-Deployment Class Systems meet the requirements of this Code, a carrier or carriage service provider that proposes to operate a Non-Deployment Class System must use the Spectral Compatibility Determination Process as contained in Part 2 of this Code to demonstrate that both Unacceptable Interference into a Basis System and Unacceptable Excess Power do not occur.

NOTE: See Clause 5.4 of Part 1 of this Code.

5.2 Rules for Operation of Systems using the ULLS

- 5.2.1 A carrier or carriage service provider must not operate a system using the ULLS if the system causes:
- (a) Unacceptable Interference into a Basis System; or
 - (b) Unacceptable Excess Power.

NOTES:

- 1. Clause 5.2.1 of Part 1 of this Code applies to both Deployment Class Systems and Non-Deployment Class Systems.*
- 2. Clause 5.2.2 of Part 1 of this Code provides that the assessment of whether a system operated using ULLS causes Unacceptable Interference into a Basis System is dependent on whether the disturbing system is being operated in a DA that is either in Deployment State A or Deployment State B.*

3. For Deployment Class Systems, Clause 8.3 of Part 1 of this Code provides the only means of ensuring compliance with the obligation in 5.2.1 of Part 1 of this Code.

4. For Non-Deployment Class Systems, Clause 8.4 of Part 1 of this Code provides the only means of ensuring compliance with the obligation in 5.2.1 of Part 1 of this Code.

5. Section 6 of Part 1 of this Code prohibits a person from operating a system if the system uses power feeding equipment that does not comply with certain safety requirements.

5.2.2 For the purposes of Clause 5.2.1(a) of Part 1 of this Code a system ('the disturbing system') causes Unacceptable Interference into a Basis System if:

- (a) for a system that is operated in a DA that is in Deployment State A, the disturbing system causes crosstalk interference that degrades the performance of any Basis System fed from the Highest NRP below its Spectral Compatibility Benchmark I as specified in Clause 4.1.1 of Part 2 of this Code; or
- (b) for a system that is operated in a DA that is in Deployment State B, the disturbing system causes crosstalk interference that degrades the performance of:
 - (i) any Spectrally Asymmetric Basis System fed from the Highest NRP below its Spectral Compatibility Benchmark II as specified in Clause 4.2.1 of Part 2 of this Code; or
 - (ii) any Basis System fed from the Nominated Lower NRP below its Spectral Compatibility Benchmark I as specified in Clause 4.1.1 of Part 2 of this Code.

NOTE: Clause 2.3 of Part 2 of this Code defines the configurations and conditions under which Unacceptable Interference into a Basis System is determined.

5.2.3 For the purposes of Clause 5.2.1(b) of Part 1 of this Code a system causes Unacceptable Excess Power if the system transmit PSD does not satisfy the requirements of Clause 2.4 of Part 2 of this Code.

NOTE: Clause 5.4.5(b) of Part 1 of this Code provides that, for a Non-Deployment Class System, a carrier or carriage service provider must use the maximum transmit PSD mask (at the ULLS-NRP and ULLS-EURP) supplied to the Access Provider to determine whether the system causes Unacceptable Excess Power. Clause 2.4 of Part 2 of this Code sets out the requirements in respect of Unacceptable Excess Power.

5.3 Operation of Deployment Class Systems

5.3.1 Clause 5.3 of Part 1 of this Code provides the only means of demonstrating compliance with the obligation in Clause 5.2.1 of Part 1 of this Code for a Deployment Class System.

NOTE: Part 3 of this Code lists Deployment Classes and indicative technologies that correspond to those Classes. The Deployment

Classes are grouped according to indicative technologies (e.g. E1 HDB3, ISDN BR 2B1Q, ADSL, ADSL over ISDN, SHDSL).

- 5.3.2 A carrier or carriage service provider that operates a Deployment Class System must meet each of the following conditions in order to comply with Clause 5.2.1 of Part 1 of this Code:
- (a) the operation of the network equipment is in accordance with the requirements of the applicable Deployment Class;
 - (b) the operation of the customer equipment is in accordance with the requirements of the Equipment Class in AS/ACIF S043.2 that corresponds to the applicable Deployment Class; and
 - (c) the operation of the system is in accordance with the Deployment Rules for the applicable Deployment Class set out in Part 3 of this Code.

NOTE: Appendix A to Part 1 of this Code shows the method of complying with the Deployment Limit requirements applicable to Deployment Classes.

5.4 Operation of Non-Deployment Class Systems

- 5.4.1 Clause 8.4 of Part 1 of this Code provides the only means of complying with the obligation in Clause 8.2.1 of Part 1 of this Code for a Non-Deployment Class System.
- 5.4.2 In determining whether the operation of a Non-Deployment Class System causes Unacceptable Interference into a Basis System a carrier or carriage service provider must:
- (a) use the Spectral Compatibility Determination Process; and
 - (b) use the Spectral Compatibility Model.

NOTE: The Spectral Compatibility Determination Process and the ACIF Spectral Compatibility Model are contained in Part 2 of this Code.

- 5.4.3 A carrier or carriage service provider must not operate a Non-Deployment Class System using the ULLS if:
- (a) the parameters specified in Clause 5.4.4 of Part 1 of this Code have not been provided to the Access Provider and Communications Alliance ; or
 - (b) the operation of the system causes any of the masks, values or limits supplied to the Access Provider and Communications Alliance under Clauses 5.4.4(a), (b), (c) and (f) of Part 1 of this Code to be exceeded; or
 - (c) the ULLS does not have the required pair separation notified to the Access Provider and Communications Alliance under Clause 5.4.4(d) of Part 1 of this Code; or
 - (d) the system equipment longitudinal output voltage exceeds the mask supplied to the Access Provider and Communications Alliance under Clauses 5.4.4(g) of Part 1 of this Code, or the longitudinal balance is below the mask supplied to the Access

Provider and Communications Alliance under Clause 5.4.4(h) of Part 1 of this Code; or

- (e) the system transmit PSD does not satisfy the requirements of Clause 2.4 of Part 2 of this Code.

NOTES:

1. Pair separation may be required to ensure that the operation of a system does not cause Unacceptable Interference into a Basis System. In this case, the requirement for pair separation arises as a result of using the process described in Part 2 of this Code.

2. Where a proposed system would be utilising spectrum outside of the existing Basis Systems the carrier or carriage service provider proposing to operate the system may approach Communications Alliance to request a review of this Code to allow the industry to consider the most efficient use of spectrum by the system.

3. Clause 5.4.4 of Part 1 of this Code sets out the information required for determining whether a Non-Deployment Class System will cause Unacceptable Interference to a Basis System.

5.4.4 For the purpose of Clause 5.4.3 of Part 1 of this Code, the details that must be provided to the Access Provider and Communications Alliance are:

(a) either:

(i) maximum transmit PSD masks at the ULLS-NRP and the ULLS-EURP; or

(ii) for a Non-Deployment Class System that complies with all Group B requirements of a nominated Deployment Class and has the Group B mask replaced by a linearly filtered version of itself:

i. the nominated Deployment Class; and

ii. the amount of filter attenuation in dB by which the Group B PSD mask exceeds the filtered mask at each of the ULLS-NRP and the ULLS-EURP;

(b) maximum total average power at the ULLS-NRP and the ULLS-EURP;

NOTE: Transmit PSD masks and average power may include power cut back specification.

(c) proposed maximum Deployment Limit from the Deployment Reference Point specified in Clause 5.4.4(e) and reference frequency;

(d) proposed pair separation at the network end from Deployment Class 1(b) systems; and

NOTE: See Clause 5.4.3(c) of Part 1 of this Code above.

- (e) if the Deployment Reference Point for the proposed system is not the Highest NRP, the proposed locations of Deployment Reference Points for operation of the system in Deployment State A and Deployment State B;

NOTE: Each Deployment Reference Point needs to be specified relative to either the Highest NRP or the Nominated Lower NRP. If the information is not supplied, the DRP will default to the Highest NRP.

- (f) if the proposed system is a Spectrally Asymmetric System, the Lowest Asymmetric System Feed Point from which the carrier or carriage service provider proposes to feed the system in each of Deployment State A and Deployment State B.

NOTE: The points referred to in (f) need to be specified relative to either the Highest NRP or the Nominated Lower NRP. For example, either at one of these locations or at a specified calculated attenuation therefrom. If the information is not supplied, the Lowest Asymmetric System Feed Point defaults to the Highest NRP in Deployment State A and the Nominated Lower NRP in Deployment State B.

- (g) maximum longitudinal output voltage masks for network equipment and customer equipment;
- (h) minimum longitudinal balance masks for network equipment and customer equipment.

NOTES:

1. The details referred to in (1) through to (8) are intended to correlate with information used in the definition of Deployment Classes.
2. Clause 8.4.3 of Part 1 of this Code provides that the operation of a Deployment Class system must not exceed any of the masks, values or limits supplied under Clause 5.4.4 of Part 1 of this Code.
3. The determination of compliance with Deployment Limits for Non-Deployment Class Systems uses the same method as for Deployment Class Systems in Appendix A.
4. For a Non-Deployment Class System with specified filter attenuation as described by 5.4.4(a)(ii) of Part 1 of this Code, it may be sufficient to reference the relevant requirement of the nominated Deployment Class for any of 5.4.4(b) to (h) of Part 1 of this Code that is already compliant.

5.4.5 For the purposes of Clause 5.4.4 of Part 1 of this Code:

- (a) the parameters supplied under Clause 5.4.4 of Part 1 of this Code must be the parameters used in or derived as a result of using Clause 2.3 of Part 2 of this Code to determine whether the system causes Unacceptable Interference into a Basis System. For a Non-Deployment Class System with specified filter attenuation as described by Clause 5.4.4(a)(ii) of Part 1 of this Code, the filter attenuation shall be subtracted from the relevant Group A requirement for the specified Deployment Class to provide a modified crosstalk calculation template; and

NOTE: Group A requirements for a Deployment Class are listed in the relevant Appendix to Part 3 of this Code or the relevant Appendix to AS/ACIF S043.2. Refer to Table A-1 in Appendix A of Part 3 of this Code for a table of Deployment Classes.

- (b) the masks referred to in Clause 5.4.4(a) of Part 1 of this Code must be used in the test contained in Clause 2.4 of Part 2 of this Code to determine that the system does not cause Unacceptable Excess Power.

NOTE: Clause 5.2.1(b) of Part 1 of this Code prohibits a person from operating a system if the system causes Unacceptable Excess Power.

5.5 Use of More Than One System Type on a single ULLS

- 5.5.1 This Clause sets out the compliance requirements where a carrier or carriage service provider is operating more than one system type using a single ULLS.
- 5.5.2 Where a carrier or carriage service provider is operating more than one system type on a single ULLS and the system types operate only in separate time intervals then the operation of each system must comply with Clause 8.2 of Part 1 of this Code.

NOTE: This case is expected to arise where line test equipment is used on a ULLS.

- 5.5.3 Where a carrier or carriage service provider is operating more than one system type on a single ULLS and the systems do not operate in separate time intervals:
 - (a) the systems constitute a composite system that corresponds to a Non-Deployment Class System; and
 - (b) the operation of the composite system must comply with Clauses 5.2 and 5.4 of Part 1 of this Code.

5.6 Trials and Extraordinary or Temporary uses

- 5.6.1 For the purposes of Clause 1.3.6 of Part 1 of this Code, a Trial System or Extraordinary and Temporary Use System is a system that meets each of the requirements of Clause 5.6.2 of Part 1 of this Code.

NOTE: Clause 1.3.6 provides that the operation of a Trial or Extraordinary and Temporary Use that meets the requirements of Clause 5.6.2 of Part 1 of this Code is not subject to the obligations in Clause 5.2.1 of Part 1 of this Code.

- 5.6.2 A system is a Trial System or Extraordinary and Temporary Use System if the operation of the system meets each of the following conditions:
 - (a) the Access Provider believes on reasonable grounds that the Trial or Use does not:
 - (i) compromise the integrity of a telecommunications network or facility; or

- (ii) compromise the health or safety of persons operating, working on, using or otherwise likely to be affected by the operation of a telecommunications network or facility;
- (b) where the operation of the system will cause Unacceptable Interference into a Basis System or Unacceptable Excess Power, each affected party has given consent to the operation of the system; and
- (c) where the use is extraordinary or temporary (but not a trial):
 - (i) the use does not exceed 30 days; or
 - (ii) each affected party has given consent to a use that will exceed 30 days.

NOTES:

1. In practice, use of the above trial or extraordinary or temporary use provisions set out above will only be necessary where the operation of the system would otherwise breach Clause 8.2 of Part 1 of this Code.

2. Consent to an extraordinary or temporary use that will exceed 30 days may be given prior to or during the use.

- 5.6.3 For the purposes of 5.6.2 of Part 1 of this Code an affected party is a carrier or carriage service provider that is operating or proposing to operate a Compliant System carried in the same cable sheath as the proposed Trial System or Extraordinary and Temporary Use System.

6 POWER FEEDING OF REMOTE EQUIPMENT USING THE ULLS

6.1 Overview

- 6.1.1 This clause prescribes safety requirements that apply where a carrier or carriage service provider operates a system that uses power feeding for remote equipment connected to the ULLS.
- 6.1.2 A carrier or carriage service provider must take reasonable steps to ensure that power feeding arrangements do not endanger the health or safety of persons that install, operate or maintain or otherwise come into contact with the ULLS and any derived carriage service.

NOTE: Clause 6.3.5 of Part 1 of this Code provides that a carrier or carriage service provider is taken to comply with clause 6.1.2 of Part 1 of this Code if the power feeding arrangements comply with the requirements set out in sub-clauses (a) to (e) of clause 6.3.5 of Part 1 of this Code.

6.2 General Requirements of Power Feeding Equipment connected to ULLS

- 6.2.1 A carrier or carriage service provider must not operate a system with a remote power feeding capability unless:
- (a) the power feeding voltage does not exceed the TNV-3 limits of AS/NZS 60950.1; or
 - (b) if the system exceeds the TNV-3 limits of AS/NZS 60950.1, the system meets each of the following requirements:
 - (i) only d.c. power feeding must be used;
 - (ii) the maximum voltage between communications wires and from each communications wire to earth, must not exceed 300 Volts d.c.;
 - (i) either:
 - i. the requirements of ITU-T Recommendation K.50 "Safe limits of operating voltages and currents for telecommunication systems powered over the network" for RFT-C circuits (RFT-V circuits are not allowed); or
 - ii. the system has the following characteristics:
 - (A) current limiting must be used;
 - (B) the steady-state power feed current must not exceed 50 mA d.c. for earthed systems or 60 mA d.c., if the resistance to earth of the power feed system is greater than 50 k Ω ;
 - (C) the operate-time for current limiting must be less than 10 milliseconds; and

- (D) the product of the maximum voltage at the point of contact and the effective capacitance at the point of contact must not exceed 0.01 Volt Farads for earthed power feed systems or 0.025 Volt Farads if the resistance to earth of the power feed system is greater than 50 k Ω . The effective capacitance at the point of contact is the capacitance of the total system, which includes the communications wires and the power feeding equipment and power fed equipment.

6.3 Safety Requirements for Power Feeding into Customer Premises

- 6.3.1 All equipment should be installed and maintained in a manner to minimise the likelihood of unintentional contact by service personnel or bridging of bare power feeding parts.
- 6.3.2 A general principle of double-insulation and warning labels should be adopted to prevent end-user contact with power feed circuits that exceed the limits of TNV.
- 6.3.3 Where possible, exclusive carrier or carriage service provider cabling should be used to bypass customer-cabling distributors and restrict access to power feeding line conductors.
- 6.3.4 RFT line conductors used to extend power feed circuits into the customer premises should terminate directly on the power feeding or power fed equipment. Under no circumstances shall connectors (i.e. 4, 6 or 8-way modular connectors) that are used to connect customer equipment be used to connect power feed circuits.
- 6.3.5 When the power feeding voltage exceeds TNV-3, (i.e. 120 Volts d.c.), a carrier or carriage service provider is taken to comply with Clause 6.1.2 of Part 1 of this Code, if each of the following requirements is met:
 - (a) RFT circuits must not share a common cable sheath with customer cabling.
 - (b) ULLS cable termination facilities must be separated from SELV and TNV building cabling by a distance of at least 150 mm or by a barrier which is rigidly fixed and made of a durable insulating material. Any guard or barrier should be easily removable and replaceable if access is necessary for servicing.
 - (c) Customer cabling jumpers or patch cords must not be used to carry RFT circuits. Conductors used to carry RFT circuits must be double insulated and must not share customer cabling termination modules that form part of the common building/campus cabling system.
 - (d) All accessible cable termination points and barriers must be labelled 'Warning: Power Feeding' and display the carrier or carriage service provider name or logo.
 - (e) All customer-premises cabling records must describe the pair usage as 'Warning: Power Feeding Telecommunications'.

7 COMPLIANCE WITH PERFORMANCE REQUIREMENTS UNDER THIS CODE

7.1 Overview

The AS and the AP have complementary roles in complying with this Code. This clause sets out recommended methods that each party may use to demonstrate compliance.

7.2 Responsibility for Compliance

- 7.2.1 It is the responsibility of the AS to specify the required Deployment Class and to ensure that the system operated on the ULLS always complies with all of the requirements for belonging to that Deployment Class.

NOTE: Where this and subsequent clauses refer to Deployment Class System specification and rules, the specification of a Non-Deployment Class System with associated parameters and rules is also permitted.

- 7.2.2 Upon receiving the request for a ULLS for a specified Deployment Class, it is the responsibility of the AP to perform a desktop study based on available records to ensure that the ULLS allocated for the service is within any Deployment Limit specified for that Deployment Class, and meets any Pair Separation requirements for that Deployment Class.

7.3 Compliance with Deployment Class Requirements

There are three alternative ways by which compliance may be demonstrated in order to confirm that a system is being operated in accordance with the requirements of a Deployment Class. These ways are:

- (a) certified compliance with a listed international standard; or
- (b) laboratory compliance of systems; or
- (c) operational compliance of systems.

7.4 Standards Compliance

Certified compliance with an international standard is acceptable. The system must comply with the international standard listed under Group B requirements for that Deployment Class in the relevant Appendix of Part 3 of this Code or in AS/ACIF S043.2 and the selection of the relevant options from that standard which are specified for that Deployment Class.

7.5 Laboratory Compliance

- 7.5.1 Laboratory compliance refers to compliance of a system when tested under laboratory conditions. To ensure that the system continues to comply at the ULLS-NRP in operation (as required by this Code), the AS must ensure that any allowances made for tie cables and for

variations between systems and with temperature are correctly accounted for.

- 7.5.2 For laboratory compliance, measurements must be conducted in a controlled environment in accordance with Appendix B of Part 1 of this Code.

7.6 Operational Compliance

- 7.6.1 Operational compliance refers to compliance when the system is operated on the ULLS. Because this is specified at the ULLS-NRP to which only the AP has access, it will only be tested by the AP.
- 7.6.2 For Deployment Class Systems operating on a ULLS qualified by the AP to meet Deployment Limits and Pair Separation requirements, the AS must operate the specified Deployment Class system in accordance with the requirements for the applicable Deployment Class.
- 7.6.3 To demonstrate that the correct Deployment Class is being used, measurements may be made on an operational service on the ULLS and without interruption as described in Appendix B of Part 1 of this Code.

8 OPERATION OF SYSTEMS IN CUSTOMER PREMISES (INFORMATIVE)

- 8.1.1 Systems that are not operated using the ULLS, but share customer cabling with systems operated using the ULLS may cause excessive crosstalk.
- 8.1.2 It is therefore recommended that all non-ULLS installations of Broadband systems (including LANs and all Deployment Classes other than 3a and 4a) should be kept in separate cable sheaths from ULLS systems.
- 8.1.3 However, if sharing occurs it is recommended that those non-ULLS broadband systems should be installed in the shared cable according to the Deployment Rules for ULLS systems, based on the relevant Deployment Reference Point and Lowest Asymmetric System Feed Point within the access network. Hence the following Deployment Rules are recommended in shared cable within the customer premises:
- (a) Systems belonging to Spectrally Asymmetric Deployment Classes or LAN systems should not be deployed in shared cabling; and
 - (b) Systems belonging to Spectrally Symmetric Deployment Classes should only be used in shared cabling if the total attenuation from the Deployment Reference Point in the access loop to the most distant point in the customer premise is less than the Deployment Limit for that Deployment Class.

9 CONDUCT OF EMPLOYEES, AGENTS, CONTRACTORS AND DEALERS

- 9.1.1 Each carrier or carriage service provider must use reasonable efforts to achieve compliance by its employees, agents, contractors and dealers with the provisions of this Code.
- 9.1.2 Each carrier or carriage service provider must undertake reasonable measures to develop a culture of compliance with this Code in its employees, agents, contractors and dealers.
- 9.1.3 If a carrier or carriage service provider becomes aware of any activities which are in contravention of this Code by its employees in the course of their employment or by its agents, contractors or dealers in the course of performing their functions as agents, contractors or dealers, the AS or AP, as the case may be, must take such action which may be reasonably available to it to prevent or discourage continuation of the breach of this Code.

10 REFERENCES

Publication	Title
Australian Standards	
AS/NZS 60950.1:2011	Information Technology Equipment - Safety - General Requirements http://infostore.saiglobal.com/Store2/Details.aspx?productID=1448798
Australian/Communications Alliance Standards	
AS/CA S002:2010	Analogue interworking and non-interference requirements for Customer Equipment for connection to the Public Switched Telephone Network http://commsalliance.com.au/Documents/all/Standards/s002
AS/CA S003	Customer Access Equipment for connection to a Telecommunications Network
AS/CA S003.1:2010	Part 1: General http://commsalliance.com.au/Documents/all/Standards/s003.1
AS/CA S003.2:2010	Part 2: Analogue and TDM based technologies http://commsalliance.com.au/Documents/all/Standards/s003.2
AS/ACIF S003.3:2010	Part 3: Packet and cell based technologies http://commsalliance.com.au/Documents/all/Standards/s003.3
AS/ACIF S006:2008	Requirements for Customer Equipment, operating in the voice band, for connection to the non-switched Telecommunications Network http://commsalliance.com.au/Documents/all/Standards/s006
AS/CA S008:2010	Requirements for authorised cabling products http://commsalliance.com.au/Documents/all/Standards/s008
AS/ACIF S009:2006	Installation requirements for customer cabling (Wiring Rules) http://commsalliance.com.au/Documents/all/Standards/s009
AS/ACIF S043	Requirements for Customer Equipment for connection to a metallic local loop interface of a Telecommunications Network
AS/ACIF S043.1:2003	Part 1: General http://commsalliance.com.au/Documents/all/Standards/s043.1
AS/ACIF S043.2:2008	Part 2: Broadband http://commsalliance.com.au/Documents/all/Standards/s043.2
AS/ACIF S043.3:2008	Part 3: DC, low frequency AC and voiceband http://commsalliance.com.au/Documents/all/Standards/s043.3

Industry Codes

ACIF C569:2005	Ordering, Provisioning And Customer Transfer For ULL Services Industry Code http://commsalliance.com.au/Documents/all/codes/c569
-------------------	--

Industry Guidelines

ACIF G563:2001	Supporting arrangements for the supply of Digital Subscriber Line (DSL) Customer Equipment http://commsalliance.com.au/Documents/all/guidelines/g563
-------------------	---

G572:2007	Unconditioned Local Loop Service Fault Management Industry Guideline http://commsalliance.com.au/Documents/all/guidelines/g572
-----------	---

ACIF G618:2004	Approval of Non-Deployment Class Systems under ACIF C559 Industry Code http://commsalliance.com.au/Documents/all/guidelines/g618
-------------------	---

ANSI/ATIS Committee T1 Publications

ANSI T1.413- 1998	Network and Customer Installation Interfaces - Asymmetric Digital Subscriber Line (ADSL) Metallic Interface
----------------------	---

ATIS- 0600417.2003 (R2007)	Spectrum Management for Loop Transmission Systems. Sept. 2003 http://webstore.ansi.org/RecordDetail.aspx?sku=ATIS-0600417.2003%28R2007%29
----------------------------------	--

ATIS Committee T1 TR 59	Single-Carrier Rate Adaptive Digital Subscriber Line (RADSL) http://webstore.ansi.org/RecordDetail.aspx?sku=T1.TR.59-1999
-------------------------------	---

International Telecommunications Union Recommendations

G.703 (2001/11)	Physical/electrical characteristics of hierarchical digital interfaces http://www.itu.int/itu-t/recommendations/index.aspx?ser=G
--------------------	---

G.961 (1993/03)	Digital transmission system on metallic local lines for ISDN basic rate access http://www.itu.int/itu-t/recommendations/index.aspx?ser=G
--------------------	---

G.991.1 (1998/10)	High bit rate Digital Subscriber Line (HDSL) Transceivers http://www.itu.int/itu-t/recommendations/index.aspx?ser=G
----------------------	--

G.991.2 (2003/12)	Single-Pair High-Speed Digital Subscriber Line (SHDSL) Transceivers http://www.itu.int/itu-t/recommendations/index.aspx?ser=G
----------------------	--

G.992.1 (1999/07)	Asymmetrical Digital Subscriber Line (ADSL) Transceivers http://www.itu.int/itu-t/recommendations/index.aspx?ser=G
----------------------	---

G.992.2 (1999/07)	Splitterless Asymmetric Digital Subscriber Line (ADSL) Transceivers http://www.itu.int/itu-t/recommendations/index.aspx?ser=G
G.992.3 (2009/04)	Asymmetric digital subscriber line transceivers 2 (ADSL2) http://www.itu.int/itu-t/recommendations/index.aspx?ser=G
G.992.4 (2002/07)	Splitterless asymmetric digital subscriber line transceivers 2 (splitterless ADSL2) http://www.itu.int/itu-t/recommendations/index.aspx?ser=G
G.992.5 (2009/01)	Asymmetrical Digital Subscriber Line (ADSL) transceivers - Extended bandwidth ADSL2 (ADSL2+) http://www.itu.int/itu-t/recommendations/index.aspx?ser=G
G.993.1 (2004/06)	Very high speed digital subscriber line transceivers http://www.itu.int/itu-t/recommendations/index.aspx?ser=G
G.996.1 (2001/02)	Test Procedures for Digital Subscriber Line (ADSL) Transceivers http://www.itu.int/itu-t/recommendations/index.aspx?ser=G
K.50 (2000/02)	Safe limits of operating voltages and currents for telecommunication systems powered over the network http://www.itu.int/itu-t/recommendations/index.aspx?ser=K
O.41 (1994/10)	Psophometer for use on telephone-type circuits http://www.itu.int/itu-t/recommendations/index.aspx?ser=O
O.151 (1992/10)	Error performance measuring equipment operating at the primary rate and above http://www.itu.int/itu-t/recommendations/index.aspx?ser=O
O.152 (1992/10)	Error performance measuring equipment for bit rates of 64 kbit/s and N x 64 kbit/s http://www.itu.int/itu-t/recommendations/index.aspx?ser=O
O.153 (1992/10)	Basic parameters for the measurement of error performance at bit rates below the primary rate http://www.itu.int/itu-t/recommendations/index.aspx?ser=O

APPENDIX

A METHOD FOR DETERMINATION OF DEPLOYMENT LIMIT COMPLIANCE.

In order to determine whether a system on a mixed gauge access loop complies with the Deployment Limit for a Deployment Class or meets the equivalent requirement of clause 5.4.4(c), the following calculations shall be performed. The calculation is based on the ULLS Loop Trace. An example of a ULLS Loop Trace is shown in Table A-1.

Table A-1
Example of ULLS Loop Trace Information

Segment Number	Cable Type	Length (m)	Segment Type
1	0.64 PIUT	2100	Inline
2	0.64 PEIUT	500	Inline
3	0.40 CPFUT	250	Inline

From the ULLS Loop Trace, the Calculated Attenuation of the access loop is compared with the Deployment Limit using the following steps.

- (a) The attenuation (in dB at the relevant reference frequency for the Deployment Class - see Table A-1) of each cable segment is determined by calculation from the cable parameters and formulae below;
- (b) The attenuations of all inline segments between the Deployment Reference Point and the ULLS-EURP are summed to give the Calculated Attenuation. The Calculated Attenuation of the access loop of n segments each with length l_i km at frequency f kHz is obtained from the sum of the attenuations of all inline segments in the ULLS Loop Trace:

$$\text{Calculated Attenuation}(f) = \sum_{i=1}^n l_i \times \text{Attenuation}_i(f) \quad (dB)$$

; and

- (c) The Calculated Attenuation is then compared with the specified Deployment Limit for the Deployment Class. The test for compliance with the Deployment Limit is that the Calculated Attenuation does not exceed the Deployment Limit D_k for the relevant Deployment Class k at the specified reference frequency f_{ref} kHz for that class:

$$\text{Compliant if } \text{Calculated Attenuation}(f_{ref}) \leq D_k \quad (dB)$$

For each cable in the access network the attenuation at each of the reference frequencies for the Deployment Classes is given in Table A-2.

Table A-2
Cable loss in dB/km for the different cable types and gauges at the given frequency

Cable Type	Frequency (kHz)																						
	0.82	40	68	96	132	150	196	259	292	300	344	388	439	481	513	545	577	609	649	673	713	1024	3750
.32PIUT	1.90	10.38	12.08	13.03	13.91	14.25	14.95	15.89	16.37	16.49	17.18	17.88	18.68	19.35	19.86	20.39	20.94	21.50	22.20	22.62	23.30	28.24	59.5
.40PIUT	1.50	8.24	9.33	10.01	10.71	11.04	11.89	13.06	13.67	13.81	14.63	15.42	16.33	17.06	17.61	18.15	18.68	19.21	19.85	20.23	20.86	25.40	53.5
.40PEIUT	1.50	7.48	8.32	8.78	9.27	9.50	10.09	10.95	11.41	11.52	12.12	12.72	13.37	13.90	14.31	14.75	15.23	15.71	16.23	16.53	17.00	20.40	38.6
.40CPIUT	1.50	7.90	8.89	9.47	9.99	10.20	10.67	11.94	12.65	12.82	13.56	14.24	15.03	15.69	16.18	16.66	17.14	17.62	18.22	18.57	19.16	23.11	44.7
.40CPFUT	1.50	7.03	7.78	8.23	8.67	8.88	9.48	10.28	10.72	10.79	11.37	11.98	12.65	13.18	13.59	13.99	14.40	14.80	15.28	15.56	16.02	19.28	37.2
.51PIQL	1.17	5.85	6.65	7.45	8.40	8.81	9.75	11.05	11.73	11.90	12.91	13.91	14.87	15.57	16.10	16.67	17.32	17.95	18.60	18.96	19.52	24.53	51.5
.51PEIQL	1.17	5.60	6.15	6.55	7.04	7.29	7.94	8.84	9.31	9.43	10.08	10.71	11.37	11.88	12.25	12.63	13.01	13.39	13.83	14.08	14.48	17.33	33.0
.51PEIUQ	1.17	5.60	6.15	6.55	7.04	7.30	7.94	8.84	9.31	9.43	10.08	10.71	11.37	11.88	12.25	12.63	13.01	13.39	13.83	14.08	14.48	17.33	33.0
.52APIUT	1.50	7.81	8.81	9.38	10.01	10.32	11.08	12.19	12.78	12.92	13.69	14.46	15.34	16.05	16.60	17.14	17.69	18.23	18.88	19.27	19.90	24.55	51.5
.64PIUT	0.94	4.03	4.62	5.14	5.78	6.09	6.88	7.94	8.49	8.62	9.39	10.14	10.89	11.45	11.87	12.29	12.73	13.14	13.43	13.59	13.91	17.95	37.7
.64PIQL	0.94	3.98	4.56	5.26	6.15	6.56	7.53	8.71	9.29	9.43	10.26	11.06	11.78	12.31	12.74	13.24	13.88	14.51	15.11	15.42	15.88	19.70	41.4
.64PEIUT	0.94	3.75	4.06	4.58	5.23	5.49	6.06	6.84	7.24	7.34	7.90	8.45	9.00	9.42	9.73	10.03	10.35	10.65	10.96	11.14	11.43	13.89	26.4
.64CPIUT	0.94	4.59	4.96	5.32	5.85	6.14	6.97	7.94	8.43	8.54	9.15	9.73	10.37	10.86	11.22	11.57	11.90	12.22	12.61	12.83	13.19	15.75	30.5
.64CPFUT	0.94	3.50	4.08	4.54	5.08	5.32	5.88	6.71	7.09	7.19	7.72	8.23	8.76	9.17	9.46	9.75	10.02	10.28	10.59	10.77	11.06	13.12	25.4
.81APIUT	0.94	3.94	4.43	4.89	5.52	5.84	6.65	7.62	8.11	8.23	8.91	9.57	10.25	10.74	11.11	11.47	11.84	12.21	12.64	12.90	13.31	16.36	34.4
.90PIUT	0.65	2.48	2.96	3.47	4.09	4.39	5.09	5.89	6.27	6.36	6.91	7.44	7.99	8.40	8.70	9.01	9.33	9.62	9.84	9.97	10.22	13.29	27.9
.90PIQL	0.65	2.63	3.30	3.98	4.80	5.17	6.03	7.02	7.50	7.61	8.29	8.96	9.64	10.15	10.53	10.91	11.32	11.72	12.18	12.44	12.87	16.13	33.9
.90PIQC	0.65	2.08	2.55	3.04	3.62	3.89	4.51	5.22	5.57	5.65	6.14	6.62	7.12	7.49	7.77	8.06	8.36	8.65	8.98	9.17	9.47	11.79	24.8
.90PEIUT	0.65	2.03	2.35	2.70	3.13	3.34	3.83	4.36	4.61	4.67	5.03	5.38	5.72	5.98	6.16	6.35	6.54	6.73	6.95	7.08	7.29	8.84	16.8
.90CPIUT	0.65	2.32	2.80	3.23	3.75	4.01	4.63	5.32	5.64	5.71	6.13	6.52	6.94	7.27	7.50	7.72	7.93	8.14	8.45	8.65	8.96	10.89	21.1
.90CPFUT	0.65	2.50	3.20	3.46	3.90	4.15	4.84	5.59	5.93	6.01	6.43	6.82	7.22	7.54	7.77	8.01	8.25	8.48	8.75	8.91	9.16	10.89	21.1
.90PIQJ	0.65	2.42	3.04	3.66	4.41	4.76	5.56	6.50	6.95	7.06	7.71	8.34	9.00	9.51	9.89	10.27	10.65	11.03	11.48	11.75	12.18	15.40	32.3
1.15APIUT	0.65	2.57	3.08	3.61	4.25	4.54	5.22	6.01	6.40	6.49	7.04	7.59	8.13	8.54	8.84	9.14	9.46	9.76	10.13	10.35	10.70	13.36	28.1
1.27PIQC	0.45	1.41	1.83	2.25	2.73	2.93	3.37	3.91	4.18	4.24	4.61	4.98	5.37	5.67	5.89	6.11	6.33	6.55	6.82	6.97	7.24	9.23	19.4
1.27PEIQC	0.45	1.45	1.79	2.12	2.49	2.63	2.95	3.34	3.52	3.57	3.84	4.10	4.36	4.56	4.70	4.85	5.00	5.14	5.25	5.30	5.42	6.80	13.2

B MEASUREMENT METHODOLOGY

B1 Introduction

B.1.1 Demonstrating Compliance

Suggested methods for demonstrating compliance of systems with requirements specified in this Code are described in Clauses B.2 to B.4 of Part 1 of this Code.

Other methods may be used if the risk of non-compliance is not increased because of increased measurement uncertainty.

B.1.2 Non-continuous transmission

In order to appropriately represent for interference purposes the impact of short duration high power signals on the ULLS, any signal which is transmitted on the ULLS shall be treated as if it were continuously applied, with no reduction in measured average power or PSD based on the duty cycle. For example a time division duplex system which uses alternate bursts of signal power in each direction of transmission shall be treated as if each direction were operating continuously at the power levels used during the bursts. Also the use of short bursts of tone for any purpose (e.g. training, testing) shall be treated for compliance purposes as if that tone were continuously applied.

B.1.3 Record keeping

The prevailing conditions shall be recorded for each test to measure compliance including measurement uncertainty.

B2 Test configurations for Laboratory Compliance

B.2.1 General

Test configurations used shall be outlined for each individual test. Test circuits other than those indicated in this Code may be used but shall be documented.

B.2.2 Termination impedance

The termination impedance for tests should be as specified for the Deployment Class, or at the relevant impedance for the Non Deployment Class System. The accuracy of the terminating impedance should be taken into account when assessing the measurement uncertainty.

B.2.3 DC line current

Where a device is powered by DC line current, sources DC line current, or sinks or sources DC wetting current, the test conditions should be those which are normally present in use. The test circuits should provide the required current sources and sinks. The AC impedance of the source/sink should be taken into account in the estimation of measurement uncertainty. The balance of the source/sink should also be sufficient to allow the measurement of longitudinal balance.

B.2.4 Equipment state

For many of the tests it is necessary for the system under test to be placed in and maintained in a normal operational state without remote equipment connected. Where this is not possible with the equipment under test, laboratory tests should be

performed with the remote equipment connected through high impedance bridging circuits as described for operational testing in clause B.4 of Part 1 of this Code. Compliance may only be demonstrated within the accuracy of the line termination in such cases.

B3 Laboratory Measurements

B.3.1 Total average power

Total average power is measured using the test circuit in Figure B-1.

For a system which does not supply or sink DC line power, and does not source or sink wetting current, the DC blocking components and DC source/sink are not required.

The total average power should be measured with the system under test terminated in the termination impedance for the Deployment Class, or at the relevant impedance for the Non Deployment Class System

The total average power should be measured over the averaging time for the Deployment Class or at an appropriate averaging time for Non Deployment Class Systems. Note that selection of an appropriate averaging time should be based on the need for adequate settling of instruments to provide an accurate power measurement. The measurement equipment should not be synchronous with the system.

The data input to the system under test should be a pseudo-random sequence, and the system should provide all processes used in normal operation (e.g. scrambling, coding). Pseudo-random sequences should be those specified in O.151, O.152 or O.153 for the appropriate data rate.

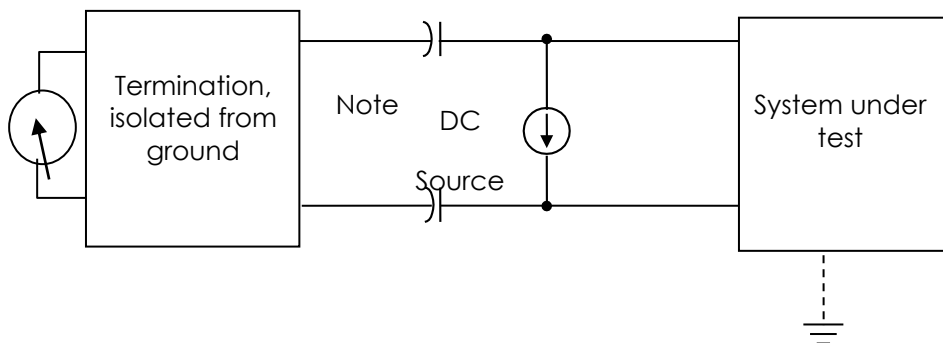

NOTE: The measurement uncertainty needs to take into account the accuracy of the differential termination, including the effect of the blocking capacitors and other equipment.

Figure B-1
Average power and PSD test configuration

B.3.2 Power Spectral Density

The PSD should be measured using the configuration in Figure B-1.

The data input to the system under test should be a pseudo-random sequence, and the system should provide all processes used in normal operation (e.g. scrambling, coding). Pseudo-random sequences should be those specified in the O.151, O.152 or O.153 for the appropriate data rate.

The PSD should be measured using the resolution bandwidths and frequency ranges where specified for the Deployment Class. For Non-Deployment Class Systems the PSD should be measured over a frequency range 0 – 12040 kHz with a resolution bandwidth not greater than 10kHz.

Measurements should be made at discrete frequencies, with a spacing equal to the resolution bandwidth, covering the range specified for the Deployment Class.

The measurement at each frequency should be averaged over a time which takes into account the settling time for the resolution bandwidth. For a measurement bandwidth of 10 kHz at least 2 seconds is required.

To obtain the dynamic range required in the measurement of some Deployment Classes, it may be necessary to use passive filters before the spectrum analyser or selective level meter when measuring the out of band spectrum. If filters are used it is necessary to assure the nominal termination impedance is maintained across the whole signal band.

B.3.3 Longitudinal balance

Longitudinal balance is measured using the test circuit in Figure B-2.

The transmitter of the system under test should be placed in a quiet mode and the termination of the line by the system under test should be maintained.

The DC source/sink and blocking components are not required where the power feed or wetting current is not supported.

The system under test should be earthed as under normal operating conditions.

The residual balance of the test circuit should be at least 20 dB over the limit when a resistor of the termination impedance for the Deployment Class is substituted for the system under test.

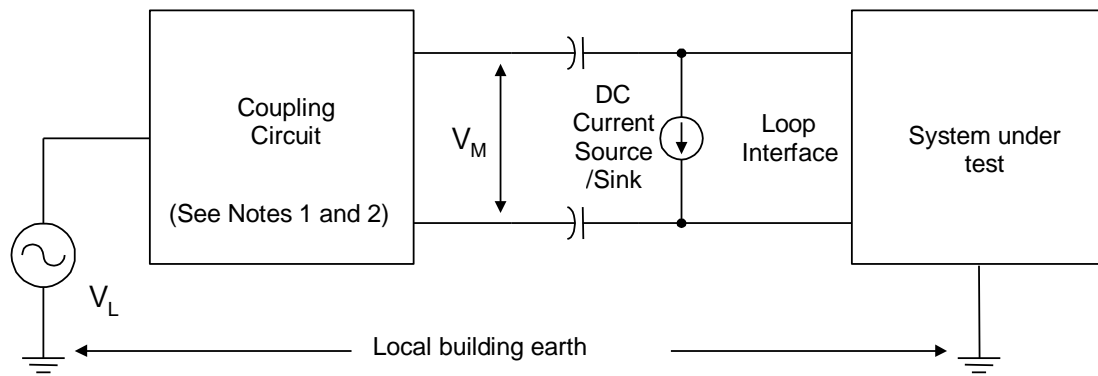

NOTE 1: The impedance of the metallic or differential termination of the coupling circuit is equal to the termination impedance for the Deployment Class, or for Non Deployment Class Systems, a specified value not less than 100 or greater than 150 ohm.

NOTE 2: The longitudinal or common mode termination of the coupling circuit is equal to 1/4 of the differential termination impedance in Note 1.

Figure B-2

Longitudinal balance measurement

B.3.4 Longitudinal output voltage

The longitudinal output voltage should be measured using the circuit in Figure B-3.

The DC source/sink and blocking components are not required where the power feed or wetting current is not supported.

The measurement equipment should not be synchronous with the system.

The data input to the system under test should be a pseudo-random sequence, and the system should provide all processes used in normal operation (e.g. scrambling, coding). Pseudo-random sequences should be those specified in the O.151, O.152 or O.153 for the appropriate data rate.

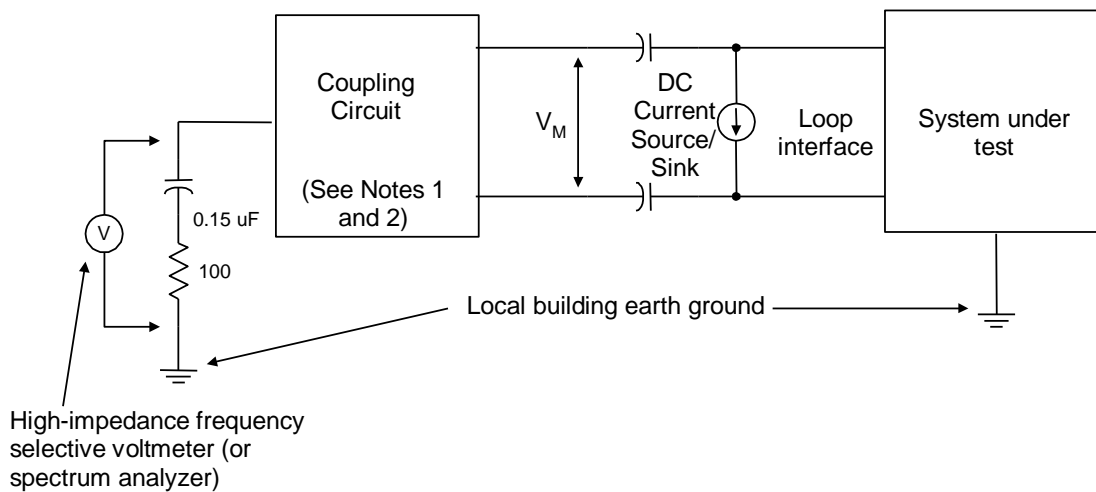

NOTE 1: The impedance of the metallic or differential termination of the coupling circuit is equal to the termination impedance for the Deployment Class, or for Non Deployment Class Systems, a specified value not less than 100 or greater than 150 ohm.

NOTE 2: The longitudinal or common mode impedance of the coupling circuit is equal to 1/4 of the differential termination impedance in Note 1.

Figure B-3
Longitudinal output voltage measurement

B4 Operational Measurements

- B.4.1** Measurements on operational systems need to take into account the measurement uncertainty introduced by the inability to control the termination impedances and measurement environment. On an operational system, measurements of Total Average Power (2.3 of Part 3), Power Spectral Density (2.4 of Part 3) and Longitudinal Output Voltage (2.7 of Part 3) will be possible with reduced accuracy, but measurements of Longitudinal Balance (2.6 of Part 3) will not be possible.
- B.4.2** PSD measurements at the ULLS-NRP, may be adversely affected by "ambient" noise on the tie cable between the MDF and the AS IDF. This "ambient" noise should be taken into account when measurements are made at the ULLS -NRP.
- B.4.3** Longitudinal balance measurements may be adversely affected by the tie cable. By nature of the measurement, it can only be performed by interrupting a service. Measurement may need to be performed at the IDF as well to identify if there is a problem with the AP provided part of the system or the AS part.
- B.4.4** Measurements made at the ULLS-NRP or ULLS-EURP need to take into account the measurement uncertainty at these points. The specifications in this section are for a termination of a resistive load for the class. Measurements made with a distribution network cable connected may result in a measurement uncertainty, due to the termination impedance, of sufficient magnitude for a measurement to be inconclusive in demonstrating compliance or non-compliance. Further measurement uncertainty is a result of the signal from the remote end.
- B.4.5** The transmit power spectral density measurements at the network end of operational systems shall be made at the ULLS-NRP, and at the customer end at the ULLS-EURP or the nearest practicable location.

B.4.6 For operational measurements (or in laboratory measurements where the system under test requires the LT and NT to be connected to enable the system to continuously transmit, then a test set-up similar to Fig. B-4 should be used.

B.4.7 The method of measurement is as follows. With the switches in the calibrate position and using matching transformers with approximately the same impedance as the cable, measure the noise level from the noise source on a spectrum analyser or suitable power meter. Switch Calibrate Probe switch to Differential Probe position, and adjust the differential probe until the power measures the same as in the Calibrate position. The probe should now be calibrated. Switch to Measure and measure the PSD.

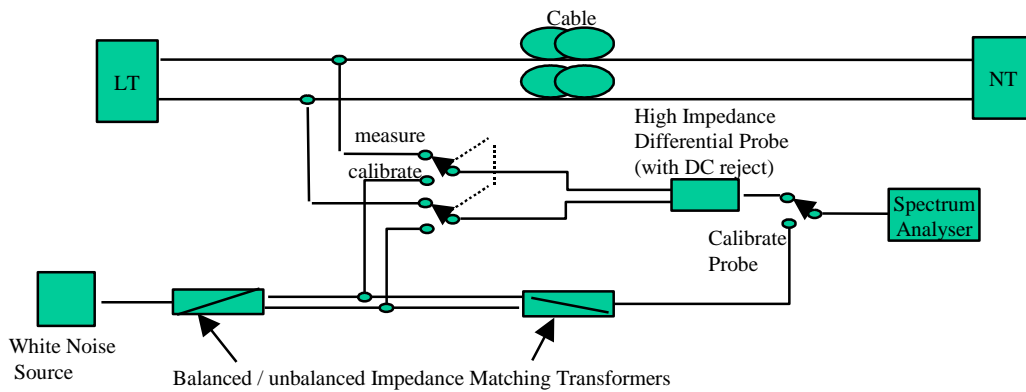

Figure B-4

Test Setup for Measurement of PSD when System transmit cannot be enabled

B.4.8 The minimum impedance to line for the high impedance differential probe shall be 10k Ω . A suitable high impedance bridging circuit is provided in ITU-T Recommendation G.991.2, Figure I-1.

PARTICIPANTS

The Working Committee responsible for the revisions made to this Code consisted of the following organisations and their representatives:

Organisation	Membership	Representative
AAPT	Voting	Nishat Shah
Alcatel-Lucent	Voting	Bruce Orr
Cisco Systems	Voting	Kim Yan
Optus	Voting	Sam Mangar
Primus	Voting	Nigel Lee
Telstra	Voting	Peter Cooke
Telstra	Non-Voting	Phil Potter

This Working Committee was chaired by <insert name>. James Duck of Communications Alliance provided project management support.

Communications Alliance was formed in 2006 to provide a unified voice for the Australian communications industry and to lead it into the next generation of converging networks, technologies and services.

In pursuing its goals, Communications Alliance offers a forum for the industry to make coherent and constructive contributions to policy development and debate.

Communications Alliance seeks to facilitate open, effective and ethical competition between service providers while ensuring efficient, safe operation of networks, the provision of innovative services and the enhancement of consumer outcomes.

It is committed to the achievement of the policy objective of the *Telecommunications Act 1997* - the greatest practicable use of industry self-regulation without imposing undue financial and administrative burdens on industry.



**Published by:
COMMUNICATIONS
ALLIANCE LTD**

**Level 9
32 Walker Street
North Sydney
NSW 2060 Australia**

**Correspondence
PO Box 444
Milsons Point
NSW 1565**

**T 61 2 9959 9111
F 61 2 9954 6136
TTY 61 2 9923 1911
E info@commsalliance.com.au
www.commsalliance.com.au
ABN 56 078 026 507**

Care should be taken to ensure the material used is from the current version of the Standard or Industry Code and that it is updated whenever the Standard or Code is amended or revised. The number and date of the Standard or Code should therefore be clearly identified. If in doubt please contact Communications Alliance