

**COMMUNICATIONS
ALLIANCE LTD**



INDUSTRY GUIDELINE

G642:2010

Installation of Broadcast Cabling and connection
of Digital Broadcast Equipment to a
Telecommunications Network

Industry Guideline – Installation of Broadcast Cabling and connection of Digital Broadcast Equipment to a Telecommunications Network

This Guideline was issued in draft form for public comment as DR G642:2010.

Communications Alliance Ltd (formerly Australian Communications Industry Forum Ltd) was formed in 2006 to provide a unified voice for the Australian communications industry and to lead it into the next generation of converging networks, technologies and services.

Disclaimers

1. Notwithstanding anything contained in this Guideline:
 - (a) Communications Alliance disclaims responsibility (including where Communications Alliance or any of its officers, employees, agents or contractors has been negligent) for any direct or indirect loss, damage, claim, or liability any person may incur as a result of any:
 - (i) reliance on or compliance with this Guideline;
 - (ii) inaccuracy or inappropriateness of this Guideline; or
 - (iii) inconsistency of this Guideline with any law; and
 - (b) Communications Alliance disclaims responsibility (including where Communications Alliance or any of its officers, employees, agents or contractors has been negligent) for ensuring compliance by any person with this Industry.
2. The above disclaimers will not apply to the extent they are inconsistent with any relevant legislation.

Copyright

© Communications Alliance Ltd 2010

This document is copyright and must not be used except as permitted below or under the Copyright Act 1968. You may reproduce and publish this document in whole or in part for your or your organisation's own personal or internal compliance, educational or non-commercial purposes. You must not alter or amend this document in any way. You must not reproduce or publish this document for commercial gain without the prior written consent of Communications Alliance. Organisations wishing to reproduce or publish this document for commercial gain (i.e. for distribution to subscribers to an information service) may apply to subscribe to the Communications Alliance Publications Subscription Service by contacting the Communications Alliance Commercial Manager at info@commsalliance.com.au. If you publish any part of this document for any purpose, you must also publish this copyright notice as part of that publication.

FOREWORD

General

This Guideline was prepared by the Communications Alliance WC18: **Digital Broadcast Interface** Working Committee.

The *Telecommunications Labelling (Customer Equipment and Customer Cabling) Notice 2001* currently identifies applicable standards for Customer Equipment (CE) and Customer Cabling (CC) including analogue Broadcast (video) Equipment designed or intended to connect to Telecommunications Networks operated by Carriers/Carriage Service Providers (C/CSPs).

Under Schedule 1 of the *Telecommunications (Types of Cabling Work) Declaration 1997* ('the Cabling Work Declaration'), Broadcast Cabling Providers performing cabling work are exempt from the requirements of the *Telecommunications Cabling Provider Rules 2000* ('the Cabling Provider Rules') provided they install a Broadcaster Line Isolation Unit (LIU) as the interface to the Telecommunications Network of a C/CSP. The Broadcaster LIU must comply with the applicable technical standards in the *Telecommunications Labelling Notice (ACA TS 024-1997 [8] and AS/NZS 60950.1 [7])*.

With the introduction of digital video and audio broadcasting, the development of new Standards was considered. However, a review carried out by the Communications Alliance CECRP/WG29 Working Group concluded that new Standards were not required and that a Guideline would be a sufficient way to manage the installation of Broadcast Cabling and connection of Digital Broadcast Equipment to a Telecommunications Network.

In coming to this conclusion the Working Group considered the following issues:

- (a) Current industry practices generally take into account digital broadcast interface requirements (such as the necessary minimum mandatory requirements for audio/video interfaces e.g. impedance balance, plugs and sockets) in contracts between the C/CSPs and the Broadcasters/Broadcast Service Providers where network termination equipment is supplied by the C/CSP to suit the particular CE.
- (b) The use of LIUs and the location and access to Broadcast Equipment (for example whether the equipment is in secure locations or in locations with public access).
- (c) The types of Broadcasters and Broadcast Service Providers and the competence of the Broadcast Cabling Providers.
- (d) Safety and integrity of C/CSP Telecommunications Networks.
- (e) The different needs pertaining to permanent services compared to itinerant services.
- (f) Network interface voltage levels for digital broadcast interfaces.
- (g) Arrangements, including service agreements, between a Broadcaster/Broadcast Service Provider and a C/CSP.

It was concluded that the introduction of a new mandatory Standard for Digital Broadcast Equipment would not be appropriate. A Guideline to address all network integrity and safety concerns relating to the connection of Digital Broadcast Equipment and associated cabling was considered sufficient.

This Guideline complements and is based on Free TV Australia Engineering Guideline 08 [9].

This Guideline is the result of a consensus among representatives on the Communications Alliance Working Committee to produce it as an Industry Guideline.

Guideline revision

Industry Guidelines developed by Communications Alliance are updated according to the needs of the industry, by amendments or revision. Users of these Guidelines should make sure that they possess the latest amendments or editions. Representations concerning the need for a change to this Guideline should be addressed to:

The Project Manager
Customer Equipment and Cable Reference Panel
Communications Alliance
PO Box 444
Milsons Point NSW 1565

Regulatory notice

Attention is drawn to the fact that the installation and repair of CC is subject to the Cabling Provider Rules which require CC work to be performed or supervised by a person with the appropriate cabling provider registration and to be installed in accordance with AS/ACIF S009 [7]. This requirement is determined by legislation and subordinate regulatory instruments administered by the ACMA.

Where this Guideline is called up in Schedule 1 of the Cabling Work Declaration, this will have the effect of exempting from the Cabling Provider Rules all Broadcast Cabling work performed in accordance with this Guideline. Where Broadcast Cabling work is not performed in accordance with this Guideline, then all requirements of the Cabling Provider Rules must be met. Inclusion of this Guideline in the Cabling Work Declaration recognises that this Guideline outlines appropriate safety standards and installation practices and provides a sufficient mechanism to ensure that installation is performed in accordance with industry best practice.

The ACMA is a Commonwealth Statutory Authority with powers under the Act to impose requirements on cabling providers concerning customer cabling.

Details on cabling regulations can be obtained from the ACMA website at <http://www.acma.gov.au> or by contacting ACMA below at:

Australian Communications and Media Authority
PO Box 13112
Law Courts
Melbourne VIC 8010
Australia

Telephone: +61 3 9963 6800
Facsimile: +61 3 9963 6899
TTY: +61 3 9963 6948

TABLE OF CONTENTS

1	GENERAL	4
	1.1 Introduction	4
	1.2 Referenced by the ACMA	4
	1.3 Referenced by C/CSPs	4
	1.4 Scope and objectives	4
2	ACRONYMS AND DEFINITIONS	6
	2.1 Acronyms	6
	2.2 Definitions	7
3	REQUIREMENTS	10
	3.1 General	10
	3.2 Health and safety issues associated with Digital Broadcast Equipment	10
	3.3 Health and safety issues associated with CC/Broadcast Cabling	11
	3.4 Digital Broadcast Interfaces on Digital Broadcast Equipment	11
3	REFERENCES	13
	PARTICIPANTS	15

1 GENERAL

1.1 Introduction

- 1.1.1 This Guideline provides guidance for installation of Broadcast Cabling and digital broadcast interfaces used with Digital Broadcast Equipment intended for connection to a C/CSP's Telecommunications Network.
- 1.1.2 The requirements in this Guideline seek to provide recommendations which are consistent with the aims of the *Telecommunications Act 1997*. Specifically these aims are to:
 - (a) protect the integrity of a Telecommunications Network; and
 - (b) protect the health and safety of persons.
- 1.1.3 This Guideline is not device specific.

1.2 Referenced by the ACMA

- 1.2.1 Where this Guideline is referenced by the ACMA in the Cabling Work Declaration, this will have the effect of exempting from the Cabling Provider Rules all Broadcast Cabling work performed in accordance with this Guideline. The Cabling Provider Rules reference the Cabling Work Declaration to determine whether any cabling work which is not of a kind mentioned in Schedule 1 of the Declaration is a type of cabling for the purposes of Division 9 of Part 21 of the *Telecommunications Act 1997*.

1.3 Referenced by C/CSPs

- 1.3.1 Any service agreement for digital broadcast carriage services between a C/CSP and a Broadcaster/Broadcast Service Provider should reference this Guideline.

1.4 Scope and objectives

- 1.4.1 This Guideline describes the requirements in relation to the connection between:
 - (a) a C/CSP's Telecommunications Network at the Network Boundary; and
 - (b) Digital Broadcast Equipment or Broadcast Cabling.
- 1.4.2 In respect of Digital Broadcast Equipment, a requirement for connection to a C/CSP's Telecommunications Network is that either the Digital Broadcast Equipment:
 - (a) complies with this Guideline under Section 3; or
 - (b) it has digital broadcast interfaces other than those listed in this Guideline under Section 3 for which the C/CSP has provided written consent to the concerned

Broadcaster/Broadcast Service Provider to connect to its Telecommunications Network.

- 1.4.3 In respect of Broadcast Cabling, a requirement for connection to a C/CSP's Telecommunications Network is that the Broadcast Cabling is connected via the input or output digital broadcast interfaces of the Digital Broadcast Equipment and that either the Digital Broadcast Equipment:
- (a) complies with this Guideline under Section 3; or
 - (b) it has digital broadcast interfaces other than those listed in this Guideline under Section 3 for which the C/CSP has provided written consent to the concerned Broadcaster/Broadcast Service Provider to connect to its Telecommunications Network.

2 ACRONYMS AND DEFINITIONS

2.1 Acronyms

For the purposes of this Guideline:

ACA

means Australian Communications Authority

ACMA

means Australian Communications and Media Authority

AES

means Audio Engineering Society

CE

means Customer Equipment

CC

means Customer Cabling

C/CSP

means Carrier/Carriage Service Provider

ETSI

means European Telecommunications Standards Institute

IEC

means International Electrotechnical Commission

IRE

means Institute of Radio Engineers

ITU-R

means International Telecommunications Union – Radiocommunications

ITU-T

means International Telecommunications Union – Telecommunications

LIU

means Line Isolation Unit

SMPTE

means Society of Motion Picture and Television Engineers

SI

means International System

XLR

means the 'Canon X' series, subsequent versions added a Latch ('Canon XL') and then a Rubber compound surrounding the contacts, which led to the abbreviation XLR

2.2 Definitions

For the purposes of this Guideline:

Broadcast Cabling

means CC used in producing or supplying a broadcast service, including data and video cabling for carriage of digital audio/visual bitstreams.

Broadcast Cabling Provider

means a person who performs Broadcast Cabling work.

Broadcast Equipment

means CE used principally as specialist facilities by a Broadcaster/Broadcast Service Provider, but does not include general purpose CE, e.g. telephones, facsimile machines, modems.

Broadcaster

means:

- (a) the Australian Broadcasting Corporation; or
- (b) the Special Broadcasting Service Corporation; or
- (c) a person holding a licence under Parts 4, 6, 7 or 8 of the *Broadcasting Services Act 1992*.

Broadcast Service Provider

means a person who provides a third party service for the carriage of digital audio/visual bitstreams to the broadcast and other audio visual industry sectors and in the course of providing this service, provides Broadcast Cabling to connect Digital Broadcast Equipment to a C/CSP's Telecommunications Network.

Cabling work

has the meaning given by s418 of the *Telecommunications Act 1997* as a reference to:

- (a) the installation of CC for connection to a Telecommunications Network;
- (b) the connection of CC to a Telecommunications Network; or

- (c) the maintenance of CC connected to a Telecommunications Network or to a facility.

[*Telecommunications Act 1997*]

Carrier

means the holder of a Carrier licence.

[*Telecommunications Act 1997*]

Carriage Service Provider

means a person who supplies, or proposes to supply, a listed carriage service to the public using:

- (a) a network unit owned by one or more Carriers; or
- (b) a network unit in relation to which a nominated Carrier declaration is in force.

[*Telecommunications Act 1997*]

Customer Cabling

means a line that is used, installed ready for use or intended for use on the customer side of the boundary of a Telecommunications Network.

[*Telecommunications Act 1997*]

Customer Equipment

means:

- (a) any equipment, apparatus, tower, mast, antenna or other structure or thing that is used, installed ready for use or intended for use on the customer side of the boundary of a Telecommunications Network; or
- (b) any system (whether software-based or otherwise) that is used, installed ready for use or intended for use on the customer side of the boundary of a Telecommunications Network;

but not including a line.

[*Telecommunications Act 1997*]

Digital Broadcast Equipment

means Broadcast Equipment with one or more digital broadcast interfaces.

Network Boundary

means a point which is the boundary of a C/CSP's Telecommunications Network for determining whether cabling or equipment is 'CC' or 'CE' for the purpose of technical regulation under Part 21 of the *Telecommunications Act 1997*.

Note: In the context of this Guideline, the Network Boundary will usually be an agreed point between the C/CSP and the Broadcaster/Broadcast Service Provider.

Telecommunications Network

a system, or series of systems that is operated by a C/CSP and which carries, or is capable of carrying, communications by means of guided and/or unguided electromagnetic energy.

[*Telecommunications Act 1997*]

Types of Cabling Work

has the meaning given by s419 (1) of the *Telecommunications Act 1997* and the Cabling Work Declaration made pursuant to that subsection.

3 REQUIREMENTS

3.1 General

- 3.1.1 The requirements of this Section apply to digital broadcast interfaces used with Digital Broadcast Equipment to connect to a C/CSP's Telecommunications Network unless the C/CSP has provided written consent to the concerned Broadcaster/Broadcast Service Provider to connect digital broadcast interfaces other than those listed in this Section to its Telecommunications Network.
- 3.1.2 Figure 1 shows the connection of Digital Broadcast Equipment, scoped by this Guideline, to a C/CSP's Telecommunications Network.

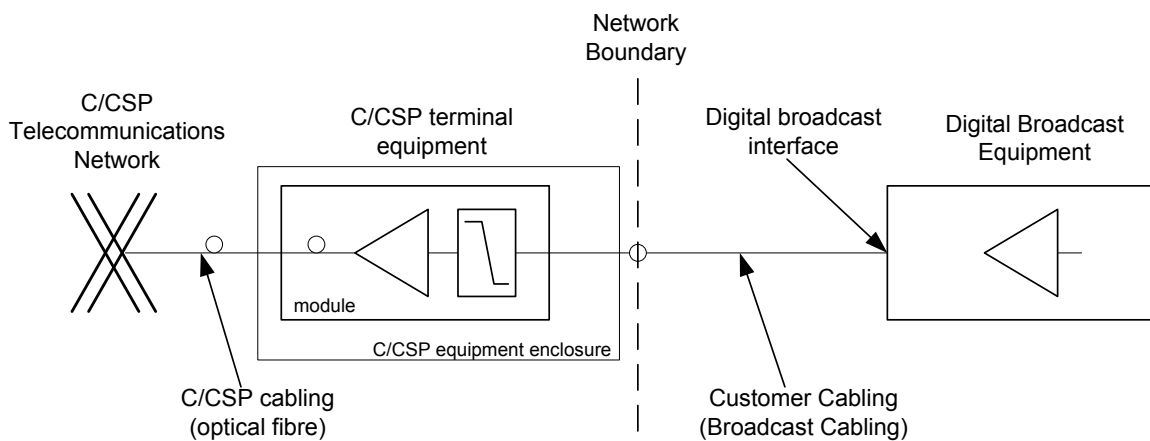

Figure 1

Connection of Digital Broadcast Equipment to a C/CSP's Telecommunications Network

3.2 Health and safety issues associated with Digital Broadcast Equipment

- 3.2.1 The ACMA adopts AS/NZS 60950.1 [6] as amended from time to time as an appropriate safety Standard for CE and CC. This ensures that requirements under s376 of the *Telecommunications Act 1997* are met, especially with regard to the health and safety of persons who operate, work on, use services supplied by means of, or are otherwise reasonably likely to be affected by the operation of the Telecommunications Network.
- 3.2.2 Digital Broadcast Equipment must comply with an applicable safety standard for its particular design and application. If there is

any doubt then AS/NZS 60950.1 [6] (as amended from time to time) should be used as the applicable safety Standard.

3.3 Health and safety issues associated with CC/Broadcast Cabling

- 3.3.1 Installation and connection of all CC/Broadcast Cabling, including optical fibre and coaxial systems, must comply with appropriate safety Standards and installation practices. The applicable Standards/practices for CC/Broadcast Cabling installations are:
- (a) AS/ACIF S009 [7], equivalent Industry installation practices, or in accordance with industry Occupational Health and Safety policy;
 - (b) AS/NZS 2211 [1] to [5]; and
 - (c) Specific broadcast industry connector standards and cabling specifications and standards applicable to each broadcast interface as listed under Clause 3.4.5.

3.4 Digital Broadcast Interfaces on Digital Broadcast Equipment

- 3.4.1 Several digital broadcast formats, including MPEG2 and MPEG4, are currently used by Broadcasters/Broadcast Service Providers.
- 3.4.2 As Standards and new technologies can evolve rapidly in the broadcasting environment, the set of video and audio formats expected to be delivered via the C/CSP's Telecommunication Networks into the Broadcaster/Broadcast Service Provider's network environment is also rapidly evolving.
- 3.4.3 Digital broadcast interfaces on Digital Broadcast Equipment, as operated by the Broadcasters/Broadcast Service Providers, must comply with these Standards as listed in Clause 3.4.5 which define the video resolution for MPEG-2 and MPEG-4, coding characteristics, data formats, electrical and mechanical characteristics of the interface, error rate and characteristics of the optical fibre interfaces.
- 3.4.4 Service agreements for digital broadcast carriage services between the C/CSP and the Broadcaster/Broadcast Service Provider must identify the types of digital broadcast interfaces required at the Network Boundary of the C/CSP's Telecommunications Network. This may extend to the connection point as specified by the C/CSP.
- 3.4.5 The Standards for digital broadcast interfaces on Digital Broadcast Equipment are one or more of the following:
- (a) ITU-R BT.656 *Interface for digital component video signals in 525-line and 625-line television systems operating at the 4:2:2 level of Recommendation ITU-R BT.601* [10]
 - (b) ITU-R BT.1120 *Digital interfaces for HDTV studio signals* [11]

- (c) AES-3id-2001 (r2006) *AES information document for Digital audio engineering – Transmission of AES3 formatted data by unbalanced coaxial cable* (Revision of AES-3id-1995) [12]
- (d) SMPTE 276M–1995 *Transmission of AES-EBU Digital Audio Signals Over Coaxial Cable* [13]
- (e) SMPTE 259M–2008 *SDTV Digital Signal/Data – Serial Digital Interface*[14]
- (f) SMPTE 292M–2008 *1.5 Gb/s Signal / Data Serial Interface* [15]
- (g) SMPTE 297M–2006 *Serial Digital Fibre Transmission System for SMPTE 259M, SMPTE 344M, SMPTE 292 and SMPTE 424M Signals* [16]
- (h) SMPTE 372M–2009 *Dual Link 1.5 Gb/s Digital Interface for 1920 x 1080 and 2048 x 1080 Picture Formats* [17]
- (i) SMPTE 424M–2006 *3 Gb/s Signal/Data Serial Interface* [18]
- (j) SMPTE 435-1-2009 *10 Gb/s Serial Signal/Data Interface – Part 1: Basic Stream Distribution* [19]
- (k) SMPTE 435-2–2009 *10 Gb/s Serial Signal/Data Interface – Part 2: 10.692 Gb/s Stream – Basic Stream Data Mapping* [20]
- (l) SMPTE 435-3–2009 *10 Gb/s Serial Signal/Data Interface – Part 3: 10.692 Gb/s Optical Fiber Interface* [21]

3 REFERENCES

	Publication	Title
Australian Standards		
	AS/NZS 2211	Safety of laser products
[1]	AS/NZS 2211.1: 2006	Part 1: Equipment classification, requirements and user's guide
[2]	AS/NZS 2211.2: 2006	Part 2: Safety of optical fibre communication systems
[3]	AS/NZS 2211.9: 2006	Part 9: Compilation of maximum permissible exposure to incoherent optical radiation
[4]	AS/NZS 2211.10: 2006	Part 10: Application guidelines and explanatory notes to AS/NZS 2211.1
[5]	AS/NZS 2211.12: 2006	Part 12: Safety of free space optical communication systems used for transmission of information
[6]	AS/NZS 60950.1:2003	Safety of information technology equipment (as reviewed or amended from time to time)
AS/ACIF Standards		
[7]	AS/ACIF S009:2006	Installation requirements for Customer Cabling (Wiring Rules)
ACA Standards		
[8]	TS 024-1997	Telecommunications Technical Standard (Broadcast Interface Standard – ACA TS024 – 1997)
Industry Guidelines		
[9]	Free TV Australia Engineering Guideline 08	Broadcaster Network Digital Boundary Interface
ITU-T Recommendations		
[10]	ITU-R BT.656	Interface for digital component video signals in 525-line and 625-line television systems operating at the 4:2:2 level of Recommendation ITU-R BT.601
[11]	ITU-R BT.1120	Digital interfaces for HDTV studio signals

	Publication	Title
	Other international Standards	
[12]	AES-3id-2001 (r2006)	AES information document for Digital audio engineering - Transmission of AES3 formatted data by unbalanced coaxial cable (Revision of AES-3id-1995)
[13]	SMPTE 276M-1995	Transmission of AES-EBU Digital Audio Signals Over Coaxial Cable
[14]	SMPTE 259M-2008	SDTV Digital Signal/Data – Serial Digital Interface
[15]	SMPTE 292M-2008	1.5 Gb/s Signal / Data Serial Interface
[16]	SMPTE 297M - 2006	Serial Digital Fiber Transmission System for SMPTE 259M, SMPTE 344M, SMPTE 292 and SMPTE 424M Signals
[17]	SMPTE 372M-2009	Dual Link 1.5 Gb/s Digital Interface for 1920 x 1080 and 2048 x 1080 Picture Formats
[18]	SMPTE 424M-2006	3 Gb/s Signal/Data Serial Interface
[19]	SMPTE 435-1-2009	10 Gb/s Serial Signal/Data Interface – Part 1: Basic Stream Distribution
[20]	SMPTE 435-2-2009	10 Gb/s Serial Signal/Data Interface – Part 2: 10.692 Gb/s Stream – Basic Stream Data Mapping
[21]	SMPTE 435-3-2009	10 Gb/s Serial Signal/Data Interface – Part 3: 10.692 Gb/s Optical Fibre Interface

PARTICIPANTS

The Working Committee that developed this Guideline consisted of the following organisations:

Organisation	Membership	Representative
Australian Broadcasting Corporation	Voting	Benny Xiang
Australian Communications and Media Authority (ACMA)	Non-voting	Nick McKillop
Commercial Radio Australia	Voting	Robert Greeney
Community Broadcasting Association of Australia	Voting	David Sice
Free TV Australia	Non-voting	Roger Bunch
Global Television	Voting	Terry Manley
Jands Pty Ltd	Voting	Jeff MacKenzie
Network TEN Australia	Voting	Glenn Carrick
Nine Network Australia	Voting	Tony Anthony
Seven Network Australia	Voting	David Watts
SingTel Optus	Voting	Sanjeev Mangar
Special Broadcasting Service	Voting	Colin Elston
Syntec	Voting	Robert Sloss
Telstra	Voting	Peter Jones

This Working Committee was chaired by Roger Bunch, Free TV Australia. Mike Johns of Communications Alliance provided project management support.

Communications Alliance was formed in 2006 to provide a unified voice for the Australian communications industry and to lead it into the next generation of converging networks, technologies and services.

In pursuing its goals, Communications Alliance offers a forum for the industry to make coherent and constructive contributions to policy development and debate.

Communications Alliance seeks to facilitate open, effective and ethical competition between service providers while ensuring efficient, safe operation of networks, the provision of innovative services and the enhancement of consumer outcomes.

It is committed to the achievement of the policy objective of the *Telecommunications Act 1997* - the greatest practicable use of industry self-regulation without imposing undue financial and administrative burdens on industry.



**Published by:
COMMUNICATIONS
ALLIANCE LTD**

**Level 9
32 Walker Street
North Sydney
NSW 2060 Australia**

**Correspondance
PO Box 444
Milsons Point
NSW 1565**

**T 61 2 9959 9111
F 61 2 9954 6136
TTY 61 2 9923 1911
E info@commsalliance.com.au
www.commsalliance.com.au
ABN 56 078 026 507**

Care should be taken to ensure the material used is from the current version of the Standard or Industry Code and that it is updated whenever the Standard or Code is amended or revised. The number and date of the Standard or Code should therefore be clearly identified. If in doubt please contact Communications Alliance