

**COMMUNICATIONS
ALLIANCE LTD**



AUSTRALIAN STANDARD

AS/ACIF S041.3:2009

Requirements for DSL Customer Equipment for
connection to the Public Switched Telephone
Network – Part 3: Filters for use in connection with
all ADSL services

**Adopted for
regulatory purposes**

Australian Standard – Requirements for DSL Customer Equipment for connection to the Public Switched Telephone Network – Part 3: Filters for use in connection with all DSL services

This Standard was issued in draft form for public comment as DR AS/ACIF S041.3:2008.

First published as AS/ACIF S041:2005

Second edition as AS/ACIF S041.3:2009

ISBN: 1 74000 391 8

Communications Alliance Ltd was formed in 2006 to provide a unified voice for the Australian communications industry and to lead it into the next generation of converging networks, technologies and services. ACIF is a division of Communications Alliance.

Disclaimers

1. Notwithstanding anything contained in this Standard:
 - (a) Communications Alliance disclaims responsibility (including where Communications Alliance or any of its officers, employees, agents or contractors has been negligent) for any direct or indirect loss, damage, claim, or liability any person may incur as a result of any:
 - (i) reliance on or compliance with this Standard;
 - (ii) inaccuracy or inappropriateness of this Standard; or
 - (iii) inconsistency of this Standard with any law; and
 - (b) Communications Alliance disclaims responsibility (including where Communications Alliance or any of its officers, employees, agents or contractors has been negligent) for ensuring compliance by any person with this Standard.
2. The above disclaimers will not apply to the extent they are inconsistent with any relevant legislation.

Copyright

© Commonwealth of Australia 2009

This work is copyright. Apart from any use as permitted under the Copyright Act 1968, no part may be reproduced by any process without prior written permission from the Commonwealth available from AusInfo. Requests and inquiries concerning reproduction and rights should be addressed to the Manager, Legislative Services, AusInfo, GPO Box 1920, Canberra ACT 2601 or by email to cwealthcopyright@dofa.gov.au.

FOREWORD

General

This Standard was prepared by Communications Alliance and most recently revised by the WC12 : *ADSL Filter/Splitter Revision* Working Committee. It is one of a series of Telecommunication Standards developed under the Memorandum of Understanding between the Australian Communications Authority (ACA) and the Australian Communications Industry Forum.

Note: On 1 July 2005 the ACA became the Australian Communications and Media Authority (ACMA) and the Memorandum of Understanding continues in effect as if the reference to the ACA were a reference to ACMA.

This Standard is a revision of AS/ACIF S041:2005 *Requirements for DSL Customer Equipment for connection to the Public Switched Telephone Network*. It is the result of a consensus among representatives on the Communications Alliance Working Committee to produce it as an Australian Standard.

The requirements in this Standard are consistent with the aims of s376 of the *Telecommunications Act 1997*. Specifically these aims are—

- (a) protecting the integrity of a telecommunications network or facility;
- (b) protecting the health and safety of persons;
- (c) ensuring access to emergency services; and
- (d) ensuring interoperability with a standard telephone service.

It should be noted that some Customer Equipment (CE) may also need to comply with requirements in other Standards or other Parts of this Standard.

Part 3 of this Standard should be read in conjunction with AS/ACIF S041.1 [3]

Applicable electrical safety Standards and EMC Standards may apply under Commonwealth or State laws, or both.

Intellectual property rights

Equipment which is manufactured to comply with this Standard may require the use of technology which is protected by patent rights in Australia. Questions about the availability of such technology, under licence or otherwise, should be directed to the patent holder or Australian licensee (if known) or through enquiry at IP Australia which incorporates the Patent, Designs and Trade Marks and Offices. Further information can be found at www.ipaustralia.gov.au.

Standards revision

Australian Standards (AS/ACIF Standards) developed by the Australian Communications Industry Forum, a division of Communications Alliance, are updated according to the needs of the industry, by amendments or revision. Users of AS/ACIF Standards should make sure that they possess the latest amendments or editions. Representations concerning the need for a change to this AS/ACIF Standard should be addressed to:

The Project Manager
Customer Equipment and Cable Reference Panel
Communications Alliance
PO Box 444
Milsons Point NSW 1565

Regulatory notice

This document has been made by ACMA as Telecommunications Technical Standard AS/ACIF S041.3–2009 under s376 of the *Telecommunications Act 1997*.

ACMA is a Commonwealth authority with statutory powers to impose requirements concerning telecommunications Customer Equipment and Customer Cabling.

ACMA requires Australian manufacturers and importers, or their Australian agents, of specified items of Customer Equipment and Customer Cabling to establish compliance with Standards such as this. Items are required to be labelled in accordance with the applicable labelling notices.

Details on current compliance arrangements can be obtained from the ACMA website at <http://www.acma.gov.au> or by contacting ACMA below at:

Australian Communications and Media Authority
PO Box 13112
Law Courts PO
Melbourne VIC 8010
Australia

Telephone: +61 3 9963 6800
Facsimile: +61 3 9963 6899
TTY: +61 3 9963 6948

Introduction

This introduction for the AS/ACIF S041.3 **Requirements for DSL Customer Equipment for connection to the Public Switched Telephone Network – Part 3: Filters for use in connection with all ADSL services** Standard is not an authoritative section of this Standard and is only provided as guidance for the user of the Standard to outline its objectives, the factors that have been taken into account in its development and to list the principle differences between the new and the previous edition.

The reader is directed to the clauses of this Standard for the specific requirements and to the Australian Communications and Media Authority (ACMA) for the applicable telecommunications labelling and compliance arrangements.

Note: Further information on the telecommunications labelling and compliance arrangements can be found in *The Telecommunications Labelling (Customer Equipment and Customer Cabling) Notice* (the TLN). The TLN can be obtained from the Australian Communications and Media Authority (ACMA) website at www.acma.gov.au.

The objective of this Standard is to provide the technical requirements and test methods for Customer Equipment (CE), or the parts of CE that are designed or intended for connection to a DSL service that shares the metallic local loop with an analogue PSTN two-wire service in order to meet the regulatory arrangements for such equipment in Australia.

The objective of this revision is to include requirements currently specified in the Telstra RCIT.0004 ADSL Splitter Specification to bring the Standard in line with the ADSL services being offered by Australian broadband service providers and to restructure the Standard as a multi-part Standard to streamline the compliance testing separately of DSL modems and ADSL splitters/filters.

The principal differences between this edition of AS/ACIF S041.3 and the previous edition of AS/ACIF S041 are that—

- (i) only requirements specifically related to DSL filters are included.
- (ii) ADSL filters are to be identified to avoid Centralised and Distributed filters being incorrectly used.
- (iii) ADSL filters are to be labelled to identify compliance with the latest standard and suitability for installation.
- (iv) DC series resistance requirements now specified out to 80 mA.
- (v) Table 1 re-drawn to ensure return loss measurements are done in each direction and with the correct impedances.
- (vi) LCTL limits of Table 2 deleted with the LCL limits now to be met for all unbalance measurements.
- (vii) Alternate test procedures added for filter loss measurements.
- (viii) Noise measurements will now be done with two un-terminated filters in parallel.
- (ix) Filter loss measurements are now done with a representation of the modem impedance present as well as not present.

Informative Statement on the POTS impact on ADSL2+/ADSL2/ADSL services

Because of difficulties in specification, tests relating to the impact of POTS signalling events through the filter onto the ADSL2+/ADSL2/ADSL service have not been included in this Standard. Designers of filters are advised to take into account the POTS interference mechanisms known to cause degradation of ADSL2+/ADSL2/ADSL services, as described in Clause 5.3.19.

Therefore it must be recognised that Carriers and Carriage Service Providers may need to protect their ADSL2+/ADSL2/ADSL services by not listing as approved, and actively removing from service any filter type (that may have been tested and labelled as complying to this Standard) that causes degradation due to mechanisms like those above that have not been included in this Standard.

TABLE OF CONTENTS

1	INTERPRETATIVE GUIDELINES	1
	1.1 Categories of requirements	1
	1.2 Compliance statements	1
	1.3 Definitions, expressions and terms	1
	1.4 Notes	1
	1.5 References	1
	1.6 Units and symbols	1
2	SCOPE	2
3	REFERENCES	3
4	ABBREVIATIONS AND DEFINITIONS	5
	4.1 Abbreviations	5
	4.2 Definitions	5
	4.2.1 Carrier	5
	4.2.2 Carriage Service Provider	5
	4.2.3 Centralised Filter (Master Splitters)	5
	4.2.4 Customer Equipment	6
	4.2.5 Distributed Filters ('in-line' filters or 'micro-filters')	6
	4.2.6 Facility	6
	4.2.7 Line Port	6
	4.2.8 Line Terminating Equipment	6
	4.2.9 Local Port	6
	4.2.10 Metallic local loop	7
	4.2.11 Off-line	7
	4.2.12 Off-hook	7
	4.2.13 On-line	7
	4.2.14 On-hook	7
	4.2.15 Public Switched Telephone Network (PSTN)	7
	4.2.16 Standard Telephone Service	7
	4.2.17 Telecommunications Network	7
	4.2.18 Telecommunications Reference Conductor (TRC)	7
	4.2.19 Voice Frequency (VF)	7
	4.2.20 Voiceband	8
5	REQUIREMENTS	9
	5.1 General	9
	5.1.1 Filters used in conjunction with all ADSL services	9
	5.1.2 Provision of advice on the suitability of the device	9
	5.2 Filter types	9
	5.2.1 General	9

5.2.2	<i>Distributed Filters ('in-line' filters or 'micro-filters')</i>	10
5.2.3	<i>Centralised Filter (Master Splitters)</i>	10
5.2.4	<i>Distributed and centralised filter labelling</i>	10
5.3	Technical Requirements	10
5.3.1	<i>Home networking</i>	10
5.3.2	<i>DC current range</i>	11
5.3.3	<i>Reference Impedance</i>	11
5.3.4	<i>Test Impedances</i>	11
5.3.5	<i>DC series resistance</i>	11
5.3.6	<i>Ringling voltage drop</i>	12
5.3.7	<i>Return loss</i>	12
5.3.8	<i>Unbalance about Earth</i>	12
5.3.9	<i>Group Delay Distortion</i>	13
5.3.10	<i>Voiceband Filter Loss 'On-Line'</i>	14
5.3.11	<i>Voice Band Filter Loss distortion 'On-Line'</i>	14
5.3.12	<i>Voiceband Filter Loss 'Off-line'</i>	15
5.3.13	<i>Intermodulation distortion</i>	15
5.3.14	<i>ADSL band filter loss On-line state</i>	15
5.3.15	<i>ADSL band filter loss Off-line state</i>	16
5.3.16	<i>LINE Port impedance Offline state</i>	17
5.3.17	<i>Noise in Voiceband</i>	17
5.3.18	<i>Noise in ADSL band</i>	18
5.3.19	<i>PSTN transient effects</i>	18
5.3.20	<i>Parallel operation</i>	19
6	TESTING	20
6.1	Verification of compliance with requirements	20
6.2	Standard test conditions	20
6.3	Levels	21
6.4	Test frequencies	21
6.5	Parameters to be tested	21
6.5.1	<i>Ringling characteristics</i>	21
6.5.2	<i>Return loss</i>	21
6.5.3	<i>Impedance balance</i>	21
6.5.4	<i>Filter loss</i>	22
6.5.5	<i>Noise performance</i>	22
6.5.6	<i>Signal levels and frequencies</i>	22
6.5.7	<i>Test for POTS Transient effects</i>	22
6.5.8	<i>Parallel Handover</i>	22
PARTICIPANTS		36

FIGURES

1	Reference impedances	23
2	Test circuit for ring characteristics of xDSL filters	24
3	Test for xDSL filter balance about earth	25
4	Noise measurements psophometric, single frequency and unweighted	26
5	Psophometric noise measurements	26
6	Test for PSTN transient effects	27
7	Return loss measurements	28
8	Group delay measurements	29
9	Voiceband filter loss (on-line) / distortion measurements	30
10	Voiceband filter loss (off-line) measurements	31
11	Intermodulation measurements	32
12	DSL band loss measurements	33
13	ADSL band noise measurements	34
14	Test circuit for parallel handover	34
15	Filter use for isolation of DSL functions from PSTN CE	35

TABLES

1	ADSL filter return loss	13
2	DSL filter balance	13
3	Group delay distortion	14
4	Loss requirements in the On-line state	15
5	Recommended loss in the On-line state	16
6	Loss in the Off-line state with a 120 Ω Source	16
7	Loss in the Off-line state with a Z_{RHF} Source	17
8	Line Port Impedance in the Off Line State	17

1 INTERPRETATIVE GUIDELINES

1.1 Categories of requirements

This Standard contains mandatory requirements as well as provisions that are recommendatory only. Mandatory requirements are designated by the words '**shall**' or '**shall not**'. All other provisions are voluntary.

1.2 Compliance statements

Compliance statements, in italics, suggest methodologies for demonstrating CE's compliance with the requirements.

1.3 Definitions, expressions and terms

If there is any conflict between the definitions used in this Standard and the definitions used in the *Telecommunications Act 1997*, the definitions in the Act take precedence.

1.4 Notes

Text denoted as 'Note' is for guidance in interpretation and is shown in smaller size type.

1.5 References

- (a) Applicable editions (or versions) of other documents referred to in this Standard are specified in Section 3: REFERENCES.
- (b) If a document refers to another document, the other document is a sub-referenced document.
- (c) Where the edition (or version) of the sub-referenced document is uniquely identified in the reference document, then that edition (or version) applies.
- (d) Where the edition (or version) of the sub-referenced document is not uniquely identified in the reference document, then the applicable edition (or version) is that which is current at the date the reference document is legislated under the applicable regulatory framework, or for a non-legislated document, the date upon which the document is published by the relevant standards organisation.
- (e) A number in square brackets '[]' refers to a document listed in Section 3: REFERENCES.

1.6 Units and symbols

In this Standard the International System (SI) of units and symbols is used in accordance with Australian Standard AS ISO 1000 [1].

2 SCOPE

- 2.1 This Standard specifies the technical requirements for ADSL Filter Customer Equipment (CE), or the ADSL Filter parts of the CE that are designed or intended for connection to an ADSL service that shares the metallic local loop with an analogue PSTN two-wire service.
- 2.2 This Standard does not apply to CE or the parts of CE designed or intended only for connection to an analogue PSTN two-wire service.
- 2.3 CE is not excluded from the scope of this Standard by reason only that it is capable of performing functions additional to those listed in this Standard.

Note 1: For the purposes of this scope ADSL filters are examples of CE designed for connection to a DSL service operating over a shared metallic local loop with an analogue PSTN two-wire service.

Note 2: AS/ACIF S002 [2] specifies the technical requirements for connection to an analogue PSTN two-wire service.

3 REFERENCES

	Publication	Title
	Australian Standards	
[1]	AS ISO 1000-1998	The international System of Unit (SI) and its application.
	AS/ACIF Standards	
[2]	AS/ACIF S002:2005	Analogue interworking and non-interference requirements for Customer Equipment for connection to the Public Switched Telephone Network
	AS/ACIF S041	Requirements for DSL Customer Equipment for connection to the Public Switched Telephone Network
[3]	AS/ACIF S041.1:2009	Part 1: General
	AS/ACIF S043	Requirements for Customer Equipment for connection to a metallic local loop interface of a Telecommunications Network
[4]	AS/ACIF S043.2:2005	Part 2: Broadband
	ACIF Guidelines	
[5]	ACIF G534:2003	Assessment of Emergency Service Access and Network
	ETSI Standards and Reports	
[6]	ETSI TS 101 952-1-1 V1.2.1 (2004-12)	Access Network xDSL Transmission Filters; Part 1; ADSL Splitters for European Deployment; Sub Part 1:Generic Specification of the Low Pass Part of DSL over POTS Splitters including Dedicated Annexes for Specific xDSL Variants
[7]	ETSI TS 101 952-1-5 V1.2.1 (2006-10)	Access Network xDSL Transmission Filters; Part 1; ADSL Splitters for European Deployment; Sub Part 5: Specification for ADSL over POTS Distributed Filters
[8]	TR 101 953-1-1 V1.1.1 (2002-11)	Access and Terminals (AT); Unified and Generic Testing Methods for European Specific DSL splitters; Part 1: ADSL splitters for European deployment; Sub-part 1: Specification of Testing methods for Low Pass part of ADSL/POTS splitters

	Publication	Title
	ITU-T and CCITT Recommendations	
[9]	G.122 (03/93)	Influence of national systems on stability, talker echo, and listener echo in international connections
[10]	G.992.5 (01/05)	Asymmetric Digital Subscriber Line (ADSL) transceivers - Extended bandwidth ADSL2 (ADSL2plus)
[11]	O.9 (03/99)	Measuring arrangements to assess the degree of unbalance about earth
[12]	O.41 (10/94)	Psophometer for use on telephone-type circuits
[13]	O.42 (11/88)	Equipment to measure non-linear distortion using the 4-tone method

4 ABBREVIATIONS AND DEFINITIONS

For the purposes of this Standard, the following abbreviations and definitions and those of Part 1 apply:

4.1 Abbreviations

ACA	Australian Communications Authority
ACIF	Australian Communications Industry Forum
ACMA	Australian Communications and Media Authority
ADSL	Asymmetric Digital Subscriber Line
AS	Australian Standard
CE	Customer Equipment
DC	Direct Current
DSL	Digital Subscriber Line
DUT	Device under test
ITU-T	International Telecommunications Union – Telecommunications
LCL	Longitudinal Conversion Loss
LCTL	Longitudinal Conversion Transfer Loss
PE	Protective Earth
PSTN	Public Switched Telephone Network
SI	International System
TN12	Termination Network 12
TRC	Telecommunications Reference Conductor
VDSL	Very high speed Digital Subscriber Line
VF	Voice Frequency

4.2 Definitions

4.2.1 Carrier

Refer to the *Telecommunications Act 1997*.

4.2.2 Carriage Service Provider

Refer to the *Telecommunications Act 1997*.

4.2.3 Centralised Filter (Master Splitters)

Centralised filters are typically three port devices, designed to be located and hard-wired at a central point in the customer premises (often the carrier demarcation point) from which all Voiceband PSTN CE cabling radiates, providing separation of PSTN and ADSL signals at a single location.

Note 1: Figure 15(b) shows how the Centralised filter is used to isolate the DSL functions from the PSTN CE.

Note 2: The parallel connection to the Metallic Local Loop of a centralised filter with any other filter (inline or centralised) is not recommended.

4.2.4 Customer Equipment

Refer to the *Telecommunications Act 1997*.

4.2.5 Distributed Filters ('in-line' filters or 'micro-filters')

Distributed filters are functionally two port devices, optionally provided with a third port for modem connection, allowing for self installation by the end user in series with each item of Voiceband PSTN CE.

Note 1: Multiple Distributed Filters will typically be used in a customer premises as ADSL signals are delivered over the entire premises wiring.

Note 2: The Distributed Filters specified by the current document are only intended to be connected individually in series with the PSTN CE. Operation is not specified for stacking (i.e. connecting one Distributed Filter in series with another Filter of any type).

Note 3: Figure 15(a) shows how the distributed filter is used to isolate the DSL functions from the PSTN CE.

Note 4: The parallel connection to the Metallic Local Loop of distributed filters with a centralised filter is not recommended.

4.2.6 Facility

Refer to Section 374(2) of the *Telecommunications Act 1997*.

4.2.7 Line Port

A port on CE for connection to the Metallic Local Loop.

4.2.8 Line Terminating Equipment

Line terminating equipment incorporates circuitry that applies an online condition to the PSTN line. CE incorporating this functionality may be associated with the line as—

- (a) the only line terminating equipment connected to a line, to provide the sole termination of that line; or
- (b) one or more parallel items of line terminating equipment, one or all of which can be used to terminate the line; or
- (c) one of a number of items of line terminating equipment, which can be used alternatively to terminate the line, e.g. for alternative voice/data applications.

4.2.9 Local Port

A port on series CE for connection of other CE.

- 4.2.10 Metallic local loop
Metallic twisted pair communications wire in a carrier's network that provides connectivity between a customer's premises and equipment in a Telecommunications Network.
- 4.2.11 Off-line
The state of the Line Terminating Equipment when it has an electrical configuration that causes the current in the basic network loop to be at its minimum steady-state value. Can also be described as 'on hook'.
- 4.2.12 Off-hook
See On-line.
- 4.2.13 On-line
The state of the Line Terminating Equipment when it has an electrical configuration that causes the current in the basic network loop to be at its maximum steady-state value. Can also be described as 'off-hook'.
- 4.2.14 On-hook
See Off-line
- 4.2.15 Public Switched Telephone Network (PSTN)
That part of the Telecommunications Network which enables any customer to establish a connection for voice frequency communication with any other customer either automatically or with operator assistance.

Note: The PSTN has a nominal transmission bandwidth of 3 kHz.
- 4.2.16 Standard Telephone Service
Refer to Section 6 of the *Telecommunications (Consumer Protection and Service Standards) Act 1999*.

Note: ACIF G534 [5] provides guidance on the application of the standard telephone service definition.
- 4.2.17 Telecommunications Network
Refer to Section 374(1) of the *Telecommunications Act 1997*.
- 4.2.18 Telecommunications Reference Conductor (TRC)
A low noise earthing system providing a zero voltage reference point for telecommunications signalling and other functional purposes which may include equipment reliability.
- 4.2.19 Voice Frequency (VF)
Those frequencies in the range of 300 Hz to 3.4 kHz.

4.2.20 Voiceband

Voiceband is a general term that may include frequencies from 200 Hz to 4.0 kHz.

5 REQUIREMENTS

5.1 General

5.1.1 Filters used in conjunction with all ADSL services

Part 3 of this Standard lists specific requirements that apply to CE that perform the function of an ADSL filter, for connection to any ADSL (ADSL1), ADSL2 and ADSL2+ service. General requirements are covered in Part 1 of this Standard.

5.1.2 Provision of advice on the suitability of the device

Due to the potential for increased interference on higher speed ADSL services (e.g. ADSL2+), the level of protection provided by some filters manufactured to previous Standards may not be as great as that provided by this Standard. This Standard provides the latest requirements for filters in interference protection. Filters that comply with the requirements in this Standard **shall** be provided with a suitable advisory notice to differentiate them from those that comply with previous Standards.

Note: Any advisory notice should be legible and placed in a readily visible position, e.g. placed on the CE, on the CE packaging or in the User Instructions.

For the information of manufacturers and suppliers of ADSL filters, a form of advice recommended for inclusion on the filter's packaging to advise potential users of the compatibility of the filter with the ADSL service provided, is shown below.

**THIS ADSL FILTER IS COMPLIANT TO AS/ACIF S041:2009
AND IS SUITABLE FOR ALL ADSL SERVICES INCLUDING ADSL2+**

5.2 Filter types

5.2.1 General

The following requirements apply to CE which is—

- (a) an ADSL filter, or
- (b) part of a CE that has an ADSL filter function for connection on a carrier access line to which both PSTN CE and ADSL modem equipment are connected.

A primary function of an ADSL over PSTN filter is to protect the Voiceband PSTN CE from interference from the ADSL signals. It also protects the ADSL transmission from signalling transients generated during ring, ring trip, dialling, etc. and also prevents interference to the ADSL service due to change in impedance and linearity that occur when Voiceband PSTN CE changes operational state (e.g. from off hook to on hook).

The transfer function between the LOCAL port and LINE port (and vice versa) of each filter is that of a low pass filter. The DSL modem connected to the MODEM port incorporates the high pass filter function.

5.2.2 Distributed Filters ('in-line' filters or 'micro-filters')

Distributed Filters are to comply with the requirements of this Standard in configurations of 1, 2 and 3 filters connected to line in parallel, where one filter is terminated in an on-line state, and the other filters are in an off-line state as shown in Figures 7(a) to 12(a). Each off line filter is terminated by a Z_{ON} network as shown in Figure 1(c).

In recognition of the increasing complexity of customer PSTN services, distributed filters should comply with the requirements of this Standard in configurations of up to five filters inclusive, connected to line where one is in an on-line state and four of the filters are in the off-line state as described above.

5.2.3 Centralised Filter (Master Splitters)

Centralised filters need to comply with the requirements of this Standard including in the configurations shown in Figures 7(b) to 12(b). Centralised filters do not have defined on-line and off-line states, always being in an active mode. All off-line measurements are however, performed with a Z_{on} termination. Only a single filter is to be tested in the configurations of Figures 4 and 5.

5.2.4 Distributed and centralised filter labelling

Due to the potential performance degradation from incorrect usage of some filters, ADSL filters incorporating modular connectors (such as RJ-11 or RJ-45) **shall** have appropriately worded identification included on the filter, packaging and documentation to identify the type of filter (Central or In-line) and therefore to advise potential users/installers of their suitability for installation.

For a distributed filter described under Clause 5.2.2, that identification should include one of the following terms: 'distributed filter', 'in-line filter', 'micro-filter', 'distributed splitter', 'in-line splitter' or 'micro-splitter'.

For a centralised filter described under Clause 5.2.3, that identification should include one of the following terms: 'centralised filter', 'central filter', 'master filter', 'centralised splitter', 'central splitter' or 'master splitter'.

5.3 Technical Requirements

5.3.1 Home networking

Where the filter is to be used with high frequency services such as home networking signals or VDSL, the requirements of this Standard should be met up to 32 MHz.

5.3.2 DC current range

On-line electrical requirements of ADSL filters **shall** be met with a DC line current over the range of 15 mA to 80 mA.

It is recommended that the ADSL filter On-line electrical requirement should be met with a loop current of up to 120 mA d.c.

5.3.3 Reference Impedance

Unless specified, the reference impedance **shall** be TN12 or Z_r . The European harmonized impedance Z_r is a close match to the Australian complex impedance TN12. Suppliers should nominate which reference impedance is to be used for compliance testing.

5.3.4 Test Impedances

Figure 1 illustrates the various impedance networks to be used for providing terminations in testing for compliance with this Standard.

Figure 1 (a) illustrates the VF terminations that are used, these being:

- (a) TN12 Australian complex impedance for Voiceband CE.
- (b) Z_r European Harmonized impedance for Voiceband CE.
- (c) Z_{sl} Short line impedance as would be encountered with a 600 Ω PSTN exchange.

Figure 1 (b) illustrates the equivalent circuit of the ADSL modem CE (ATU-R).

Figure 1 (c) illustrates the equivalent circuit of a single terminating CE (e.g. a line powered telephone) in the on hook state at VF and DSL signal amplitudes.

Figure 1 (d) illustrates a wideband termination network that provides 120 Ω termination at high frequencies and a modified complex impedance at Voiceband frequencies.

5.3.5 DC series resistance

5.3.5.1 CE with linear electrical characteristics **shall** have a maximum total DC resistance of 50 Ω .

5.3.5.2 For distributed CE with non-linear electrical characteristics, the total DC voltage drop across the line connections **shall not** exceed—

- (a) 3.0 V for line currents up to and equal to 30 mA; and
- (b) 5.0 V for line currents in the range 30 mA to 80 mA.

5.3.5.3 For centralised CE with non-linear electrical characteristics, the total DC voltage drop across the line connections **shall not** exceed—

- (a) 2.0 V for line currents up to and equal to 30 mA; and
- (b) 4.0 V for line currents in the range 30 mA to 80 mA.

Compliance with Clause 5.3.5 should be checked by measuring the DC resistance and the DC voltage drop, as appropriate.

5.3.6 Ringing voltage drop

CE in the Off-line state **shall not** have a ringing voltage drop of more than 2 V r.m.s. over the frequency range 18 to 28 Hz.

Compliance with Clause 5.3.6 can be verified by the procedure indicated in Clause 6.5.1.2.

5.3.7 Return loss

(a) An ADSL filter CE **shall** have a Return Loss of greater than or equal to the limits specified in Table 1 when measured—

(i) at the ports indicated in Table 1;

(ii) using the same Reference and Termination impedance;

(iii) both with and without Z_{dsl} connected; and

(iv) over the 15 mA to 80 mA on-line loop current range.

(b) ADSL filter CE should have a return loss of greater than 14 dB within the frequency band 300 to 3400 Hz and greater than 8 dB within the frequency band 3.4 kHz to 10 kHz inclusive.

Compliance with Clause 5.3.7 can be verified by the procedure indicated in Clause 6.5.2.

5.3.8 Unbalance about Earth

The balance of DSL filters measured as:

(a) A longitudinal conversion loss (LCL) at the line port, with S1 both open and closed, **shall** be no less than the LCL Limits shown in Table 2. See Figure 3(a).

(b) A longitudinal conversion transfer loss (LCTL) from the local port to the line port **shall** be no less than the LCL Limits shown in Table 2. See Figure 3(b).

(c) A longitudinal conversion loss (LCL) at the local port, with S1 both open and closed, should be no less than the LCL Limits shown in Table 2. See Figure 3(c).

Compliance with Clause 5.3.8 can be demonstrated by the method described in Clause 6.5.3.

TABLE 1
ADSL filter return loss

Measurement port	Measurement reference (Note 1)	Termination port	Termination impedance (Note 1)	Frequency band (Hz)	Limit (dB)
Line	TN12 or Z_r	Local	TN12 or Z_r	300 to 3400	12
Line	TN12 or Z_r	Local	TN12 or Z_r	3400 to 4000	8
Local	TN12 or Z_r	Line	TN12 or Z_r	300 to 3400	12
Local	TN12 or Z_r	Line	TN12 or Z_r	3400 to 4000	8
Local	Z_{sl}	Line	Z_{sl}	300 to 3400	12
Local	Z_{sl}	Line	Z_{sl}	3400 to 4000	8

Note 1: The terminations of TN12, Z_r and Z_{sl} are shown in Figure 1.

Note 2: The Line to Local configuration for a distributed filter CE is given in Figure 7(a).

Note 3: The Line to Local configuration for a centralised splitter filter CE is given in Figure 7(b).

TABLE 2
DSL filter balance

R1 to R4 (Ω)	R5 (Ω)	Frequency band	LCL Limit (dB)
300	0	50 Hz to 600 Hz	46
300	0	600 Hz to 3400 Hz	52
300	0	3400 Hz to 4000 Hz	46
50	150	4.0 kHz to 30 kHz	40
50	150	30 kHz to 140 kHz	45
50	150	140 kHz to 2208 kHz	50
50	150	2208 kHz to 5.0 MHz	30

Note: The values for R1 to R5 refer to those shown in Figures 3(a), 3(b) and 3(c).

5.3.9 Group Delay Distortion

The increase of group delay (i.e. the Group Delay Distortion) of one splitter is determined relative to the lowest measured delay in the frequency range 300 Hz to 4 kHz. The Group Delay Distortion **shall not** exceed the limits in Table 3.

TABLE 3
Group delay distortion

Frequency band (Hz)	Limit (μ s)
200 to 600	250
600 to 3200	200
3200 to 4000	250

Compliance with Clause 5.3.9 should be checked in the configuration of Figure 8.

5.3.10 Voiceband Filter Loss 'On-Line'

The filter loss of CE **shall** be in the range of 0 to 1.0 dB at 1 kHz in each direction for source and load reference impedance as specified in Clause 5.3.3, being the same reference impedance chosen in Clause 5.3.7, both with, and without Z_{dsl} connected.

Compliance with Clause 5.3.10 should be checked by measuring the filter loss as follows:

- (a) For filter CE of the distributed type, by either—
 - (i) the method specified in Clause 6.5.4; or
 - (ii) the method specified for measuring pass band insertion loss in ETSI TS 101 952-1-5 [7].
- (b) For filter CE of the centralized type, by either—
 - (i) the method specified in Clause 6.5.4; or
 - (ii) the method specified for measuring Insertion Loss in the Pass Band in ETSI TR 101 953-1-1 [8].

The same test method is to be selected for both Clauses 5.3.10 and 5.3.11, with the test method specified by ETSI being the preferred test method. The test method specified in Clause 6.5.4 is the subject for further review for future removal from the Standard.

5.3.11 Voice Band Filter Loss distortion 'On-Line'

The absolute difference between the filter loss at any frequency in the range 200 Hz to 4000 Hz and the filter loss at 1 kHz **shall** be no greater than—

- (a) 1.0 dB for a single filter; and
- (b) 1.5 dB for two and three filters,

in each direction and for source and load reference impedance specified in Clause 5.3.3, both with, and without Z_{dsl} connected.

Compliance with Clause 5.3.11 should be checked by measuring the filter loss distortion as follows:

- (a) For filter CE of the distributed type, by either—
 - (i) the method specified in Clause 6.5.4; or
 - (ii) the method specified for measuring pass band insertion loss in ETSI TS 101 952-1-5 [7].
- (b) For filter CE of the centralized type, by either—
 - (i) the method specified in Clause 6.5.4; or
 - (ii) the method specified for measuring Insertion Loss Distortion in the Pass Band in ETSI TS 101 953-1-1 [8].

The same test method is to be selected for both Clauses 5.3.10 and 5.3.11, with the test method specified by ETSI being the preferred test method. The test method specified in Clause 6.5.4 is the subject for further review for future removal from the Standard.

5.3.12 Voiceband Filter Loss 'Off-line'

The voltage loss of CE should be within the range -4 dB to $+4$ dB over the range 200 to 2800 Hz, for 600 Ω source and 10 k Ω load impedances, both with, and without Z_{ds1} connected.

Testing is to be performed using a -4 dBV test signal level.

Compliance with Clause 5.3.12 should be checked by measuring the Filter loss in the configuration of Figures 10(a) or 10(b), as appropriate.

5.3.13 Intermodulation distortion

Using reference impedance specified in Subclause 5.3.3 and the 4-tone method detailed in ITU-T Rec. O.42 [13], at a level of -9 dBm, the second and third order Harmonic distortion product **shall** be at least 57 dB and 60 dB, respectively below the received signal level.

The second and third order harmonics of the 4-tone signal are measured at the Local port.

Compliance with Clause 5.3.13 should be checked in the configuration of Figures 11(a) or 11(b), as appropriate.

5.3.14 ADSL band filter loss On-line state

- 5.3.14.1 An individual filter in the On-line state **shall** comply with either of the loss requirements under the conditions set out in Table 4.

TABLE 4
Loss requirements in the On-line state

Frequency (kHz)	Loss (dB)	Source & Load	DC Loop (mA)
$32 \leq f \leq 2208$	> 55	120 Ω	$15 \leq I \leq 80$
$32 \leq f \leq 2208$	> 55	Z_{RHF}	$15 \leq I \leq 80$

- 5.3.14.2 An individual filter in the On-line state should comply with either of the loss requirements under the conditions set out in Table 5.

TABLE 5
Recommended loss in the On-line state

Frequency (kHz)	Loss (dB)	Source & Load	DC Loop (mA)
$32 \leq f \leq 2208$	> 55	120 Ω	$80 \leq I \leq 120$
$32 \leq f \leq 2208$	> 55	Z_{RHF}	$80 \leq I \leq 120$

- 5.3.14.3 Filter loss is defined as $20 \log (V_1/V_2)$ where V_1 is the voltage at the Line port of the CE and V_2 is the voltage at the load at the local port.

While Figure 12 provides the configuration for this test, ETSI TR 101 953-1-1 [8] offers a different test configuration for centralised filters. For ADSL band filter loss (isolation), either method can be used to verify compliance.

Compliance with Clause 5.3.14 should be checked in the configuration of Figures 12(a) or 12(b), as appropriate.

- 5.3.15 ADSL band filter loss Off-line state

An individual filter in the Off-line state **shall** comply with the loss requirements under the conditions set out in either Table 6 or Table 7.

Testing is to be performed using a -6 dBV test signal level.

Filter loss is defined as $20 \log (V_1/V_2)$ where V_1 is the voltage at the Line port of the CE and V_2 is the voltage at the load at the local port.

Compliance with Clause 5.3.15 should be checked in the configuration of Figures 12(a) or 12(b), with the DC loop replaced by Z_{ON} termination.

TABLE 6
Loss in the Off-line state with a 120 Ω Source

Frequency (kHz)	Loss (dB)	Source (Ω)	Load
$32 \leq f \leq 350$	> 34	120	Z_{ON}
$350 \leq f \leq 2208$	> 55	120	Z_{ON}

TABLE 7

Loss in the Off-line state with a Z_{RHF} Source

Frequency (kHz)	Loss (dB)	Source	Load
$32 \leq f \leq 350$	> 34	Z_{RHF}	Z_{ON}
$350 \leq f \leq 2208$	> 55	Z_{RHF}	Z_{ON}

5.3.16 LINE Port impedance Offline state

The low pass filter CE in the Offline state **shall** present a modulus of impedance to the Line port of at least 1 k Ω over the frequency range specified in Table 8.

TABLE 8

Line Port Impedance in the Off Line State

Number of Filters	Frequency band (kHz)	Minimum Impedance (k Ω)
1	32 to 2208	1
2	64 to 2208	1
3	64 to 2208	1

This requirement applies with the Local port terminated in either 120 Ω or Z_{RHF} .

5.3.17 Noise in Voiceband

Mean noise power for EACH configuration comprising one, two and three filters **shall not** exceed:

- (a) -75 dBmp using a testing device compliant with ITU-T Rec. O.41 [12] measured across a 600 Ω termination.
- (b) -50 dBm (unweighted), measured using a device with a uniform frequency response over the range 30 Hz to 20 kHz measured across a 600 Ω termination.
- (c) -60 dBm at any single frequency over the range 30 Hz to 20 kHz, measured selectively with a 30 Hz bandwidth measured across a 600 Ω termination.
- (d) -62 dBmp measured across a 600 Ω termination and using a testing device compliant to ITU-T Rec. O.41 [12] where the CE is used in conjunction with an ADSL2+ modem and the ADSL2+ modem—
 - (i) is compliant with—
 - (1) ITU-T Rec. G.992.5 [10];

- (2) the group B requirements of Equipment Class 6h of AS/ACIF S043.2 [4]; and
 - (3) AS/ACIF S041.2, Part 2 of this Standard; and
- (ii) is—
- (1) in an active state in the ADSL2+ mode, excluding transient start up or initialisation phases, and
 - (2) transmitting in the R-MEDLEY state for a sufficient period of time that will allow a stable psophometer measurement to be performed.

Note: R-MEDLEY state is a minimum power of +12.5 dBm as defined in G.992.5 [10].

Compliance with Clause 5.3.17 may be verified using the configuration of Figures 4 and 5.

5.3.18 Noise in ADSL band

The noise in the frequency range 26 kHz to 2208 kHz measured at the line port of filter CE **shall** be less than -140 dBm/Hz in a bandwidth of 10 kHz.

Compliance with Clause 5.3.18 may be verified using the configuration of Figure 13.

5.3.19 PSTN transient effects

Transient effects measured at the Line port of the filter should be less than 2 V peak-to-peak and the main lobe of the Fourier Transform of the transient should have its peak at a frequency less than 15 kHz when step loads are applied in either direction at the Local port.

For central and inline filters, POTS signalling events such as seize and clear and ring trip can cause impulse noise in the ADSL2+ band. While the specified isolation in the ADSL2+ band should ensure a level of protection for the ADSL2+/ADSL2/ADSL services, any design feature that causes a degradation in that critical impulse noise performance (e.g. one that resulted in further nonlinearity when such signalling events occur) would be unacceptable.

For inline filters, the switch that changes the impedance of the filter in the POTS band when the telephone is taken off-hook (offline to online transition) or placed on-hook (online to offline transition) should not significantly change the impedance seen from the line side at ADSL2+ frequencies. For ADSL2+/ADSL2/ADSL systems with up to 15 bit constellations, a change of 0.2% (i.e. 50 k Ω in parallel with 100 ohm) can have a serious impact on error performance and a change of 1% (10 k Ω in parallel with 100 Ω) ensures an immediate failure of the ADSL2+/ADSL2/ADSL. The introduction of any other form of nonlinearity or time varying channel characteristic in the ADSL2+ band could also cause similar degradation in performance and instability.

Compliance with Clause 5.3.19 may be verified as described in Clause 6.5.7.

5.3.20 Parallel operation

To ensure that the DC characteristics of distributed filter CE will allow for handover between parallel connected CE, the filter should not block DC loop currents to the local port for a voltage ≥ 6 V dc at the line port.

Compliance with Clause 5.3.20 may be verified as described in Clause 6.5.8.

6 TESTING

6.1 Verification of compliance with requirements

Compliance with all mandatory requirements in this AS/ACIF Standard is to be verified. This may be done by direct measurement, modelling and analysis, operation or inspection.

Methods for demonstrating compliance of CE with the requirements clauses specified in this Standard are described in Clauses 6.2 to 6.5.

Alternative methods of demonstrating compliance to those described may be used if the risk of passing non-compliant CE is not increased because of increased measurement uncertainty.

6.2 Standard test conditions

6.2.1 Unless this Standard provides otherwise, testing for compliance with this Standard should be conducted at the nominal supply voltage of the CE and within the following ranges of atmospheric conditions:

- (a) An ambient temperature in the range of 15°C to 25°C inclusive.
- (b) A relative humidity in the range of 45% to 75% inclusive.
- (c) An air pressure in the range of 86 kPa to 106 kPa inclusive.

6.2.2 Where elements in a test configuration are variable, the test should be carried out over the indicated range for that element.

6.2.3 Unless indicated elsewhere within this Standard—

- (a) the accuracy level of all measurements should be better than $\pm 2\%$ for voltage and current, $\pm 0.25\%$ for frequency and $\pm 0.5\%$ for time; and
- (b) the tolerance of the nominal 48 V d.c. test source should be ± 0.5 V.

6.2.4 Unless indicated elsewhere within this Standard for an individual test, all component values in the test configuration should have a tolerance of—

- (a) $\pm 1\%$ for resistance;
- (b) $\pm 1\%$ for capacitance; and
- (c) -0% , $+25\%$ for inductors.

6.2.5 D.C. excitation

6.2.5.1 Figures 7 to 13 show provision for DC feed, and DC loop connections. The components for these circuits, and the associated coupling capacitors, are to be chosen to ensure that negligible impact on Voiceband and DSL band measurement results are caused by these connections.

- 6.2.5.2 On-line DC conditions are a loop current adjustable over a 15 mA to 80 mA range.
- 6.2.5.3 For CE that senses an unlooped state, the Off-line DC condition is an applied voltage of 36 ± 0.5 V dc.
- 6.2.6 For DSL band loss, measurements can be made with either 120Ω or Z_{RHF} source and load terminations.

6.3 Levels

Unless otherwise specified, tests should be carried out with a send level of -10 dBV for VF signals.

6.4 Test frequencies

Test frequencies should be in the range of 300 Hz to 4 kHz unless otherwise specified in the relevant requirement clauses of this Standard. Sufficient measurements should be carried out around all nodal points of relevant masks, where applicable.

6.5 Parameters to be tested

6.5.1 Ringing characteristics

6.5.1.1 Impedance

The impedance of DSL products that are interfaced to a PSTN subscriber line should be measured in the configuration of Figure 2 with switch S1 operated and the impedance calculated from the voltage dropped across the $1.2 \text{ k}\Omega$ resistor.

6.5.1.2 Insertion Loss

Ringing Voltage drop of DSL filters, should be measured in the configuration of Figure 2 with the appropriate load for the type of filter connected across M1. The insertion loss is the difference in the readings at M1 with both S₁ and S₂ as shown, and with both S₁ and S₂ operated.

6.5.2 Return loss

The return loss, as defined in Annex B of ITU-T Rec. G.122 [9], should be measured by a suitable bridge circuit or a vector impedance meter as shown in Figure 7 using a test level of -10 dBm.

6.5.3 Impedance balance

Impedance balance is defined as the ratio U/V measured as shown in Figure 3. The test should be carried out by injecting a signal of 3 V r.m.s. between the earth and the midpoint of two resistors connected in series, in accordance with ITU-T Rec. O.9 [11]. Earth should be either TRC or protective earth termination, or both.

A two port device (i.e. filter) is tested with a pair of resistors on each port, the port not being measured having provision to connect the midpoint to earth.

Measurements are to be performed during both the offline and online states in conjunction with the DC conditions specified in Clause 5.3.2.

CE without an earth connection should be placed on an earthed metal plate of sufficient size.

Note: Impedance balance = $20 \log (U/V)$ dB.

6.5.4 Filter loss

Filter loss should be measured as shown in the test circuit of Figure 9 or Figure 10 as appropriate.

Testing should be performed using a -10 dBm test signal level and Complex Impedance (TN12)/ Z_r source and load.

The filter loss is given by

$$\text{Filter loss} = 20 \log (V_1/V_2) \text{ dB.}$$

Where V_1 = Voltage at the port connected to the source

V_2 = Voltage at the port connected to the load.

6.5.5 Noise performance

6.5.5.3 The following types of noise should be measured—

- (a) Psophometric;
- (b) Unweighted; and
- (c) Single frequency.

6.5.5.4 Depending on the type of noise, appropriate noise measurement equipment should be used as shown in the test circuit of Figure 4 or Figure 5.

6.5.6 Signal levels and frequencies

Signal levels and frequencies should be measured as shown in Figure 4 or 5 using a selective level meter, psophometer or spectrum analyser with appropriate input dynamic range and frequency range. When used to measure the levels of individual frequency components, bandwidths of 3 Hz, 10 Hz, 30 Hz and 100 Hz may be used as appropriate.

6.5.7 Test for POTS Transient effects

The test configuration is shown in Figure 6. The switch is operated and released in turn, the resultant signals being observed on the FFT. The recommended requirements of Clause 5.3.19 should be satisfied.

6.5.8 Parallel Handover

Parallel Handover can be verified by a current of ≥ 10 mA flowing in the configuration of Figure 14.

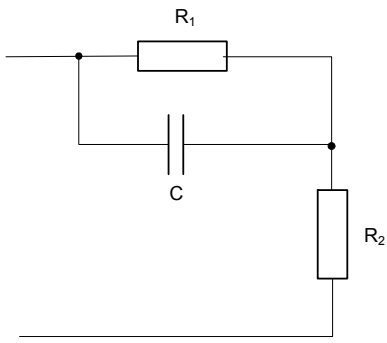

Load	Component Values
TN12	$R_1 = 820 \Omega \pm 0.1\%$ $R_2 = 220 \Omega \pm 0.1\%$ $C = 115 \text{ nF or } 120 \text{ nF} \pm 0.1\%$
Z_r	$R_1 = 750 \Omega \pm 0.1\%$ $R_2 = 270 \Omega \pm 0.1\%$ $C = 150 \text{ nF} \pm 0.1\%$
Z_{sl}	$R_1 = 600 \Omega \pm 0.1\%$ $R_2 = 82 \Omega \pm 0.1\%$ $C = 68 \text{ nF} \pm 0.1\%$

Voice frequency networks
Figure 1(a)

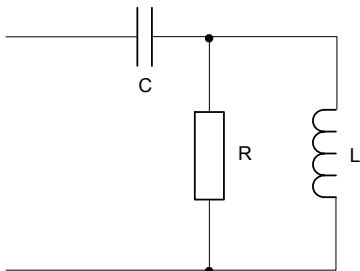

Load	Component Values
Z_{DSL}	$R = 100 \Omega \pm 1\%$ $C = 27 \text{ nF} \pm 1\%$ $L = 470 \mu\text{H} \pm 1\%$

DSL frequency network
Figure 1(b)

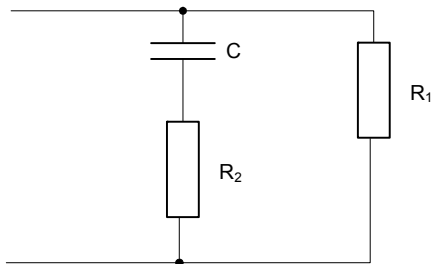

Load	Component Values
Z_{ON}	$R_1 = 1 \text{ M}\Omega \pm 1\%$ $R_2 = 10 \text{ k}\Omega \pm 1\%$ $C = 1 \mu\text{F} \pm 1\%$

On-hook termination network
Figure 1(c)

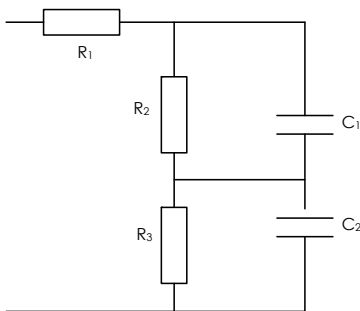

Load	Component Values
Z_{RHF}	$R_1 = 120 \Omega \pm 0.1\%$ $R_2 = 150 \Omega \pm 0.1\%$ $R_3 = 750 \Omega \pm 0.1\%$ $C_1 = 47 \text{ nF} \pm 0.1\%$ $C_2 = 150 \text{ nF} \pm 0.1\%$

Wideband termination network
Figure 1(d)

FIGURE 1
Reference impedances

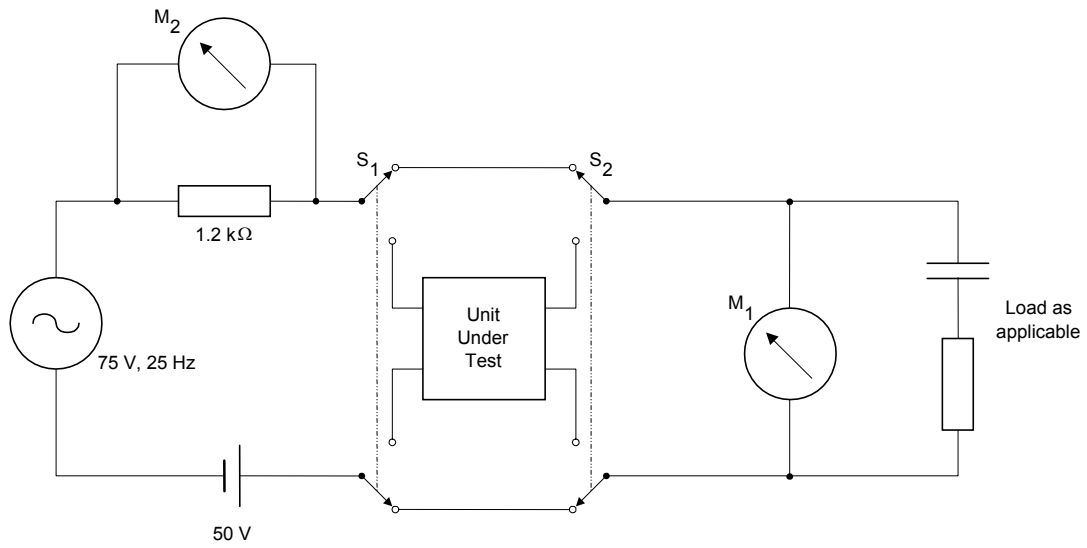

- Test method 1 Ring insertion loss
 Note reading at meter M_1
 Operate both switches S_1 and S_2
 Note second reading at meter M_1
 Subtract second reading from the first
- Test method 2 Ring Impedance
 Operate switch S_1
 Measure volts dropped at M_2
 Calculate current in $1.2 \text{ k}\Omega$
 Calculate resistance of Unit Under Test

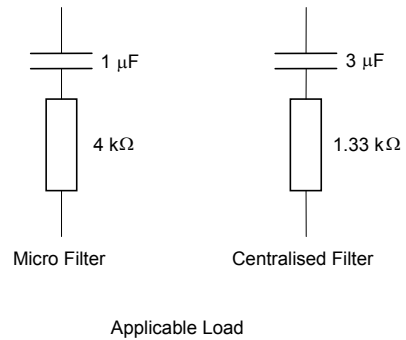

FIGURE 2
Test circuit for ring characteristics of xDSL filters

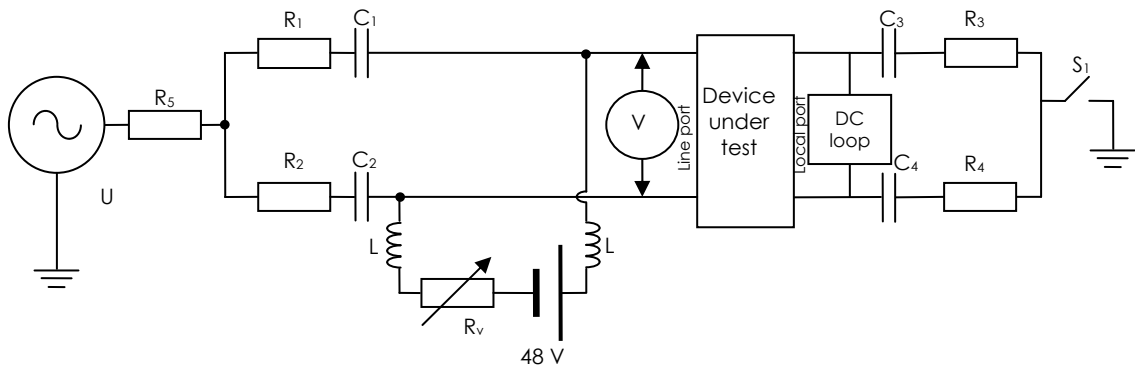

Figure 3(a) Test for xDSL filter balance about earth at the line port

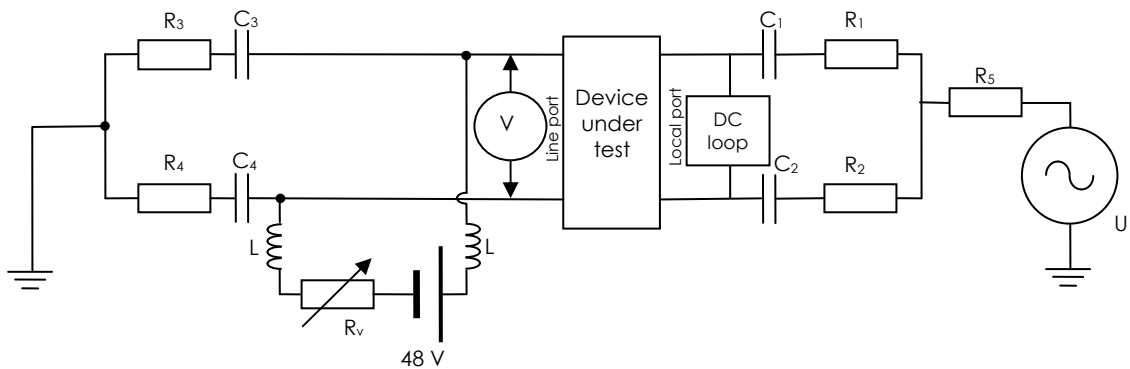

Figure 3(b) Test for xDSL filter balance about earth from the local port to the line port

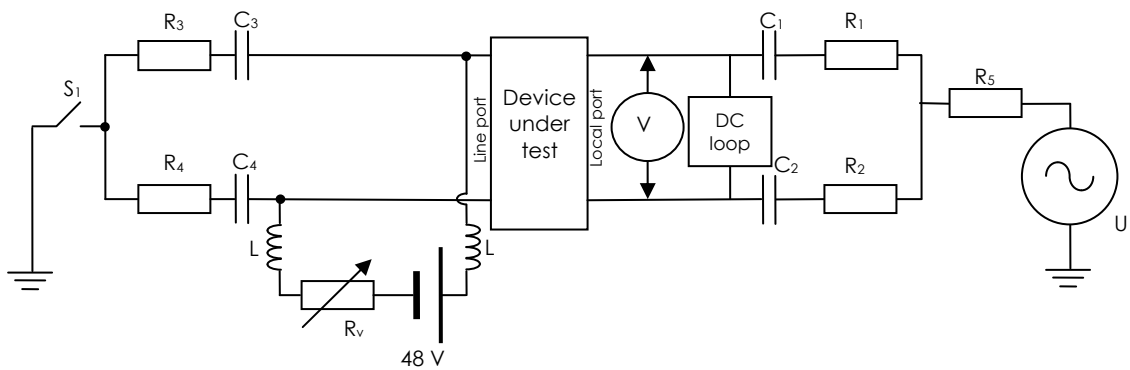
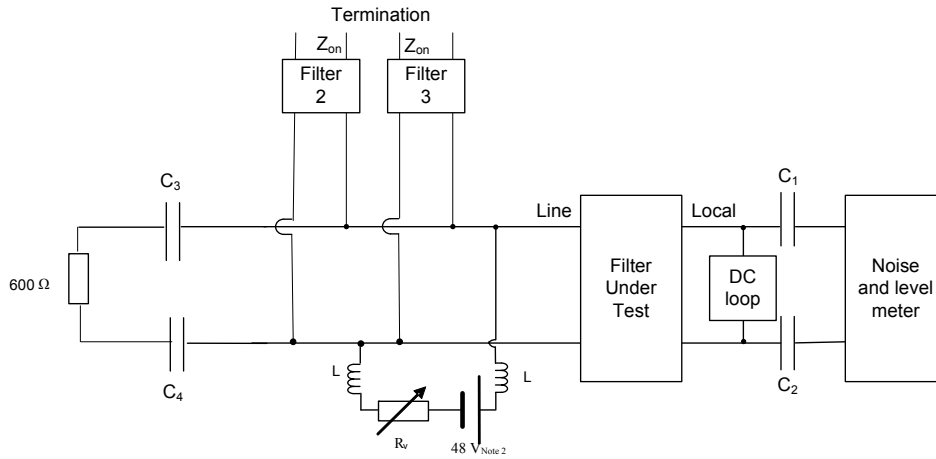

Figure 3(c) Test for xDSL filter balance about earth at the local port

<p>Note 1:</p>	<p>All measurements to accuracy better than: $\pm 2\%$ Voltage and current $\pm 0.5\%$ time $\pm 0.25\%$ frequency $\pm 0.2\text{dB}$ power level</p>	<p>$L \geq 10\text{ H}$ for up to 125 mA d.c. over the range 100 Hz to 4000 Hz. For frequencies above 4000 Hz, a high frequency feedbridge will be required that has a loading effect $\leq 0.1\text{ dB}$. Feedbridge LCL shall be at least 20 dB better than the values in Table 2. $C_1 > 100\ \mu\text{F}$ $C_3 > 100\ \mu\text{F}$ $C_2 > 100\ \mu\text{F}$ $C_4 > 100\ \mu\text{F}$</p>
<p>Note 2:</p>	<p>C_3, R_3, C_4, R_4 and the DC loop are required for a two port device.</p>	<p>$C_1 - C_2 < \pm 0.01\ C_1$ $C_3 - C_4 < \pm 0.01\ C_3$ R_1, R_2, R_3 and $R_4 = 300$ (or 50) Ω R_1 to $R_4 - \pm 0.1\ \Omega$ $R_5 = 0$ or 150 Ω (includes the source impedance of U) $R_v = 400$ to 2300 Ω (includes resistance of 2 L)</p>

FIGURE 3

Test for xDSL filter balance about earth



<p>Note 1:</p>	<p>All measurements to accuracy better than: $\pm 2\%$ Voltage and current $\pm 0.5\%$ time $\pm 0.25\%$ frequency $\pm 0.2\text{dB}$ power level</p>	<p>$L \geq 10 \text{ H}$ for up to 125 mA d.c. over the range 100 Hz to 4000 Hz $C_1 > 100 \mu\text{F}$ $C_2 > 100 \mu\text{F}$ $R_v = 400 \text{ to } 2300 \Omega$ (includes resistance of 2 L)</p>
<p>Note 2:</p>	<p>The selective level meter should have a bandwidth of 10 Hz +/- 30% at its 3 dB points</p>	

FIGURE 4

Noise measurements psophometric, single frequency and unweighted

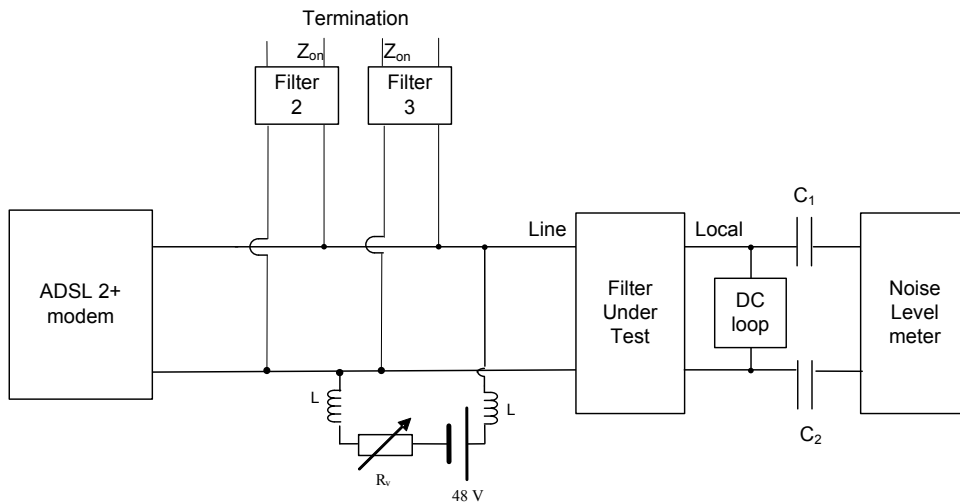

<p>Note 1:</p>	<p>All measurements to accuracy better than: $\pm 2\%$ Voltage and current $\pm 0.5\%$ time $\pm 0.25\%$ frequency $\pm 0.2\text{dB}$ power level</p>	<p>$L \geq 10 \text{ H}$ for up to 125 mA d.c. over the range 100 Hz to 4000 Hz $C_1 > 100 \mu\text{F}$ $C_2 > 100 \mu\text{F}$ $R_v = 400 \text{ to } 2300 \Omega$ (includes resistance of 2 L)</p>

FIGURE 5

Psophometric noise measurements

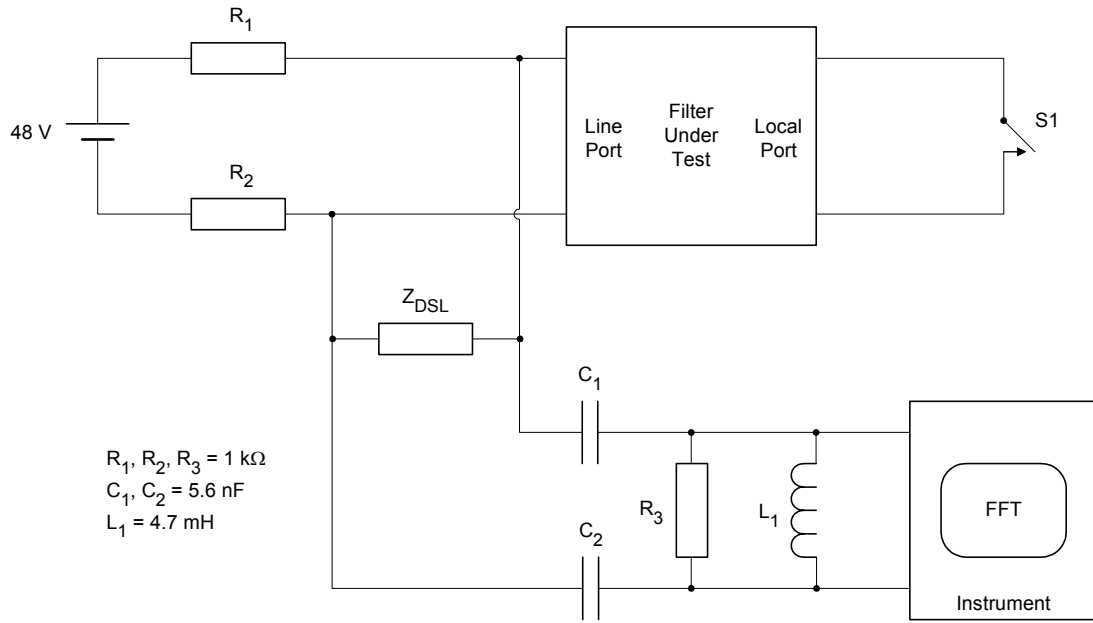
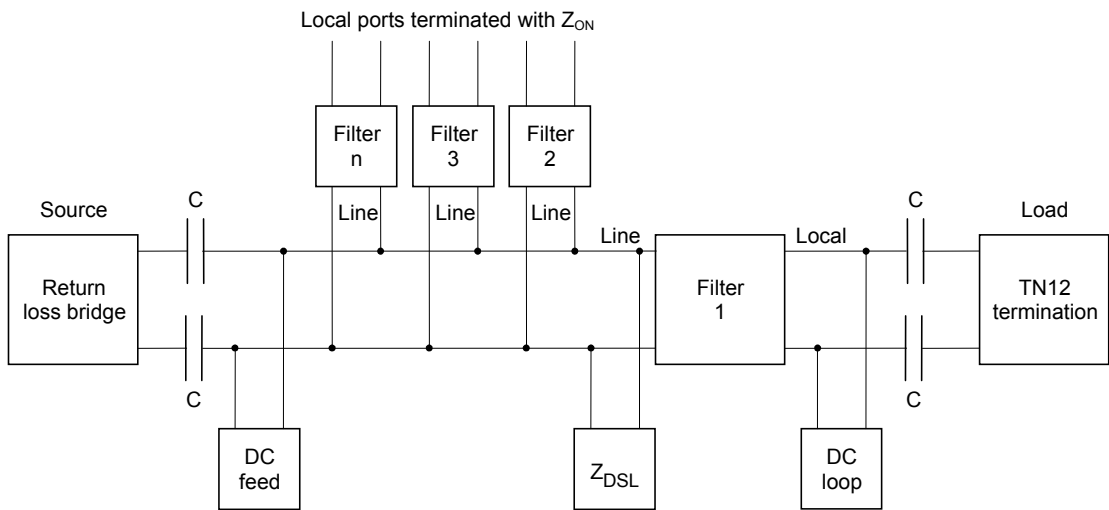
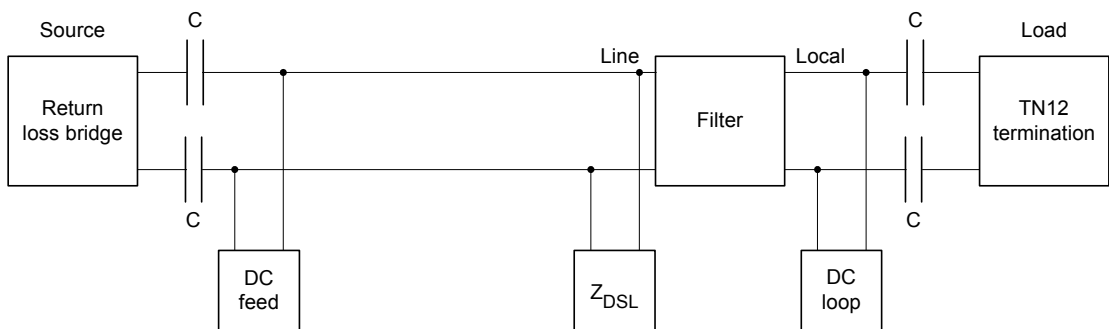

FIGURE 6
Test for PSTN transient effects



Distributed filter
Figure 7(a)



Centralised filter
Figure 7(b)

FIGURE 7
Return loss measurements

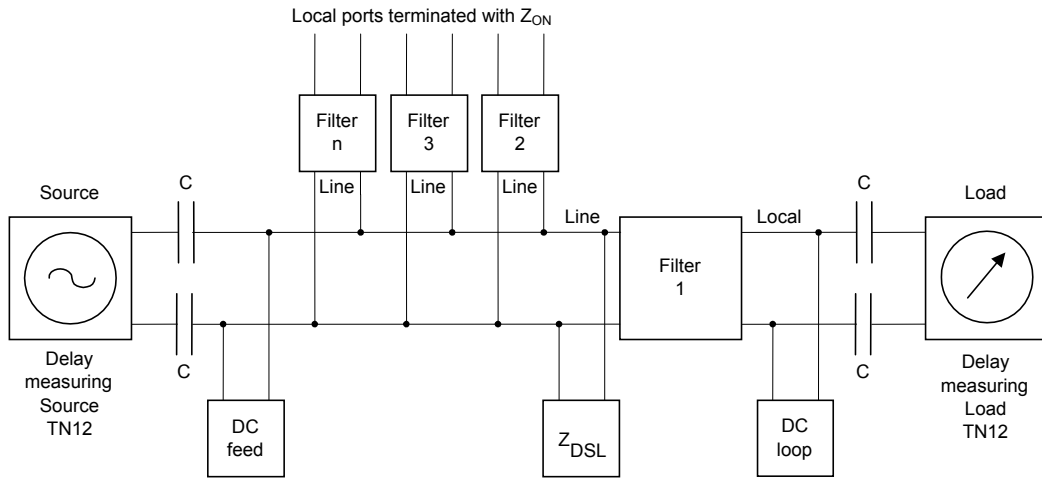

Distributed filter
Figure 8(a)

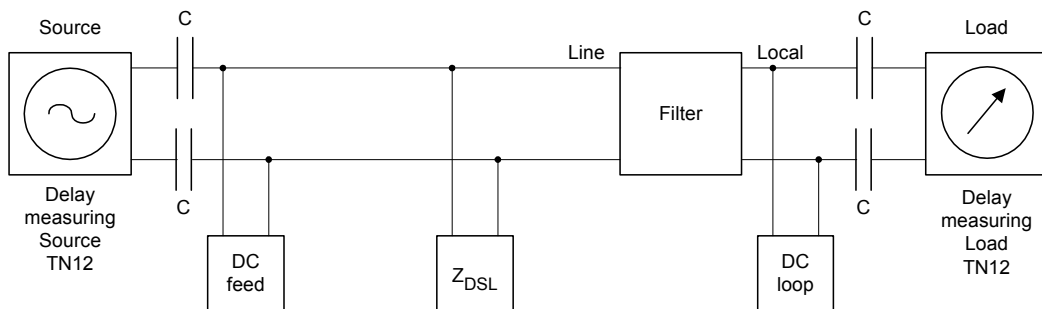

Centralised filter
Figure 8(b)

FIGURE 8
Group delay measurements

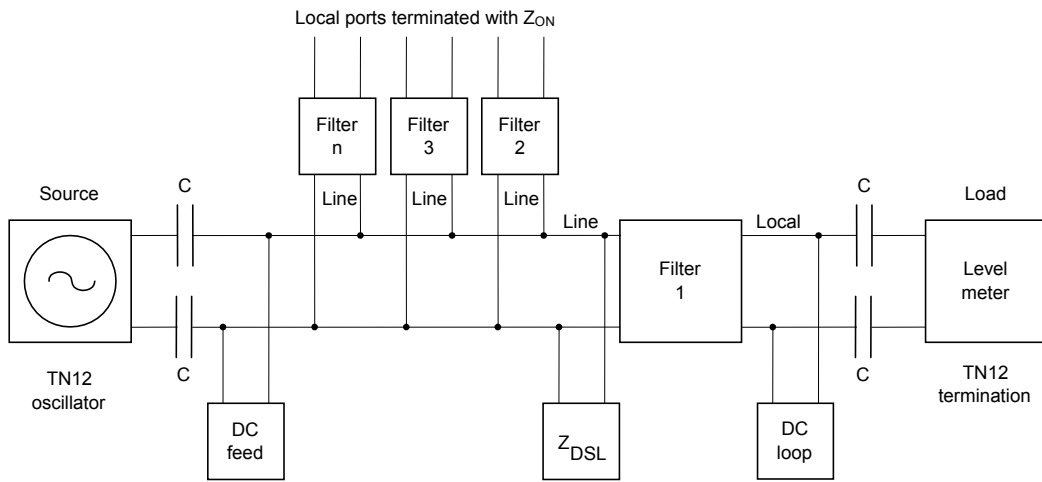

Distributed filter
Figure 9(a)

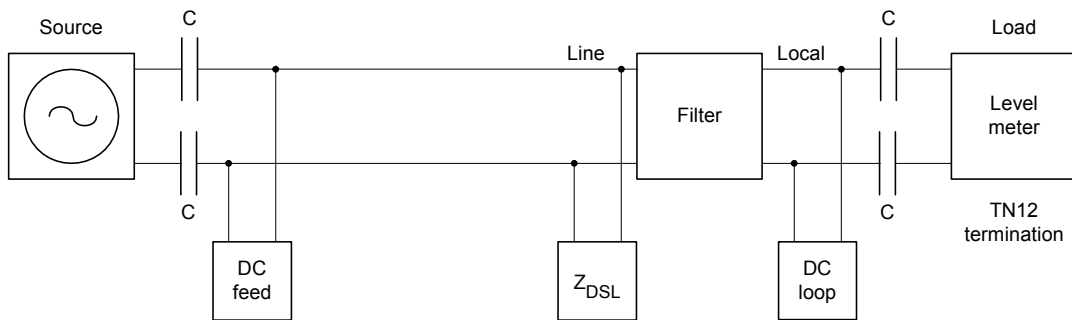

Centralised filter
Figure 9(b)

FIGURE 9

Voiceband filter loss (on-line) / distortion measurements

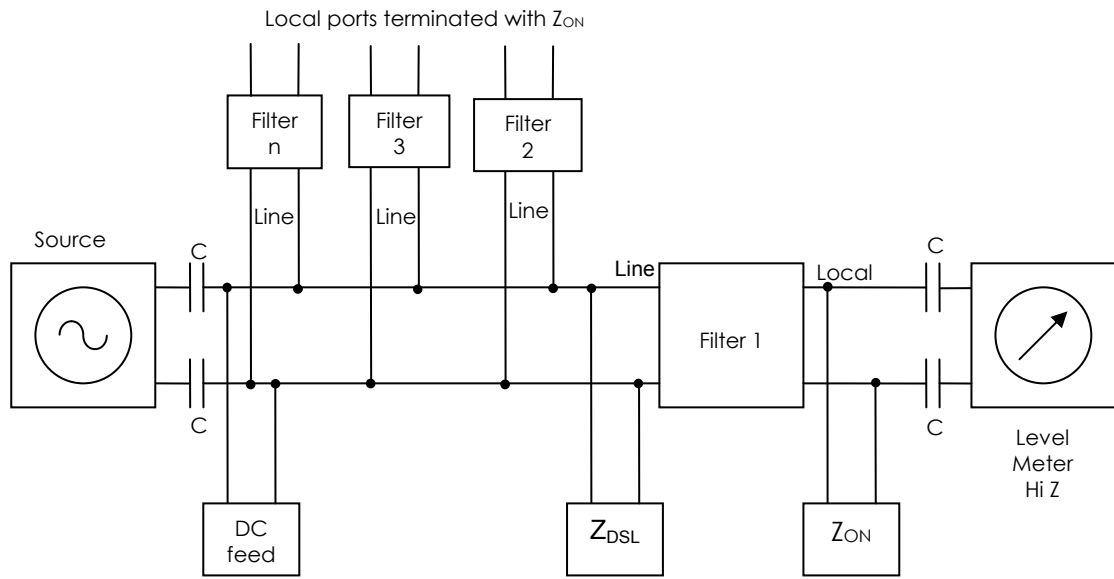

Distributed filter
Figure 10(a)

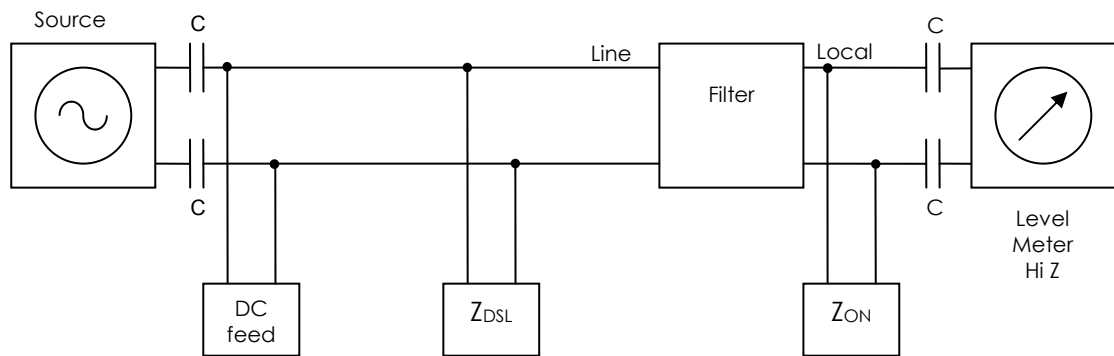

Centralised filter
Figure 10(b)

FIGURE 10
Voiceband filter loss (off-line) measurements

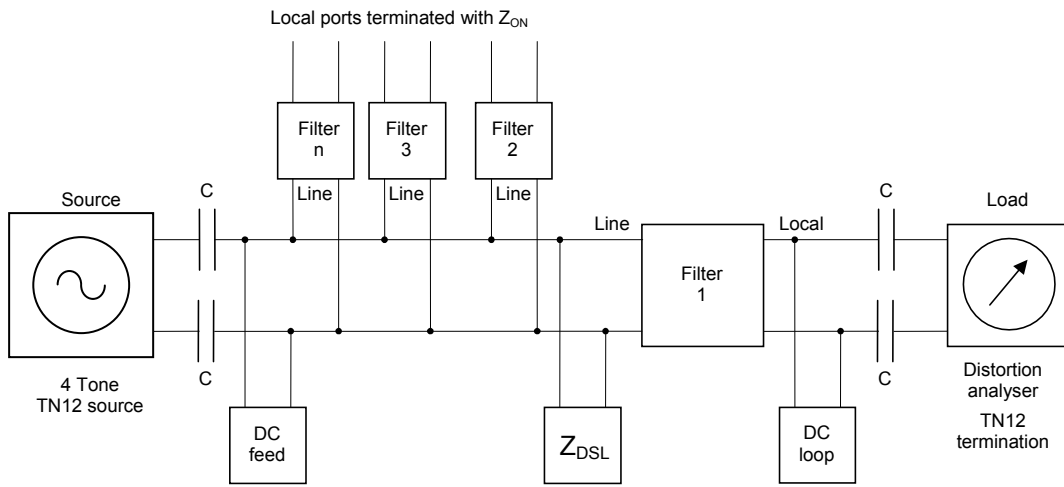

Distributed filter
Figure 11(a)

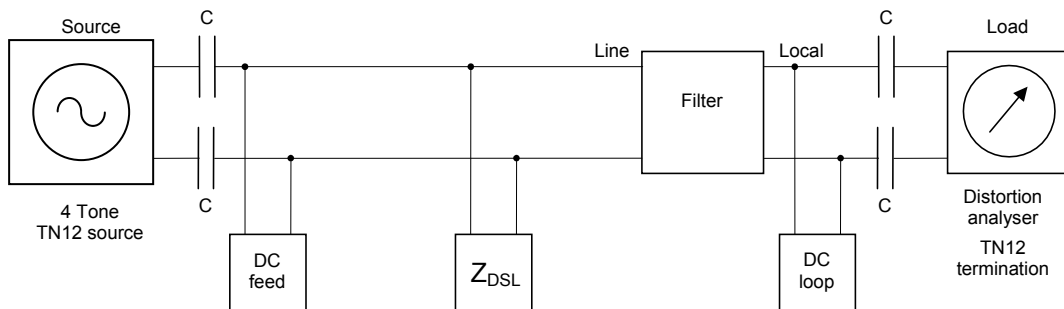

Centralised filter
Figure 11(b)

FIGURE 11
Intermodulation measurements

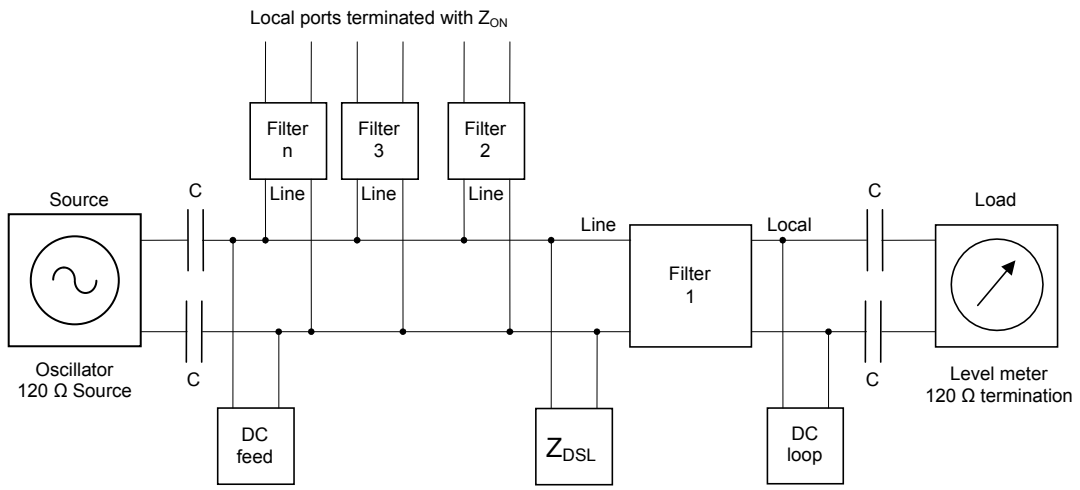

Distributed filter
Figure 12(a)

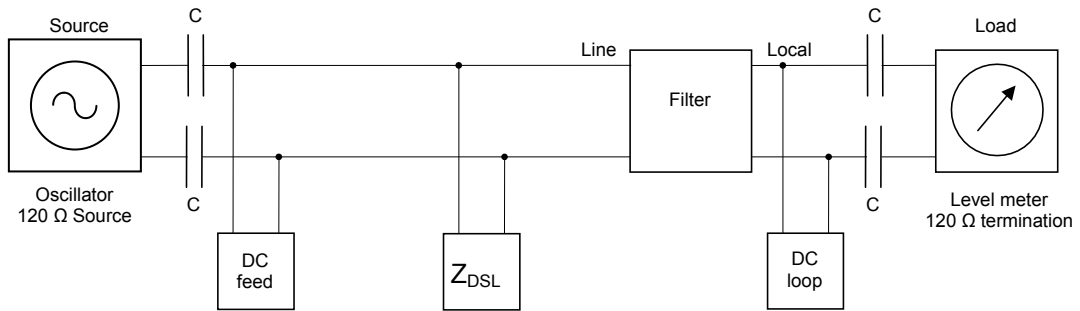

Centralised filter
Figure 12(b)

FIGURE 12
DSL band loss measurements

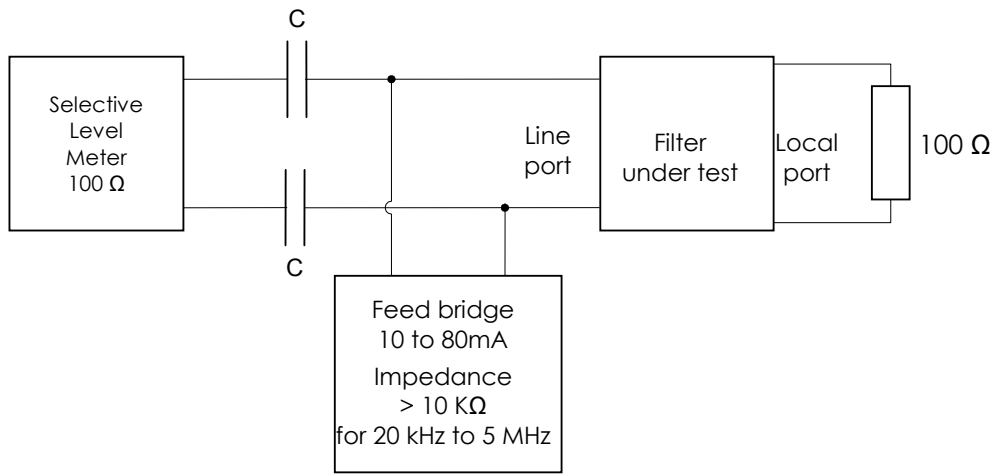

FIGURE 13
ADSL band noise measurements

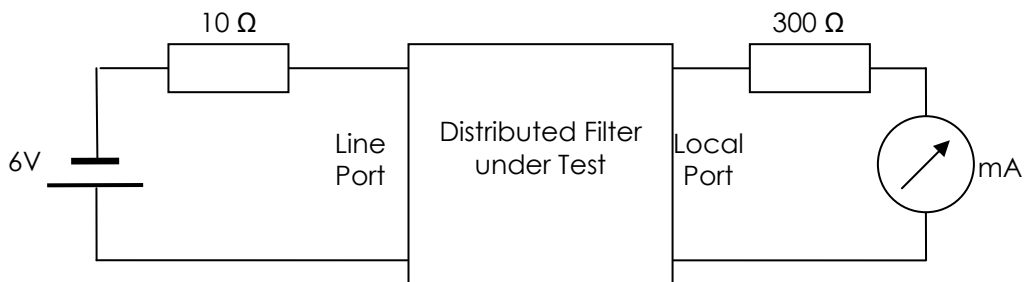
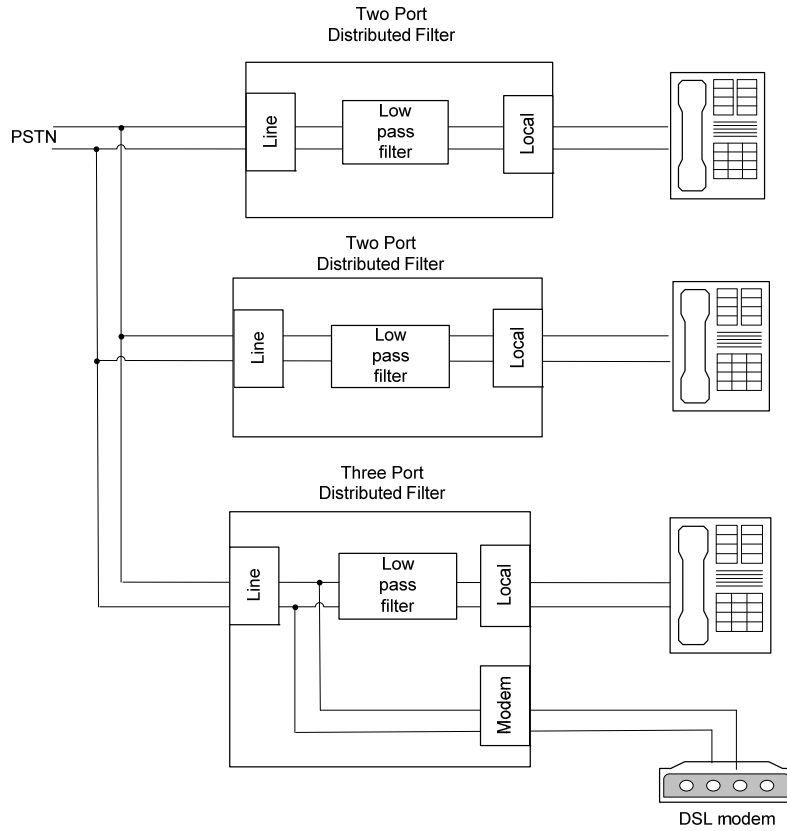
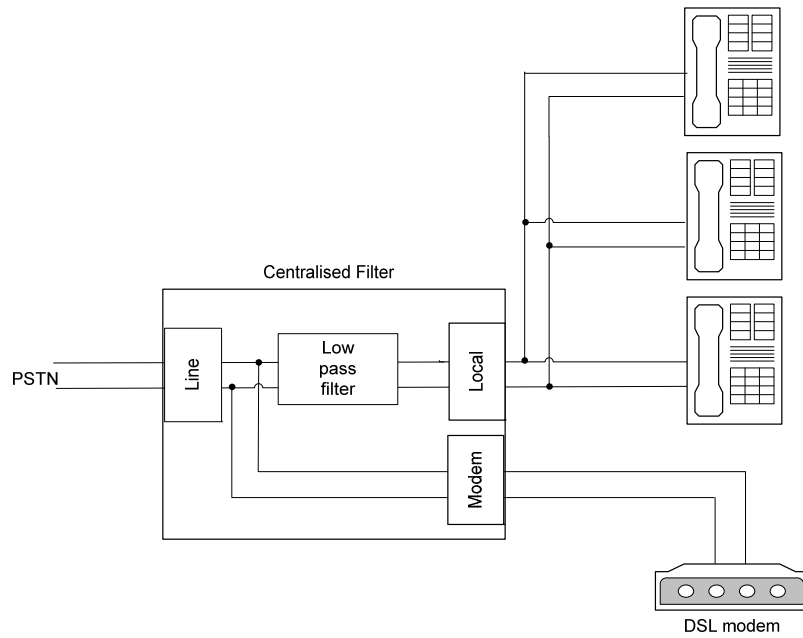

FIGURE 14
Test circuit for parallel handover



Distributed Filter Configuration
Figure 15(a)



Centralised Filter Configuration
Figure 15(b)

FIGURE 15
Filter use for isolation of DSL functions from PSTN CE

PARTICIPANTS

The Working Committee responsible for the revisions made to this Standard consisted of the following organisations:

Organisation	Membership
Advanced Circuit and Systems	Voting
Testing & Certification Australia	Voting
C10 Communications	Voting
Cisco Systems	Voting
Comtest Laboratories	Voting
Optus	Voting
Industry Expert	Voting
Telephone Equipment NSW	Voting
Telstra	Voting
Thomson Telecom Australia	Voting
Australian Communications and Media Authority	Non-voting
Communications Alliance	Non-voting

This Working Committee was chaired by Mike Johns of Communications Alliance Ltd who also provided project management support.

NOTES

Communications Alliance was formed in 2006 to provide a unified voice for the Australian communications industry and to lead it into the next generation of converging networks, technologies and services.

In pursuing its goals, Communications Alliance offers a forum for the industry to make coherent and constructive contributions to policy development and debate.

Communications Alliance seeks to facilitate open, effective and ethical competition between service providers while ensuring efficient, safe operation of networks, the provision of innovative services and the enhancement of consumer outcomes.

It is committed to the achievement of the policy objective of the *Telecommunications Act 1997* - the greatest practicable use of industry self-regulation without imposing undue financial and administrative burdens on industry.



**Published by:
COMMUNICATIONS
ALLIANCE LTD**

**Level 9
32 Walker Street
North Sydney
NSW 2060 Australia**

**Correspondence
PO Box 444
Milsons Point
NSW 1565**

**T 61 2 9959 9111
F 61 2 9954 6136
TTY 61 2 9923 1911
E info@commsalliance.com.au
www.commsalliance.com.au
ABN 56 078 026 507**

Care should be taken to ensure the material used is from the current version of the Standard or Industry Code and that it is updated whenever the Standard or Code is amended or revised. The number and date of the Standard or Code should therefore be clearly identified. If in doubt please contact Communications Alliance

ISBN: 1 74000 391 8