

AUSTRALIAN
COMMUNICATIONS
INDUSTRY FORUM



INDUSTRY GUIDELINE

Companion to AS/ACIF S009:2006 Installation
requirements for customer cabling (Wiring rules)

Comparison of the 2001 and 2006 editions

Industry Guideline – Companion to AS/ACIF S009:2006 Installation requirements for customer cabling (Wiring rules)

First published in 2006

Disclaimers

1. Notwithstanding anything contained in this Guideline:
 - (a) ACIF disclaims responsibility (including where ACIF or any of its officers, employees, agents or contractors has been negligent) for any direct or indirect loss, damage, claim, or liability any person may incur as a result of any:
 - (i) reliance on or compliance with this Guideline;
 - (ii) inaccuracy or inappropriateness of this Guideline; or
 - (iii) inconsistency of this Guideline with any law; and
 - (b) ACIF disclaims responsibility (including where ACIF or any of its officers, employees, agents or contractors has been negligent) for ensuring compliance by any person with this Guideline.
2. The above disclaimers will not apply to the extent they are inconsistent with any relevant legislation.

Copyright

© Australian Communications Industry Forum Limited 2006

This document is copyright and must not be used except as permitted below or under the Copyright Act 1968. You may reproduce and publish this document in whole or in part for your or your organisation's own personal or internal compliance, educational or non-commercial purposes. You must not alter or amend this document in any way. You must not reproduce or publish this document for commercial gain without the prior written consent of ACIF. Organisations wishing to reproduce or publish this document for commercial gain (i.e. for distribution to subscribers to an information service) may apply to subscribe to the ACIF Publications Subscription Service by contacting the ACIF Business Manager at acif@acif.org.au. If you publish any part of this document for any purpose, you must also publish this copyright notice as part of that publication.

INTRODUCTION

The AS/ACIF S009:2006, *Installation requirements for customer cabling (Wiring Rules)* Australian Standard was published on 12 April 2006 and is to replace AS/ACIF S009:2001 on 1 July 2006.

AS/ACIF S009 ('S009') is otherwise known as the ACMA (formerly ACA) Wiring Rules and is legally enforceable through the Cabling Provider Rules. The Wiring Rules are not legally binding on any person who is not a registered cabling provider, e.g. customers or building owners. However, it is a criminal offence under the *Telecommunications Act 1997* for a person to perform 'cabling work' on the customer's side of the network boundary without cabling provider registration. For more details, refer to the ACMA web site at <http://www.acma.gov.au/>.

Differences between AS/ACIF S009:2006 and the previous 2001 edition are described in this Guideline to assist training providers, cabling providers and any authors of documents that reference S009, in identifying the changes that have been made to the Wiring Rules.

If there are any differences in the information contained in this Guideline and the AS/ACIF S009:2006 Standard, the Standard remains the authoritative source.

Note: The AS/ACIF S008:2006 *Requirements for customer cabling products* Australian Standard, was also published to replace AS/ACIF S008:2001, and is complementary to AS/ACIF S009:2006.

Regulatory information

AS/ACIF S009:2006 remains a voluntary Standard and AS/ACIF S009:2001 remains the mandatory 'Wiring Rules' Standard until AS/ACIF S009:2006 comes into force as a mandatory Standard on 1 July, 2006.

In the *Regulatory notice* of the FOREWORD to AS/ACIF S009:2006, reference is made to 'subordinate regulatory instruments administered by (ACMA)'. An example of a subordinate regulatory instrument is the *Telecommunications Cabling Provider Rules 2000*, which is the legal instrument ACMA uses to put into effect the basic principles for regulation of cabling providers set out in the *Telecommunications Act 1997*.

Availability

AS/ACIF S009:2006 and this companion Guideline can be downloaded from http://www.acif.org.au/documents_and_lists/standards.

Acknowledgement

ACIF gratefully acknowledges the work of Terry Phillips (editor of AS/ACIF S009:2006) and Telstra for preparing this companion guideline and making it available to ACIF for the benefit of the telecommunications industry.

GENERAL CHANGES

Content

AS/ACIF S009:2001 was stripped down to the bare essentials compared to its predecessor (ACA TS 009-1997). However, AS/ACIF S009:2006 reverses this situation with the inclusion of a large amount of informative material to assist comprehension of the Standard and compliance with it.

Structure

S009 has been restructured into 20 sections. It also has one normative appendix and ten informative appendices.

These sections and appendices are:

1. Scope
 2. References
 3. Definitions and abbreviations
 4. General principles
 5. General requirements
 6. Hazardous conditions associated with HV power
 7. Hazardous areas and damp locations
 8. Cable supports and enclosures
 9. Separation of services — general
 10. Surge suppression
 11. Optical fibre and coaxial cable systems
 12. Distributors
 13. Main distribution frame (MDF)
 14. Network termination device (NTD)
 15. Telecommunications outlets
 16. Indoor cabling
 17. Outdoor cabling — general
 18. Underground cabling
 19. Aerial cabling
 20. Telecommunications earthing and power distribution
- Appendix A (normative) Restricted zones in damp locations
Appendix B (informative) Common cable colour codes
Appendix C (informative) Telecommunications outlets
Appendix D (informative) Recommended access clearances for MDFs and NTDs
Appendix E (informative) Direct current in the communications bonding conductor
Appendix F (informative) Current-limited power feeding in telecommunications networks
Appendix G (informative) LV telecommunications circuits
Appendix H (informative) Interference from HV power systems
Appendix I (informative) The IP Code
Appendix J (informative) The network boundary
Appendix K (informative) Cabling Provider Rules

Each subject within each section has been given a clause number and every clause number has a heading. Clauses may contain paragraphs, e.g. (a), (b), (c), etc., and subparagraphs, e.g. (i), (ii), (iii), etc.

These structural changes are intended to make it easier to find information.

Definitions/Terminology

The old term, '**MDF**', has been resurrected to replace the existing, unpopular expression, '**network boundary distributor**'. The term '**main distribution frame**' is still used in the legislation, so reverting back to this term may alleviate some confusion. Hopefully, there will be no more changes to this term in future editions of S009!

The **NTD Enclosure (NTDE)** concept has been abandoned and NTDE requirements deleted. NTDs remain but are generally outside the scope of S009 because they are normally provided by the carrier. NTDs are better explained in the new Standard and application guidelines are provided for MDFs, NTDs and the 'first socket'.

Definitions for **underground cabling** and **aerial cabling** have been included to clarify that they are external to a building. Cables installed under floors or suspended between any points within a building are not classified as underground or aerial cabling.

Voltage and service classifications have been redefined with the inclusion a new service classification, '**LV telecommunications circuit**', for hazardous telecommunications circuits, such as EWIS (Emergency Warning and Intercommunication System) cabling, which are subject to ACMA technical regulation. A new appendix has been included explaining this new service classification. New requirements have also been introduced in S009 to accommodate such services. New requirements have been added and existing requirements amended to accommodate other fire detection and fire alarm system cabling and building control system cabling, which are all subject to ACMA technical regulation.

Network boundary

A 13-page appendix has been included to provide definitive guidance on the location of the network boundary for various technologies and in various circumstances. Figure J.15 (reproduced at right) amends an earlier interpretation, contained in HB 243:2000, as to the precise location of the network boundary in a building MDF.

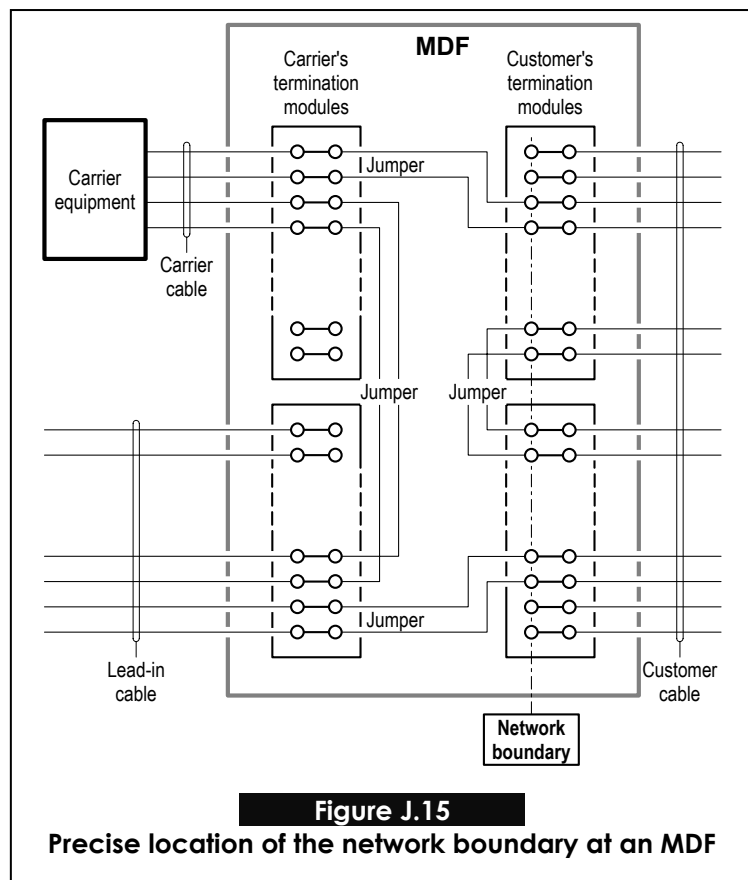

KEY CHANGES OR INCLUSIONS

The most significant changes or inclusions are described below. The less significant changes or inclusions are identified in the **TABULATION OF CHANGES** commencing from Page 9.

Use of conduit marked 'ELECTRICAL'

The use of conduit with visible and dangerously misleading markings for telecommunications cabling, such as grey conduit marked 'ELECTRICAL', is cited as an example of an unsafe practice. Clause 5.1 of AS/ACIF S009:2006 refers. Note that if such markings are not visible (e.g. painted over or embedded in concrete), they are acceptable — as long as the conduit is not a prohibited colour.

Attachment of cabling to another service cable, conduit or pipe

Attachment of cabling to another service (e.g. a power cable/conduit or water/waste pipe) is expressly prohibited. Clause 8.2.1 of AS/ACIF S009:2006 refers.

Cabling in suspended ('false') ceilings

Cabling in a suspended ('false') ceiling must be separately supported and not be laid on the ceiling tiles or tied to the ceiling hanger rods. Clause 8.2.2 of AS/ACIF S009:2006 refers.

Proper use

Cabling products must only be used for their intended purpose (e.g. cord or cordage should not be used for fixed or concealed cabling unless this application is supported by the manufacturer of the product). Clause 5.5 of AS/ACIF S009:2006 refers.

LV telecommunications circuits

LV telecommunications circuits are classed as hazardous services and must be separated from other telecommunications services in the same way as power cables. In addition, they must be separated from power cables in the same way as other telecommunications services. However, they may be sub-ducted in telecommunications conduits with other telecommunications cables under certain conditions. Any cable carrying an LV telecommunications circuit must be clearly identifiable at any access point. The required identification may include appropriate sheath markings or labelling of the cable by the installer. Clauses 5.6, 9.3 and 8.3.3.2 of AS/ACIF S009:2006 refer.

Cable with red sheath

Cable with red sheath should only be used for cabling associated with a fire detection and fire alarm system. Clause 5.7 of AS/ACIF S009:2006 refers.

Cabling above fire detection and fire alarm system cables

Cables and cable support systems should not be installed above fire detection and fire alarm system cables (so that operation of the fire detection and fire alarm system will not be prevented by the collapse of other cables or cable support systems, e.g. due to heat or fire). Clause 8.7 of AS/ACIF S009:2006 refers.

Earth potential rise (EPR) and low frequency induction (LFI)

Because EPR and LFI are subjects that are not well understood, an 11-page appendix has been included explaining what EPR and LFI are and how their effects can be avoided. Other types of HV interference are also discussed. In addition, the EPR requirements in the body of the Standard have been made less onerous.

Damp area restricted zones

Instead of a cross-reference to AS/NZS 3000 for defining damp area restricted zone boundaries, the boundaries are now defined in S009. Appendix A describes the restricted zones for bath and shower locations using both text and drawings (see Figure A.2 at right). These zones differ slightly to the zones described in AS/NZS 3000 because the AS/NZS 3000 requirements are too complex for telecommunications purposes.

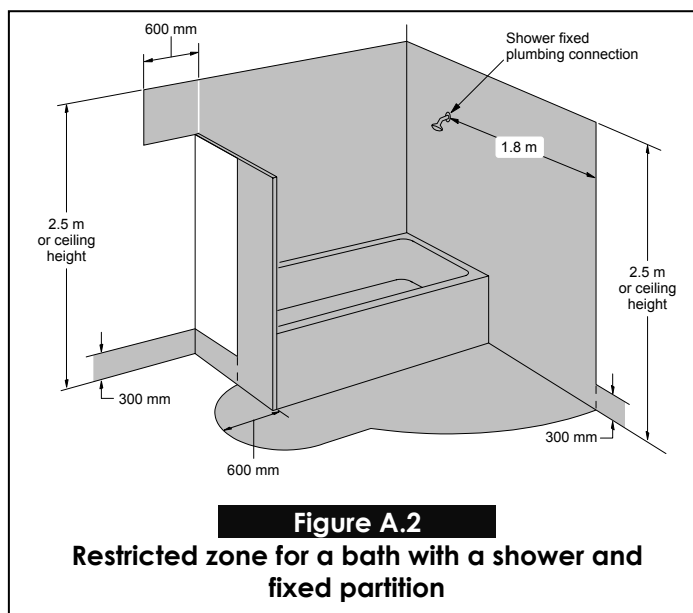

Separation from a cable, conduit or pipe of another service

Cables must be separated from other services so as not to impede access to, or repair of, the other service. A minimum separation of 50 mm is recommended for parallel runs with other services. Clause 9.2.1 of AS/ACIF S009:2006 refers. The additional requirement for a minimum of 100 mm separation from non-electrical hazardous services (e.g. gas, oil, steam or compressed air pipes) remains (Clause 9.2.2 of AS/ACIF S009:2006 refers).

ELV circuit terminations

ELV circuit terminations must be separated from other telecommunications circuit terminations by 150 mm or a fixed barrier. The reason is explained in a note. This is consistent with AS/NZS 60950.1 and actually reinstates a requirement that existed in earlier editions of TS 009. Clause 9.3.2 of AS/ACIF S009:2006 refers.

Assessing the need for surge suppression

It is now only necessary to assess the need for surge suppression at a building that does not contain the network boundary where twisted pair cable (as distinct from coaxial or optical fibre cable) runs to that building. Clause 10.1 of AS/ACIF S009:2006 refers.

Surge suppression earthing

The requirements for earthing of surge suppression devices have been more clearly separated into end-user protection and equipment protection categories for consistency with the reference standards. Notes are provided for guidance. Clause 20.20 of AS/ACIF S009:2006 refers.

Connection of cabling to a carrier's changeover (C/O) switch

A manual changeover switch has been removed as an allowable connection point for customer cabling. It is up to the relevant carrier as to whether or not to allow connection at this point. Telstra allows it in its 'A2A' ('Authorisation To Alter') specification (available at www.telstrasmartcommunity.com). Publication of a document by a carrier authorising cabling providers to alter certain carrier facilities (such as Telstra's 'A2A' specification) is now explicitly supported by the Note to Clause 5.13 of AS/ACIF S009:2006.

8P modular sockets in premises frequented by small children

While 8P (so-called RJ45) modular sockets pass the test probe requirements of AS/NZS 60950.1 (which is all that telecommunications sockets are required to do), they fail the test finger requirements AS/NZS 60950.1 (which means a small human finger can touch the contacts inside). Therefore, where 8P modular sockets are located in premises frequented by small children (e.g. a kindergarten or child care centre), they should be provided with mechanical protection (e.g. a shutter) that prevents finger access to the contact springs, or be installed out of reach. Clause 15.2 of AS/ACIF S009:2006 refers.

Cable flammability

Cable flammability has always been a controversial issue. Notes have been included in Clause 16.1 of AS/ACIF S009:2006 to provide guidance in application of this requirement.

Outdoor cable/equipment exposure to sunlight

Outdoor cable or equipment exposed to sunlight must be made of UV resistant material or mechanically protected from UV exposure (which may include painting in some circumstances). Underground cable, other than coaxial cable, special application cable or a blown fibre tube system, must be UV resistant as well as water resistant. Additional guidance is provided for underground use of cable with appropriate properties. Clauses 17.4 and 18.4 of AS/ACIF S009:2006 refer.

Pits or access holes traversed by heavy vehicles

A pit or access hole that may be traversed by heavy vehicles must either be protected by suitable barriers to prevent entry of vehicles to the area or be engineered to safely carry the load. Clause 18.1.3 of AS/ACIF S009:2006 refers.

Outdoor conduit

Outdoor conduit, other than underground conduit (see below), may now be any type (as long as it is not a prohibited colour and does not have visible misleading markings that may create a safety hazard). This change was effected by limiting the requirement to use compliant conduit to underground cabling instead of outdoor cabling.

Underground conduit

Flexible or corrugated conduit may now be used for underground cabling, although rigid conduit is recommended for drawing in cables. This follows from an amendment to the conduit requirements in S008 that allows the conduit to be flexible or corrugated type. Underground, non-metallic conduit must be coloured white or have a white stripe and be marked 'COMMUNICATIONS'. Recommendations for use of conduit, marking tape or marking the cable route are also included. Clause 18.3 of AS/ACIF S009:2006 refers.

Exclusion zones

Cabling providers are required to comply with relevant State or Territory regulations for working near underground utility services (e.g. power, gas, water or sanitation) or aerial power lines. Clauses 18.11 and 19.8 of AS/ACIF S009:2006 refer.

Aerial cabling — general

The aerial cabling requirements have been reviewed and expanded to address some deficiencies and anomalies.

Aerial cabling between buildings

Various amendments have been made throughout the Standard to specifically allow indoor type cable to be run as aerial cable between buildings as long as such cable is enclosed in conduit for protection from UV exposure. The conduit may be tied to the same catenary wire as LV power cable (the conduit provides the required separation). However, the conduit must not be tied to the power cable (or power conduit) itself (see 'Attachment of cabling to another service cable, conduit or pipe' on page 4). Refer to AS/ACIF S009:2006, Clauses 8.2.1, 8.5 (d), 19.3.1 and 19.5.7.2 Note (a).

Aerial cable crossings and shared poles

The requirements for aerial crossings and shared poles have been consolidated and harmonised. The essential requirements of SAA HB 87 (Telstra/ESAA 'Joint Use Code') and SAA HB 103 (Telstra/ESAA 'Crossings Code') have been included in S009 and cross-references to HB 87 and HB 103 have been removed. An additional table (Table 3) has been added. Clause 19.5 of AS/ACIF S009:2006 refers.

Telecommunications earthing and power distribution

Telecommunications power distribution requirements have been added to the earthing section. Additional explanation and guidance is provided about the various earthing systems. Section 20 of AS/ACIF S009:2006 refers.

Earthing or bonding connections in EPR hazard zones

There is a new requirement that prohibits an earthing/bonding connection being made to any equipment, cabling, earth electrode or any earthed object that is located within an EPR hazard zone. A note explains why. Clause 20.5 of AS/ACIF S009:2006 refers.

Functional earthing of customer equipment

Detailed requirements are provided for functional earthing of customer equipment manufactured to current and previous standards in which the terminology used and earthing requirements specified may differ. Clause 20.6 of AS/ACIF S009:2006 refers.

Protective earth

The expression 'protective earth' has been reintroduced because it is the term used in the relevant customer equipment standards. Means of providing a protective earth are described in more detail, including cases where there is no electrical earthing system at the building. Clause 20.7 of AS/ACIF S009:2006 refers.

Earthing and bonding bars and terminals

Screw terminations are now expressly required for connection of earthing and bonding conductors at earthing or bonding bars/terminals. This was a requirement, by default, of S009:2001 but there was some uncertainty about it. S009:2001 also allowed the use of 'earthing modules' for connection of individual signalling conductors or drain wires, but there was some uncertainty about this as well. S009:2006 clarifies this situation. Clause 20.9.2 of AS/ACIF S009:2006 refers.

There is a new requirement for any earthing/bonding bar or terminal to be enclosed or located to prevent unintentional contact by any person who is not doing cabling work. Clause 20.9.3 of AS/ACIF S009:2006 refers.

Earthing and bonding conductor joints and couplings

The use of insulation displacement connectors has been expressly prohibited for jointing or coupling of earthing or bonding conductors. Clause 20.10.1.6 of AS/ACIF S009:2006 refers.

Resistance of the equipotential bonding conductor

The resistance of the equipotential bonding conductor must not exceed 0.5 ohm. This is included for consistency with AS/NZS 3000. Do not confuse this with the resistance of CES or TRC conductors whose resistance is measured differently. Clause 20.11.2.4 of AS/ACIF S009:2006 refers.

'Nominated distributor' renamed 'designated distributor' (TRC system)

The name of the distributor from which the TRC emanates has been changed to 'designated distributor' from 'nominated distributor'. Such a distributor may or may not be an MDF. Clause 20.13 of AS/ACIF S009:2006 refers.

Telecommunications functional earth electrode (TFEE) requirements

The requirements for selection and installation of the TFEE are now explicitly stated instead of a cross-reference to AS/NZS 3000. In addition, where the building does not have an electrical earth electrode, the TFEE must be connected via a differential earth clamp (a new Figure 5 shows the arrangement) for compatibility with AS/NZS 3000. Clause 20.13.8 of AS/ACIF S009:2006 refers.

DC earth return circuits

The requirements for DC earth return circuits have been expanded to include more detailed earth electrode and earthing conductor requirements. Clause 20.16 of AS/ACIF S009:2006 refers.

Earthing diagrams

Figures 1-4 have been updated. A total maximum earthing/bonding conductor length of 1.5 m or less is recommended (but not mandatory) for surge protection purposes.

Two additional figures (Figures 5 and 6) have been added for connection of a TFEE at an outbuilding and connection of an outdoor cable shield.

TABULATION OF CHANGES

Translation of AS/ACIF S009:2001 to AS/ACIF S009:2006 is presented in the following pages in tabular format. This will help you determine whether a current requirement has been carried into the new Standard and what changes, if any, have been made. It will also help you identify clause number changes for any documents that refer to specific clauses in AS/ACIF S009:2001. The table can also be used in reverse, i.e. to identify the corresponding clause, table or figure in AS/ACIF S009:2001 for a particular clause, table or figure in AS/ACIF S009:2006 — or whether a clause in AS/ACIF S009:2006 is a new requirement altogether.

The first column contains the old AS/ACIF S009:2001 clauses, tables and figures. The second column contains the corresponding clauses, tables and figures in the new AS/ACIF S009:2006 Standard.

Clause numbers in **bold** typeface are in numerical order for the relevant column, whereas clause numbers in normal typeface are out of numerical order and are duplicate entries that are included to enable the corresponding clause in either the old Standard (S009:2001) or the new Standard (S009:2006) to be easily identified.

A reference to 'the Act' is a reference to the *Telecommunications Act 1997*.

Old Clause S009:2001	New Clause S009:2006	Subject	Comments
Foreword, General	FOREWORD, General, 1.3	Statement about preparation of the Standard, Limitations	Minor editorial changes only
—	FOREWORD, Introduction	List of changes made to the Standard	
Foreword, Standards Revision	FOREWORD, Standards Revision	ACIF notice about currency of the Standard and submissions for changes to the Standard	Minor editorial changes only
Foreword, Regulatory notice	FOREWORD, Regulatory notice	ACA/ACMA notice about the regulatory status of the Standard	Minor editorial changes only
1	—	INTERPRETATION	Specific interpretative statements — now made elsewhere in S009:2006
1.1	4.2	Categories of requirements	Mandatory requirements are 'normative' (indicated by ' shall ' and ' shall not ') and all other requirements are 'informative'
1.2	—	Compliance statements	Deleted – not relevant to S009
1.3	3	DEFINITIONS AND ABBREVIATIONS, conflict with definitions in the Act	This statement is now at the start of section 3 of S009:2006
1.4	—	Notes ('... 'Note' is for guidance...')	Unnecessary – covered by Clause 4.2 of S009:2006

Old Clause S009:2001	New Clause S009:2006	Subject	Comments
1.5 1.5.1 1.5.2 1.5.3 1.5.4 1.5.5 1.5.6	2 — 2.1 — — — 2.1	REFERENCES	All references are dated and only the edition of the reference identified applies
1.6	4.3	Units and symbols	No change
2	1	SCOPE	
2.1	1.1	Application	Clarification has been included that the Standard: <ul style="list-style-type: none"> • applies to any cord or cordage that is connected as fixed or concealed cabling • does not apply to any power cabling used to carry telecommunications, e.g. broadband over power lines • applies to cabling work that was previously exempt or not specifically addressed
—	1.2	Date of effect	S009:2006 does not come into effect until 1 July, 2006.
Foreword, General	1.3	Limitations	Editorial changes only
2.2	1.4	Basic aims	Translates the 'health and safety' and 'network integrity' requirements of the Act to cabling requirements
2.3	1.5	Topics	Editorial changes only
2.4	2.1	The Standard should be read in conjunction with associated standards	Normative references are now deemed to be 'indispensable'
3 — —	2 2.1 2.2	REFERENCES Normative references Informative references	Normative and informative references are listed separately
4	3	DEFINITIONS AND ABBREVIATIONS	Abbreviations are now listed after the definitions instead of vice versa
4.1	3.2	Abbreviations	Deleted: CE, e.g., etc., i.e., MEN, NTDE, TLN, UPVC Amended: ACA to ACMA, CSS to CAE New: EWIS, IEC, ISDN, OH&S, ISO, PABX, SWER, ULLS, UV
4.2	3.1	Definitions	

Old Clause S009:2001	New Clause S009:2006	Subject	Comments
—	3.1.1	AC mains supply	New — replaces use of the term 'power mains' that was used in S009:2001
—	3.1.2	aerial cabling	New — clarifies that aerial cabling is external to a building
4.2.1	3.1.3	building	No change
—	3.1.4	Building Code	New — referred to in Clauses 4.4.2, 16.1 and 16.2 of S009:2006
4.2.2	3.1.5	building entry point	No change
—	3.1.6	cable	New — included to make a distinction between 'cable' and 'cabling'
—	3.1.7	cabling	New — included to make a distinction between 'cable' and 'cabling'
4.2.3	3.1.8	cabling product	Editorial changes only
4.2.4	3.1.9	cabling provider	Editorial changes only
4.2.5	3.1.10	Cabling Provider Rules	No change
4.2.6	3.1.11	cabling work	Note added for clarification regarding fixed or concealed cord or cordage
4.2.7	3.1.12	carriage service	Editorial changes only
4.2.8	3.1.13	carriage service provider	Editorial changes only
4.2.9	3.1.14	carrier	Editorial changes only
4.2.10	3.1.15	catenary support system	No change
4.2.11	3.1.16	Certified Components List (CCL)	Updated (ACA changed to ACMA)
4.2.12	3.1.17	Communications Earth System (CES)	Editorial changes only
4.2.13	3.1.18	Communications Earth Terminal (CET)	Note added about the purpose of the CET
4.2.14	3.1.19	compliant	Editorial changes only
—	3.1.20	conductive pole or structure	New — used in section 19 of S009:2006
4.2.15	3.1.21	conduit	Note amended
4.2.16	3.1.22	connected	The actual definition from the Act is now used
—	3.1.23	cord	New — significant to S009:2006 application (Clauses 1.1, 3.1.11) and for certain requirements (Clauses 16.3.1 Note 3, 16.7.1)
—	3.1.24	cordage	New — significant to S009:2006 application (Clauses 1.1, 3.1.11)

Old Clause S009:2001	New Clause S009:2006	Subject	Comments
4.2.17	3.1.25	cross-connection	No change
4.2.20	3.1.26	customer access equipment (CAE)	Was Customer Switching System (CSS) (aligned with AS/ACIF S003)
4.2.18	3.1.27	customer cabling	Editorial changes only
4.2.19	3.1.28	customer equipment	Editorial changes only
—	3.1.29	damp location	New — assists interpretation of Clause 7.2
4.2.48	3.1.30	designated distributor	Was 'nominated distributor'
4.2.20	3.1.26	customer access equipment (CAE)	Was Customer Switching System (CSS) (aligned with AS/ACIF S003)
4.2.21	3.1.31	differential earth clamp	No change
4.2.22	3.1.32	distributor	Editorial changes only
—	3.1.33	duct	New — included to make a distinction between 'conduit' and 'trunking'
4.2.23	3.1.34	earth potential rise (EPR)	Note amended slightly, Note 2 added
4.2.24	3.1.35	electrically conductive elements	Carbon fibre strengthener added
4.2.25	3.1.36	enclosure	ELV added
4.2.26	3.1.75	terminal equipment	Was 'end-user equipment', also redefined
4.2.27	3.1.37	EPR hazard zone	No change
—	3.1.38	equipotential bonding	New — corrects omission from S009:2001
4.2.28	3.1.39	extra-low voltage (ELV)	Service classification added
	3.1.78.1	ELV	Voltage definition
	3.1.79.4	ELV circuit	Service definition
—	3.1.40	facility	New — included because 'facility' has a special meaning in the Act
4.2.29	3.1.41	first socket	Editorial changes, notes added
—	3.1.42	functional earth	New — included for consistency with AS/NZS 60950.1
—	3.1.43	hazardous area (explosive atmosphere)	New — corrects omission from S009:2001
4.2.30	3.1.44, 3.1.79.11	hazardous service	Editorial changes, hazardous telecommunications cable example added
4.2.31	3.1.45, 3.1.78.5	hazardous voltage	Editorial changes only

Old Clause S009:2001	New Clause S009:2006	Subject	Comments
4.2.32	3.1.46 3.1.78.4 3.1.79.9 3.1.79.10	high voltage (HV) HV HV power HV circuit	Service classifications added Voltage definition Service definition Service definition
4.2.33	3.1.47	HV site	Shortened, more info is provided in Appendix H
4.2.34	3.1.48	indoor cabling	Editorial changes only
4.2.35	3.1.49	isolation device	No change
4.2.36	3.1.50	jumper	Expanded
4.2.37	3.1.51	lead-in cabling	'Property entry point' replaced by 'carrier's distribution point'
4.2.38	3.1.52, 3.1.79.6	limited current circuit	Editorial changes, notes added
4.2.39	3.1.53	line	Editorial changes only
4.2.40	3.1.54	low frequency induction (LFI)	Expanded, more info is provided in Appendix H
4.2.41	3.1.55 3.1.78.3 3.1.79.7 3.1.79.8	low voltage (LV) LV LV telecommunications LV power	Service classifications added Voltage definition Service definition Service definition
4.2.42	3.1.56	main distribution frame (MDF)	Replaces 'network boundary distributor' definition
4.2.43	—	multiple earthed neutral (MEN) system	Deleted (term not used in S009:2006)
4.2.44	3.1.57, J.3	network boundary	Amended, Appendix J explains the network boundary in detail
4.2.45	3.1.56	main distribution frame (MDF)	Replaces 'network boundary distributor' definition
4.2.46	3.1.58	network termination device (NTD)	Amended, Appendix J provides more info
4.2.47	—	network termination device enclosure (NTDE)	Deleted (concept abandoned)
4.2.48	3.1.30	designated distributor	Formerly called 'nominated distributor' (actual meaning unchanged)
4.2.49	3.1.59	outdoor cabling	Editorial changes only
4.2.50	3.1.60	patch cord	Editorial changes only
4.2.51	3.1.61	power feeding	Editorial changes only
4.2.52	3.1.62	premises	No change
4.2.53	—	property entry point	Deleted — term not used in S009:2006

Old Clause S009:2001	New Clause S009:2006	Subject	Comments
—	3.1.63	protective earth	New — included for consistency with AS/NZS 60950.1
4.2.54	3.1.64	protective earthing conductor	Note added
4.2.55	3.1.65	readily accessible	No change
—	3.1.66	restricted access location	New — used in Clauses 9.1.2.2, 9.1.2.3, 20.2.3, 20.15 of S009:2006
4.2.56	3.1.67, 3.1.79.3	safety extra-low voltage (SELV) circuit	Expanded
—	3.1.68	sub-duct	New — used in Clauses 8.3, 9.3, 18.3 of S009:2006
4.2.57	3.1.69	telecommunications functional earth electrode (TFEE)	No change
4.2.58	3.1.70	Telecommunications Labelling Notice	Editorial changes only
4.2.59	3.1.71	telecommunications network	Editorial changes only
4.2.60	3.1.72	telecommunications network voltage (TNV)	Divided into voltage definition and service definition
	3.1.78.2	TNV	Voltage definition
	3.1.79.5	TNV circuit	Service definition
4.2.61	3.1.73	telecommunications outlet (TO)	Editorial changes, notes added
4.2.62	3.1.74	Telecommunications Reference Conductor (TRC)	No change
4.2.26	3.1.75	Terminal equipment	Was 'end-user equipment', also redefined
4.2.63	3.1.76	trunking	Note added
—	3.1.77	underground cabling	New — clarifies that underground cabling is external to a building
—	3.1.78	voltage classifications	New — voltage classifications have been grouped together for ready comparison
4.2.28	3.1.78.1	extra-low voltage (ELV)	Editorial changes, note added — see also 3.1.79.4 'ELV circuit'
4.2.60	3.1.78.2	telecommunications network voltage (TNV)	Redefined in respect of voltages only — see also Clause 3.1.79.5 'TNV circuit'
4.2.41	3.1.78.3	low voltage (LV)	Editorial changes only — see also 'LV telecommunications circuit' (3.1.79.7) and 'LV power' (3.1.79.8)
4.2.32	3.1.78.4	high voltage (HV)	Editorial changes only — see also 'HV power' (3.1.79.9) and 'HV circuit' (3.1.79.10)

Old Clause S009:2001	New Clause S009:2006	Subject	Comments
4.2.31	3.1.78.5	hazardous voltage	Editorial changes only — see also Clause 3.1.79.11 'Hazardous service'
—	3.1.79	service classifications	New — defines 'services' as distinct from 'voltages'
—	3.1.79.1	primary circuit	New — ancillary to service definitions
—	3.1.79.2	secondary circuit	New — ancillary to service definitions
4.2.56	3.1.79.3	SELV circuit	Definition expanded, notes added
—	3.1.79.4	ELV circuit	New
4.2.60	3.1.79.5	TNV circuit	Complements TNV definition (3.1.78.2)
4.2.38	3.1.79.6	limited current circuit	Notes added to quantify limits
—	3.1.79.7	LV telecommunications circuit	New — included to cover some EWIS and PA system cabling, which may operate at hazardous voltages
—	3.1.79.8	LV power	New — included to make the distinction from an 'LV telecommunications circuit'
—	3.1.79.9	HV power	New — included to make the distinction from, say, lightning surge voltages and secondary HV circuits
—	3.1.79.10	HV circuit	New — added to embrace all HV circuits, including HV power
4.2.30	3.1.79.11	hazardous service	Editorial changes, note expanded
4.1	3.2	Abbreviations	Deleted: CE, e.g., etc., i.e., MEN, NTDE, TLN, UPVC Amended: ACA to ACMA, CSS to CAE New: EWIS, IEC, ISDN, OH&S, ISO, PABX, SWER, ULLS, UV
—	4	GENERAL PRINCIPLES	New heading
—	4.1	Objective	Sets the basic objective of the Standard, which reflects section 376 of the Act
1.1	4.2	Categories of requirements	Normative versus informative
1.6	4.3	Units and symbols	No change
—	4.4	Health and safety	Provides basic guidance to cabling providers

Old Clause S009:2001	New Clause S009:2006	Subject	Comments
—	4.4.1	Safety of the installation	States the basic aims for any cabling work performed
5.1.1.1	4.4.2	Occupational health and safety (OH&S) requirements	Alerts the cabling provider to general OH&S requirements
—	4.5	Network integrity	Lists relevant standards for certain types of cabling work
—	4.6	Cabling provider competency standards	States the recommended cabling provider competency standard categories
5	—	Requirements	Redundant heading
5.1	5	GENERAL REQUIREMENTS	New heading
5.1.1	—	Installation standards and conditions	Redundant heading
5.1.1.1	4.4.2	Occupational health and safety (OH&S) requirements	Alerts the cabling provider to general OH&S requirements
5.1.1.2	5.1	Safe and sound practice	Use of conduit marked 'ELECTRICAL' for customer cabling is cited as an example of an unsafe practice
5.1.1.2 Note	8.2.1	Attachment to other services	Attachment of customer cabling to other service cables and pipes now prohibited by Clause 8.2.1 of S009:2006
5.1.1.3	5.2	Manufacturer's instructions	No change
5.1.1.4	5.3	Compliance labelling	No change but a note has been added about earthing and telecommunications power components
5.1.1.5	5.4	Protection against damage	No change
—	5.5	Proper use	New requirement for cabling products to be used for their intended purpose
—	5.6	Cables used for LV telecommunications circuits	New requirement for such cables to be clearly identifiable at access points
—	5.7	Cable with red sheath	New recommendation in relation to fire detection and fire alarm system cabling
5.1.2	5.8	Cable joints	
5.1.2.1	5.8.1	Jointing method	Clarified for each cable type
5.1.2.2	5.8.2	Physical protection of the joint	No change
—	5.9	Cable terminations	New heading
5.1.11.1	5.9.1	Access to cable terminations	Expanded to cover all voltage/service classifications, notes added

Old Clause S009:2001	New Clause S009:2006	Subject	Comments
—	5.9.2	Separation from other services	This is merely a cross-reference to section 9 of S009:2006
5.1.3 5.1.3.1	4.1	Safety and integrity of telecommunications networks and facilities	This was too vague to enforce and is replaced by a more explicit, informative statement about the basic objective
5.1.3.2	5.10	Hazardous voltages	No change in practical terms
Note 1	4.5	Network integrity	No change in practical terms
Note 2	—	Examples on non-hazardous services	Note 1 was considered misleading and was deleted
	4.1 Note	Carrier's right to disconnect	No change
5.1.3.3	5.11	Interference to other circuits	Amended to include any circuit that is not connected to a telecommunications network
5.1.6	5.12	Alterations and additions	No change
5.3.1.1	5.13	Tampering or interference with a carrier facility	Note added to accommodate the principle of Telstra's 'A2A'
5.3.1.2	5.14	Defective customer cabling or customer equipment not to be reconnected	Reference to disconnection at the network boundary deleted (the cabling or equipment may be disconnected anywhere)
—	6	HAZARDOUS CONDITIONS ASSOCIATED WITH HV POWER	New heading
5.1.4	6.1	Earth potential rise (EPR)	
5.1.4.1	6.1.1	General	Telecommunications electrodes added, optical fibre joints excluded, Note 2 added
5.1.4.2	6.1.2	HV sites of particular concern	Now only applies to certain 'high risk' sites where the extent of the EPR zone may be uncertain (see Appendix H)
5.1.4.3	—	Premises served by HV AC mains supply	This requirement considered too onerous and deleted — covered by Clause 6.1.1
5.1.4.4	6.1.3	Engineered installation	No change but a note has been added to the effect that the reference document will change soon
5.1.4.5	6.1.4	Carrier notification	Notification now to be in writing
5.1.5	6.2	Low frequency induction (LFI)	
5.1.5.1	6.2.1	General	Editorial changes only
Note	Appendix H	Guidance	The note now refers to Appendix H
5.1.5.2	6.2.2	Engineered installation	No change
5.1.5.3	6.2.3	Carrier notification	Notification now to be in writing

Old Clause S009:2001	New Clause S009:2006	Subject	Comments
5.1.6	5.12	Alterations and additions	No change
5.1.7	11.1	Optical fibre systems	
5.1.7.1	11.1.2	System compliance	No change
5.1.7.2	11.1.3	Safety of the installation	Item (e) expanded to include disposal of waste material
5.1.8	11.2	Coaxial cable systems	Editorial changes, notes added
—	7	HAZARDOUS AREAS AND DAMP LOCATIONS	New heading
5.1.9	7.1	Hazardous areas (explosive atmosphere)	Editorial changes only
5.4.7	7.2	Damp locations	The word 'situations' replaced by 'locations'
5.4.7.1	7.2.1	General	The word 'and' replaced by 'or'
—	7.2.2	Restricted zones	New heading
—	7.2.2.1	Application	New explanatory information
5.4.7.2.1	7.2.2.2	Restricted zone boundaries	This clause defines the zones
5.4.7.3	7.2.3	Equipment installed in a restricted zone	Editorial changes only, Note 1 added
5.1.10	—	Catenary support systems	General cable support requirements apply (see below)
—	8	CABLE SUPPORTS AND ENCLOSURES	New heading
5.1.10.1	8.1	General	Made more generic
—	8.2	Improper support of cabling	New heading
5.1.1.2 Note	8.2.1	Attachment to other services	Securing cable to other service cables, conduits or pipes now explicitly prohibited
—	8.2.2	Suspended ceilings	Laying cables on ceiling tiles or tying them to hanger rods now explicitly prohibited
5.1.14	8.3	Conduit	
5.1.14.1	8.3.1	Prohibited conduit colours	Reference to AS 1345 deleted, 'single mode' deleted before 'optical fibre' in (c) (i.e. any type of optical fibre cable must be labelled), Note 5 added
Table 1	Table 1	Prohibited conduit colours for customer cabling	Title and column heading changes only
5.1.14.2	8.3.2	Access to conduit of a prohibited colour	No change
—	8.3.3	Sharing of conduit with a hazardous service	New heading

Old Clause S009:2001	New Clause S009:2006	Subject	Comments
5.1.14.3	8.3.3.1	Sub-ducting of customer cabling in conduit of another service	Editorial changes only
—	8.3.3.2	Sub-ducting of LV telecommunications circuits with other customer cables	New
5.1.10.2	8.4, 20.19	Earthing of cable support systems and cable enclosures	The clause now refers to common requirements for earthing of parts
5.1.10.3	8.5	Separation from other services	Editorial changes only
5.4.5.2	8.6	Removal of sharp edges	No change
—	8.7	Fire detection and fire alarm system cables	New recommendation re installing cabling above fire system cables
—	9	SEPARATION OF SERVICES — GENERAL	New heading
—	9.1	Separation from LV power or HV circuits	New heading
—	9.1.1	Separation from LV or HV cables	This clause is simply a referral to the appropriate section
5.1.11	9.1.2, 9.1.3	Separation from LV or HV power terminations	See individual clause changes below
5.1.11.1	5.9.1	Access to cable terminations	Expanded to cover all voltage/service classifications, notes added
5.1.11.2	9.1.2	Separation from LV power terminations	The word 'power' added after 'LV'
—	9.1.2.1	Shared enclosure	Included to remove doubt
5.1.11.2.1	9.1.2.2	Prevention from accidental personal contact with LV power terminations	Allowance made for building control services in a restricted access location
5.1.11.2.2	9.1.2.3	Prevention from accidental electrical contact between customer cable terminations and LV power terminations	Allowance made for building control services in a restricted access location
5.1.11.2.3	9.1.2.3, 20.17	Earthing of metallic barriers	Clause 9.1.2.3 of S009:2006 now refers to common requirements for earthing of metallic barriers
5.1.11.3	9.1.3	Separation from HV circuit terminations	HV is now classified as either an HV circuit or HV power (refer to the S009:2006 definitions)
5.1.11.3.1	9.1.3.1	Shared enclosure	Notes added
5.1.11.3.2	9.1.3.2	Separation of enclosures	No change but note added
—	9.2	Separation from services other than LV or HV power	New heading

Old Clause S009:2001	New Clause S009:2006	Subject	Comments
—	9.2.1	General	New requirement for separation from other services to allow access or repair
5.1.12	9.2.2	Separation from non-electrical hazardous services	No change but note added
—	9.3	Separation of ELV, SELV, TNV, limited current and LV telecommunications circuits	New requirements for separation of different types of telecommunications services
—	9.3.1	Sharing of cable	New requirement in relation to LV telecommunications circuits
—	9.3.2	ELV circuit terminations	New requirement for separation of ELV at cable terminations
—	9.3.3	LV telecommunications circuits	New requirement for separation of LV telecommunications circuit cables
5.1.13	9.4	Separation from lightning down-conductors	Telecommunications earthing and power distribution conductors added
5.1.14	8.3	Conduit	
5.1.14.1	8.3.1	Prohibited conduit colours	Reference to AS 1345 deleted, 'single mode' deleted before 'optical fibre' in (c) (i.e. any type of optical fibre cable must be labelled), Note 5 added
Table 1	Table 1	Prohibited conduit colours for customer cabling	Title and column heading changes only
5.1.14.2	8.3.2	Access to conduit of a prohibited colour	No change
5.1.14.3	8.3.3.1	Sub-ducting of customer cabling in conduit of another service	Editorial changes only
5.1.15	9.5	Steel wire armoured (SWA) cables	Editorial changes only
5.1.16 5.1.16.1 5.1.16.2	20.4	Telecommunications power distribution current limiting	Consolidated into one clause, editorial changes, note added
5.1.16.3	20.8.2	Earthing conductors, multi-pair cable	Editorial changes only
5.1.16.4	20.8.2 Note	Cable shield or drain wire earthing	As this was simply a cross-reference, it was made a note
—	10	SURGE SUPPRESSION	New heading
5.1.17	10.1	Assessment of the need for surge suppression	See individual clause changes below
5.1.17.1	10.1	Where the network boundary is not at the building, etc.	Now only applies to twisted pair cable, notes added

Old Clause S009:2001	New Clause S009:2006	Subject	Comments
5.1.17.2 5.1.17.2 (a) 5.1.17.2 (b)	10.2 —	Installation of surge suppression where required Subsequent appearances	Editorial changes, notes added Deleted (Clause 10.2 of S009:2006 automatically applies for all buildings)
5.1.17.3	10.3	Surge suppression device	Editorial changes only
5.1.17.4	10.4	Earthing of surge suppression device	Editorial changes only
—	11	OPTICAL FIBRE AND COAXIAL CABLE SYSTEMS	New heading
5.1.7	11.1	Optical fibre systems	
—	11.1.1	General exemption from separation requirements	New clause about considering the safety of the cabling provider
5.1.7.1	11.1.2	System compliance	No change
5.1.7.2	11.1.3	Safety of the installation	Item (e) expanded to include disposal of waste material
5.1.8	11.2	Coaxial cable systems	Editorial changes, notes added
5.2	12	DISTRIBUTORS	
5.2.1	12.1	General	Editorial changes only
—	12.2	Cross-connections	New recommendation about matching the cross-connection to the class of the cabling
5.2.2	12.3	Records	
—	12.3.1	General	New heading
5.2.2.1	12.3.1 (a)	Jumper records	Editorial changes only
5.2.2.2	12.3.1 (b)	To be 'legible and updateable'	Now clearly only applies to jumpers (not patch cords)
5.2.2.3	12.3.2	Cabling outside the boundaries of the premises	Clarified that this only applies to cabling connected to that distributor
5.2.2.4	12.3.3	Identification of power feeding circuits	Made less ambiguous, note added
5.2.3	12.4	Outdoor installation	
5.2.3.1	12.4 (a)	IP rating	Editorial changes only
5.2.3.2	12.4 (b)	Maintaining IP rating	Editorial changes only
5.2.4	12.5	Enclosure construction	Editorial changes only
5.3	—	Network boundary	Deleted (separately addressed in new headings 13, 14 and 15)
5.3.1	—	General	Redundant heading
5.3.1.1	5.13	Tampering or interference with a carrier facility	Note added to accommodate the principle of Telstra's 'A2A'

Old Clause S009:2001	New Clause S009:2006	Subject	Comments
5.3.1.2	5.14	Defective customer cabling or customer equipment not to be reconnected	Reference to disconnection at the network boundary deleted (the cabling or equipment may be disconnected anywhere)
5.3.1.3	—	Where the network boundary is not at the customer's building	Redundant — this requirement automatically applies anyway
5.3.2	13	MAIN DISTRIBUTION FRAME (MDF)	Formerly headed 'Distributors', aka 'network boundary distributor'
—	13.1	Application	New guidance on MDF usage
—	13.2	General	New heading
5.3.2.1	13.2 (a)	To meet distributor requirements	Editorial changes only
5.3.2.8 (b)	13.2 (b)	MDF to be structurally robust	No change
—	13.3	Location	New heading
—	13.3 (a)	MDF should be located near electrical switchboard	New recommendation to align with notes to Figures 1 to 5
5.3.2.3	13.3 (b)	To be free from dust and moisture	Editorial changes only
5.3.2.2	13.3 (c) 13.3 Note	MDF to be securely attached to a permanent building element, etc. and carrier consulted	Editorial changes only
5.3.2.3	13.3 (b)	To be free from dust and moisture	Editorial changes only
5.3.2.5	13.4	Prohibited locations	Editorial changes only
5.3.2.4	13.5	Security	Editorial changes, Note 2 added
5.3.2.5	13.4	Prohibited locations	Editorial changes only
5.3.2.6 5.3.2.6.1	13.6	Access clearances	Editorial changes only
—	13.7	Height	New heading
5.3.2.8 (e)	13.7.1	Highest terminal or socket	Explanatory note added
—	13.7.2	Lowest terminal or socket	New heading
5.3.2.8 (f)	13.7.2.1	Outdoor MDF	Explanatory note added
5.3.2.8 (g)	13.7.2.2	Indoor MDF	Explanatory note added
5.3.2.6.2	13.8	Exit from the MDF room	Amended to prohibit MDF installation in such a room. Note 1 now only recommends that a cabling provider not work in a non-conforming room
5.3.2.6.3	—	Height where end-user has access	Deleted (many racks don't comply)
5.3.2.8 (a)	13.9	Illumination	Note added (500 lux at a height of 1 m recommended)

Old Clause S009:2001	New Clause S009:2006	Subject	Comments
5.3.2.8 (d)	13.10	Inbuilt MDF compartment	
(i)	—	General compliance	Redundant — 12.5 and 13.5 of S009:2006 automatically apply
(ii)	13.10	Carrier side front clearance	Notes added
5.3.2.8 (c)	13.11	Carriers' terminations	Notes added
5.3.2.8 (h)	13.12	Marking	New heading
(i)	13.12 (a)	Verticals	No change
(ii)	13.12 (b)	Terminations	No change
5.3.2.7	13.13	Cross-connections	
5.3.2.7.1	13.13.1	Connection on the carrier side of the MDF	The words 'by a carrier' inserted, notes added
5.3.2.7.2	13.13.3	Removal of 'dead' jumpers	The words 'by a carrier' inserted, note added
5.3.2.7.3	13.13.2	Connection on customer side of the MDF	Note added
5.3.2.7.2	13.13.3	Removal of 'dead' jumpers	The words 'by a carrier' inserted, note added
5.3.2.7.4	13.13.4	Miscellaneous	No change
5.3.2.8	—	Additional requirements	Requirements now listed under appropriate headings (see below)
5.3.2.8 (a)	13.9	Illumination	Note added (500 lux at a height of 1 m recommended)
5.3.2.8 (b)	13.2 (b)	MDF to be structurally robust	No change
5.3.2.8 (c)	13.11	Carriers' terminations	Notes added
5.3.2.8 (d)	13.10	Inbuilt MDF compartment	
(i)	—	General compliance	Redundant — 12.5 and 13.5 of S009:2006 automatically apply
(ii)	13.10	Carrier side front clearance	Notes added
5.3.2.8 (e)	13.7.1	Highest terminal or socket	Explanatory note added
5.3.2.8 (f)	13.7.2.1	Outdoor MDF	Explanatory note added
5.3.2.8 (g)	13.7.2.2	Indoor MDF	Explanatory note added
5.3.2.8 (h)	13.12	Marking	New heading
(i)	13.12 (a)	Verticals	No change
(ii)	13.12 (b)	Terminations	No change
5.3.3	14	NETWORK TERMINATION DEVICE	
—	14.1	Application	New guidance on NTD usage
5.3.3.1	14.2	Connection on customer side of the NTD	The words 'by the carrier' inserted, note added
5.3.3.2	14.3	Connection on carrier side of NTD	Note added
5.3.3.3	14.4	Testing	Editorial changes only

Old Clause S009:2001	New Clause S009:2006	Subject	Comments
5.3.4	—	NTD Enclosures	Deleted
—	15	TELECOMMUNICATIONS OUTLETS	New heading
—	15.1	Outlet types	New explanation of TO types
—	15.2	Protection against contact with live parts of sockets	New recommendation for premises frequented by small children
—	15.3	Damp locations	New heading
5.4.7.2.1	15.3.1	Restricted zones	Editorial changes only
5.4.7.2.2	15.3.2	Outside restricted zones	Editorial changes only
—	15.4	First telecommunications outlet ('first socket')	New heading
—	15.4.1	Application	New guidance for identifying the 'first TO'
5.3.5 5.3.5.1	15.4.2	Connection of customer cabling	New heading — see individual paragraph references below
5.3.5.1 (a)	15.4.2.1	Twisted pair cabling	Editorial changes, note added
—	15.4.2.2	Coaxial or optical fibre cabling	Previously implied by default, now specifically addressed
5.3.5.1 (b)	—	Connection to changeover switch	Deleted (15.4.2.4 and 5.13 of S009:2006 apply)
5.3.5.1 (c)	15.4.2.3	Obsolete hard-wired telephone	Editorial changes only
5.3.5.1 (d)	15.4.2.1 (b)	Connection on customer side of first TO	Editorial changes only
5.3.5.2	15.4.2.4, 5.13	Intermediate devices	Amended to support carrier authorisation like Telstra's 'A2A'
5.4	16	INDOOR CABLING	
5.4.1	—	General (fire stopping, flammability)	Clauses now have separate headings
5.4.1.2	16.1	Cable flammability	Amended for clarity, notes added
5.4.1.1	16.2	Fire stopping	Editorial changes only
5.4.1.2	16.1	Cable flammability	Amended for clarity, notes added
5.4.2	16.3	Separation from LV power cables	
5.4.2.1, 5.4.2.1.1	16.3.1	General	Editorial changes only
5.4.2.1.2	16.3.2	Cabling in building framework	Editorial changes only
5.4.2.2	16.3.3	Cables in common trunking or a common duct or enclosure	Amended to include common enclosures, example added
5.4.2.3	16.3.4	Undercarpet cabling	
5.4.2.3.1	16.3.4 (a)	Parallel separation	Editorial changes only

Old Clause S009:2001	New Clause S009:2006	Subject	Comments
5.4.2.3.2	16.3.4 (b)	Separation at crossings	Editorial changes only
5.4.3	16.4	Separation from HV circuits	
5.4.3.1	16.4.1	Single-core cables	Editorial changes only
5.4.3.2	16.4.2	Multi-core cables	Editorial changes only
5.4.4	16.5	Prohibited use of flame-propagating conduit	Editorial changes only, note added
5.4.5	8	CABLE SUPPORTS AND ENCLOSURES	
5.4.5.1	8.1 (b)	General	Consolidated with other requirements
5.4.5.2	8.6	Removal of sharp edges	No change
5.4.6	16.6	Cabling in lift and hoist shafts	
5.4.6.1	16.6.1	Permanently fixed cables	Editorial changes only
5.4.6.2	16.6.2	Travelling cables	Editorial changes, reference to AS/NZS 3000 & AS 1979 deleted
5.4.7	7.2	Damp locations	The word 'situations' replaced by 'locations'
5.4.7.1	7.2.1	General	The word 'and' replaced by 'or'
5.4.7.2	—	TOs and MDFs	Now covered separately in MDF and TO sections
5.4.7.2.1	7.2.2.2 13.4 (f) 15.3.1	Restricted zone boundaries Prohibited location for MDF Prohibited location for TO	This clause defines the zones This clause prohibits MDFs in the restricted zones This clause prohibits TOs in the restricted zones
5.4.7.2.2	13.3 (b) 15.3.2	MDF in a damp location outside restricted zones TO in a damp location outside restricted zones	Now addressed in the MDF section Now addressed in the TO section
5.4.7.3	7.2.3	Equipment installed in a restricted zone	Editorial changes only, Note 1 added
5.4.8	16.7	Cabling over or under floor covering	
5.4.8.1	16.7.1	Physical protection	No change
5.4.8.2	16.7.2	Separation from power cabling	Editorial changes only
5.5	17	OUTDOOR CABLING — GENERAL	
5.5.1	—	General	Clauses now have separate headings
5.5.1.1	17.1	Protection rating	Requirement added to maintain IPX3 rating at all times

Old Clause S009:2001	New Clause S009:2006	Subject	Comments
5.5.1.5	17.2	Cabling between premises	Noted reference to HB 243 deleted, other notes added
5.5.1.2	—	Submerged (underwater) cabling	Deleted (normal underground cabling requirements apply)
5.5.1.3	17.3	Cabling in a sheltered structure	Aboveground trunking system & other sheltered structure added
5.5.1.4	18.3	Conduit and marking tape	
5.5.1.4.1	18.3.3	Conduit compliance	Now only applies to underground cabling, plus exceptions are factored in
5.5.1.4.2	18.3.4	Sub-ducting of customer cable in enveloper conduit or pipe	Now only applies to underground cabling
5.5.1.5	17.2	Cabling between premises	Noted reference to HB 243 deleted, other notes added
5.5.2	—	Outdoor surface cabling	Clauses now have separate headings
5.5.2.1	17.4	Exposure to UV radiation (sunlight)	Editorial changes, notes added
5.5.2.2	17.5	Outdoor surface cabling	Editorial changes only
5.5.3	18	UNDERGROUND CABLING	
5.5.3.1	18.1	Pits and access holes	
5.5.3.1.1	18.1.1	Identification and marking	Notes added
5.5.3.1.2	18.1.2	Driveways	No change
—	18.1.3	Heavy loads	New requirement
5.5.3.1.3	18.1.4	Building entry conduit	No change
5.5.3.1.4	18.1.5	Sharing with LV or HV power	Editorial changes, Note 2 added
5.5.3.1.5	18.1.6	HV sites	No change
5.5.3.2	18.2	Pillars and cabinets	
5.5.3.2.2	18.2.1	Locking in public areas	Note added
5.5.3.2.1	18.2.2	HV sites	No change
5.5.3.2.2	18.2.1	Locking in public areas	Note added
5.5.3.3	18.3	Conduit and marking tape	
5.5.3.3.1	18.3.1	Public footways and roadways	Editorial changes only
5.5.3.3.1 (a)	18.3.1 (a)	Compliant conduit	No change
5.5.3.3.1 (b)	18.3.1 (b)(i) 18.3.1 (b)(ii)	White marking tape	Editorial changes only
5.5.3.3.2	18.3.1 (b)(iii)	Marking tape positioning	No change
—	18.3.2	Other locations	New recommendations
5.5.1.4.1	18.3.3	Conduit compliance	Exceptions included, notes added

Old Clause S009:2001	New Clause S009:2006	Subject	Comments
5.5.1.4.2	18.3.4	Sub-ducting of customer cable in enveloper conduit or pipe	Ambiguities addressed, note added
5.5.3.4 5.5.3.4.1	18.4	Cable compliance	UV resistance requirement added, coaxial cable, blown fibre and special applications cable excluded, notes added
5.5.3.4.2	—	After 1 January 2004	Redundant
5.5.3.4.3	18.5	Blown fibre tube systems	No change
5.5.3.5	18.6	Depth of cover	
5.5.3.5.1	18.6.1	Public footways or roadways	Editorial changes, note added
5.5.3.5.2	18.6.2	Places other than public footways or roadways	Order of options changed, otherwise no changes
5.5.3.6	18.7	Crossing another service	
5.5.3.6.1	18.7.1	General	Possible inconsistency with LV and HV power separation requirements fixed
—	18.7.2	Crossing with LV or HV power	New heading
5.5.3.6.2	18.7.2 (a)	Crossing above power	No change
5.5.3.6.3	18.7.2 (b)	Crossing below power	Editorial changes only
5.5.3.6.4	18.7.2 (c)	Separation from power	Editorial changes only
—	18.8	Separate trench ('exclusive trench')	New heading
—	18.8.1	General	New requirement for separation from other services
5.5.3.7	18.8.2	Parallel run with LV or HV power	Editorial changes only
5.5.3.8	18.9	Shared trench with another service	
5.5.3.8.1	18.9.1	General	Possible inconsistency with LV and HV power separation requirements fixed, note added
5.5.3.8.2	18.9.2	Shared trench with LV or HV power	Conduit requirements made more explicit
5.5.3.9	18.10	Low frequency induction (LFI)	No change
—	18.11	Exclusion zones	New requirement for working near underground utility services
Table 2	Table 2	Underground customer cabling separation from power cabling	Conduit requirements made more explicit for nil separation plus editorial changes
5.5.4	19	AERIAL CABLING	
5.5.4.1	—	Ground clearance	See Clause 19.2 of S009:2006
—	19.1	Poles and support structures	New heading

Old Clause S009:2001	New Clause S009:2006	Subject	Comments
—	19.1.1	General	New heading
5.5.4.1.1	19.1.1 (a)	To be fit for the purpose	Editorial changes only
—	19.1.1 (b)	Depth	New requirement
—	19.1.1 (c)	Regular inspections	New recommendation
—	19.1.2	Separation of poles and structures from aerial power lines	New heading
—	19.1.2.1	Parallel pole routes	Requirements of SAA HB 87 and SAA HB 103 included instead of cross-references to them
—	19.1.2.2	Crossings	Requirements of SAA HB 103 included instead of a cross-reference to it
5.5.4.1.2	19.2	Ground clearance	No change
5.5.4.2	19.3	Cable compliance	
5.5.4.2.1	19.3.1	UV resistance	Editorial changes only
—	19.3.2	Integral bearer cable	Integral bearer cable added
5.5.4.2.2	8.1	Catenary supports	Clause 8.1 of S009:2006 automatically applies
5.5.4.3	19.4	Fastening of catenary supports or bearers	
5.5.4.4	19.4 (a)	Strength	No change
5.5.4.3.1	19.4 (b)	Extreme weather conditions	No change
5.5.4.3.2	19.4 (c)	Termination	No change
5.5.4.4	19.4 (a)	Strength	No change
5.5.4.5	19.5	Crossings and shared poles (joint use) with aerial power lines	
—	19.5.1	General	New introductory clause
5.5.4.6 (a)	19.5.2	Permission of the owner of the poles	Editorial changes only
5.5.4.5.1	19.5.3	Attachment to poles or structures carrying power lines exceeding 66 kV	Prohibition now only applies to pole attachment & exception for optical fibre cable removed
5.5.4.5.2 (a)	19.5.4	Attachment to poles or structures carrying HV power lines not exceeding 66 kV	Editorial changes, engineered solution option removed
5.5.4.5.2 (e)	19.5.5	Attachment to a pole or structure carrying an HV power transformer	Now prohibited outright for customer cabling
—	19.5.6	Crossing aerial HV power lines exceeding 330 kV	In-span crossings now allowed for power lines up to 330 kV
—	19.5.7	Relative position of aerial customer cabling and aerial power lines	New heading

Old Clause S009:2001	New Clause S009:2006	Subject	Comments
—	19.5.7.1	Crossings	New heading
5.5.4.5.2 (f)	19.5.7.1 (a)	Crossing above or below power line	Clearance above power line if cable breaks changed from 3 m to 5 m for compatibility with Table 3
5.5.4.5.2 (g)	19.5.7.1 (b), Table 3	Separation from an LV power line and any other services	No change for crossings under insulated LV power lines in span but other cases now addressed based on SAA HB 103
5.5.4.5.2 (h)	19.5.7.1 (b), Table 3	Separation from an HV power line	Separation for crossings under HV power lines amended based on SAA HB 103
—	19.5.7.1 (c)	Point of crossing	New requirement based on SAA HB 103
—	19.5.7.1 (d)	Position of poles at crossings	New requirement based on SAA HB 103
5.5.4.6 (f)	19.5.7.2	Shared poles or structures ('joint use')	Editorial changes only
5.5.4.5.2 (j) 5.5.4.6 (g) 5.5.4.6 (h) 5.5.4.6 (j)	19.5.7.3, Table 3	Separation from aerial power lines and fittings	Changes made based on SAA HB 103 requirements
—	19.5.8	Cable	New heading
5.5.4.5.2 (b)	19.5.8.1	Cable type	Editorial changes only
5.5.4.5.2 (c)	19.5.8.2 (a)	Cable bearer insulation	Editorial changes only
—	19.5.8.2 (b)	Cable bearer shrouding	New — required by SAA HB 87
5.5.4.5.2 (d)	19.5.8.2 (c)	Cable bearer earthing	Editorial changes only
5.5.4.5.2 (e)	19.5.5	Attachment to a pole or structure carrying an HV power transformer	Now prohibited outright for customer cabling
5.5.4.5.2 (f)	19.5.7.1 (a)	Crossing above or below power line	Clearance above power line if cable breaks changed from 3 m to 5 m for compatibility with Table 3
5.5.4.5.2 (g)	19.5.7.1 (b), Table 3	Separation from an LV power line and any other services	No change for crossings under insulated LV power lines in span but other cases now addressed based on SAA HB 103
5.5.4.5.2 (h)	19.5.7.1 (b), Table 3	Separation from an HV power line	Separation for crossings under HV power lines amended based on SAA HB 103
5.5.4.5.2 (j)	19.5.7.3, Table 3	Separation from aerial power lines and fittings	Changes made based on SAA HB 103 requirements
5.5.4.6	19.5	Crossings and shared poles (joint use) with power lines	
5.5.4.6 (a)	19.5.2	Permission of the owner of the poles	Editorial changes only

Old Clause S009:2001	New Clause S009:2006	Subject	Comments
5.5.4.6 (b)	19.5.4	Attachment to poles or structures carrying HV power lines not exceeding 66 kV	Shared poles permitted as long as LV power lines exist below the HV lines
5.5.4.6 (c)	19.5.8.1	Cable type	Editorial changes only
5.5.4.6 (d)	19.5.8.2 (a)	Cable bearer insulation	Editorial changes only
5.5.4.6 (e)	19.5.8.2 (c)	Cable bearer earthing	Editorial changes only
5.5.4.6 (f)	19.5.7.2	Shared poles or structures ('joint use')	Editorial changes only
5.5.4.6 (g)	19.5.7.3, Table 3	Separation from aerial power lines and fittings	Changes made based on SAA HB 87 requirements
5.5.4.6 (h)	19.5.7.3, Table 3	Separation from power fittings	Editorial changes only
5.5.4.6 (j)	19.5.7.3, Table 3	Aerial joint/termination enclosure separation from power lines and fittings	Editorial changes only
5.5.4.6 (l)	19.5.9	Joints or terminations	Editorial changes only
5.5.4.6 (k)	19.5.10	Power earthing conductors	Editorial changes only
5.5.4.6 (l)	19.5.9	Joints or terminations	Editorial changes only
—	19.6	Separation from other telecommunications cabling	New requirement
5.5.4.7	19.7	Cabling across watercourses	Now only applies to navigable water
—	19.8	Exclusion zones	New requirement for working near aerial power lines
—	Table 3	Minimum separation of aerial customer cabling from aerial power lines and fittings	New table of separation requirements including new HV separations based on SAA HB 87 and SAA HB 103
5.6	20	TELECOMMUNICATIONS EARTHING AND POWER DISTRIBUTION	
—	20.1	Application	New application guidance
5.6.1	20.2	Earthing systems, general description	
5.6.1 (a)	20.2.1	Communications Earth System (CES)	Editorial changes only
5.6.1 (b)	20.2.2	Telecommunications Reference Conductor (TRC)	No change
5.6.1 (c)	20.2.3	ELV DC power supply system	Editorial changes only
—	20.2.4	DC earth return circuit	New general description
5.6.1 Note 1	20.12.1 Note	The CES is available for general communications earthing	Editorial changes only
5.6.1 Note 2	20.3	Compliance labelling	Telecommunications power distribution components added

Old Clause S009:2001	New Clause S009:2006	Subject	Comments
5.1.16.1 5.1.16.2	20.4	Power distribution current limiting	Editorial changes, note added
—	20.5	EPR hazard zones	New clause barring earthing or bonding within EPR hazard zone
5.6.2	—	General requirements for CES and TRC	Redundant heading
5.6.2.1	20.14	Interconnection of CES and TRC systems	Note amended
5.6.2.2	20.6	Functional earth requirement	Amended to accommodate historical changes in earthing requirements
—	20.7	Protective earth requirement	New clause to consolidate separate requirements with additional options
5.6.2.3	20.8	Earthing and bonding conductors	New heading
5.6.2.3.1	20.8.1	Conductor type	Editorial changes only
5.6.2.3.2	20.8.4	Connection or jointing/coupling of conductors	Editorial changes only
5.6.2.3.3	20.8.2	Multi-pair cable	Editorial changes only
5.6.2.4 5.6.2.4.1 5.6.2.4.2	20.8.3	Conductor size	Editorial changes only
5.6.2.3.2	20.8.4	Connection or jointing/coupling of conductors	Editorial changes only
5.6.2.5	20.9	Earthing or bonding bars and terminals	New heading
—	20.9.1	Capacity	New heading
5.6.2.5 (a) 5.6.2.5 (b)	20.9.1 (a) 20.9.1 (b)	Capable of terminating 6 mm ² Sized to suit the installation	Editorial changes only
5.6.2.6	20.9.2	Earthing or bonding conductor connection	
—	20.9.2 (a)	Screw terminals to be used	New, specific requirement (was implied by default in S009:2001)
5.6.2.6 (a)	20.9.2 (b)	Insulation removal	No change
5.6.2.6 (b)	20.9.2 (c)	Conductor consolidation	No change
5.6.2.6 (c)	20.9.2 (d)	Solder not to be used	No change
5.6.2.6 (d)	20.9.2 (e)	Use of cable lugs	Editorial changes only
5.6.2.6 (e)	20.9.2 (f)	Spade terminals not to be used	Editorial changes only
—	20.9.3	Access to earthing/bonding bars or terminals	New requirement
5.6.2.7	20.10	Earthing and bonding conductor joints and couplings	
5.6.2.7.1	20.10.2	Insulation of the joint/coupling	Editorial changes only

Old Clause S009:2001	New Clause S009:2006	Subject	Comments
—	20.10.1	Jointing/Coupling method	New heading
5.6.2.7.2	20.10.1.1	General	Editorial changes only
5.6.2.7.2 (a)	20.10.1.2	Soldered connections	Editorial changes only
5.6.2.7.2 (b)	20.10.1.3	Clamped connections	Editorial changes only
5.6.2.7.2 (c)	20.10.1.4	Tunnel type connections	Editorial changes only
5.6.2.7.2 (d)	20.10.1.5	Crimped connections	Editorial changes only
—	20.10.1.6	Insulation displacement connectors	Added to remove doubt that IDCs must not be used for jointing or coupling (was implied by default in S009:2001)
5.6.2.7.1	20.10.2	Insulation of the joint/coupling	Editorial changes only
5.6.2.8	20.11 20.11.1	Equipotential bonding General	Editorial changes, notes added
5.6.2.8 (a)	20.11.2	Communications bonding conductor	Editorial changes only Note added re surge suppression 'Telecommunications Bonding Conductor' added as option
(i)	20.11.2.1	Colour and size	
(ii)	20.11.2.2	Length	
(iii)	20.11.2.3	Labelling	
—	20.11.2.4	Resistance	Resistance limit added for consistency with AS/NZS 3000
Table 3	Table 4	Resistance vs. length for standard copper earthing conductors	Table renumbered and editorial change to title only
5.6.2.8 (b)	20.11.3	Communications Earth Terminal	Editorial changes only New heading Editorial changes only Editorial changes only No change
(i)	20.11.3.1	General	
—	20.11.3.2	Location	
(ii)	20.11.3.2 (a)	To be readily accessible	
(iii)	20.11.3.2 (b)	Not on or within a switchboard	
(iv)	20.11.3.3	Marking	
5.6.2.8 (c)	20.11.4	Connection to electrical earthing system	20.11.4 (a) states the legal requirements while Figures 1-4 show approved methods. The local energy authority decides who can do the bonding Editorial changes only New requirement No change
(i)	20.11.4 (a), 20.11.4 Note 1	Connection methods	
(ii)	20.11.4 (a)(i), 20.11.4 Note 2	Compliance with AS/NZS 3000	
—	20.11.4 (a)(ii)	Protection against corrosion	
(iii)	20.11.4 (b)	Integrity of the electrical earthing system	

Old Clause S009:2001	New Clause S009:2006	Subject	Comments
5.6.3	20.12	Communications Earth System	
5.6.3.1	—	Connection to earth reference	Redundant — 20.12.3 applies
—	20.12.1	Description of the CES	New information included
5.6.1 Note 1	20.12.1 Note	The CES is available for general communications earthing	Editorial changes only
5.6.3.2	20.12.2	CES conductors	
5.6.3.2.1	20.12.2.1	Colour	Editorial changes only
—	20.12.2.2	Size	New heading
5.6.3.2.2	20.12.2.2 (a)	Resistance limits	Editorial changes only
5.6.3.2.3	20.12.2.2 (b)	Minimum size	Editorial changes only
5.6.3.3	20.12.3	Equipotential bonding of the CES	
5.6.3.3.1	20.12.3 (a)	General bonding requirements	Editorial changes only
5.6.3.3.2	20.12.3 (b)	To be bonded at the relevant floor or section of the building	Editorial changes only
5.6.3.4	20.12.4	Resistance of the CES	Editorial changes, Note 1 added
5.6.4	20.13	Telecommunications Reference Conductor (TRC)	
—	20.13.1	Description of the TRC system	New information included
5.6.4.1	20.13.4	Connection to an earth reference	Reference to Figure 5 added
5.6.4.2	20.13.2	TRC system components	Editorial changes, including: <ul style="list-style-type: none"> • 'nominated distributor' now called 'designated distributor' • 'CSS' now called 'CAE' to align with AS/ACIF S003
5.6.4.3	20.13.3	TRC to be exclusive to telecommunications services	No change
5.6.4.1	20.13.4	Connection to an earth reference	Reference to Figure 5 added
5.6.4.4	20.13.5	TRC system conductors	
5.6.4.4 (a)	20.13.5.1	Colour	Editorial changes only
—	20.13.5.2	Size	New heading
5.6.4.4 (b)	20.13.5.2 (a)	Resistance limits	Editorial changes only
5.6.4.4 (c)	20.13.5.2 (b)	Minimum size	Editorial changes only
5.6.4.5.4	20.13.5.2 (c)	A conductor feeding any other conductor	Editorial changes only
5.6.4.5	20.13.6	Cabling method	
5.6.4.5.1	20.13.6 (b)	To emanate from the designated distributor	Editorial changes only
5.6.4.5.2	20.13.6 (a)	To be bonded at main/first switchboard	Editorial changes only

Old Clause S009:2001	New Clause S009:2006	Subject	Comments
5.6.4.5.1	20.13.6 (b)	To emanate from the designated distributor	Editorial changes only
5.6.4.5.3	20.13.6 (c)	To be cabled in tree or star topology	Editorial changes only
5.6.4.5.4	20.13.5.2 (c)	A conductor feeding any other conductor	Editorial changes only
5.6.4.6	20.13.7	TRC link bars	
5.6.4.6.1	20.13.7 (a)	General	Editorial changes only
5.6.4.6.2	20.13.7 (b)	TRC link bar insulation	Editorial changes only
5.6.4.7	20.13.8	Telecommunications Functional Earth Electrode (TFEE)	
5.6.4.7.1	20.13.8.1	Application	Editorial changes only
5.6.4.7.2	20.13.8.2	Type of electrode	
5.6.4.7.2 (a)	20.13.8.2 (a) 20.13.8.2 (b)	AS/NZS 3000 compliant types	Types listed instead of cross-reference to AS/NZS 3000
5.6.4.7.2 (b)	20.13.8.2 (c)	Galvanised star picket type	Depth requirements added
5.6.4.7.3	20.13.8.2 20.13.8.3	Depth of electrode Location of electrode	Requirements included instead of AS/NZS 3000 cross-reference
5.6.4.7.4	20.13.8.4	Labelling	No change
5.6.4.7.5	20.13.8.5	Conductor colour and size	Editorial changes only
—	20.13.8.6	Electrodes in separate buildings	New requirement for connection of TFEE where electrical earth electrode is in a separate building
5.6.4.8	20.13.9	Equipotential bonding of the TRC system	
—	20.13.9.1	General	New heading
5.6.4.8.1	20.13.9.1 (a)	Connection to electrical earth	Editorial changes only
5.6.4.8.2	20.13.9.1 (b)	To be bonded at one point only	Reference to Figure 5 added
5.6.4.8.3	20.13.9.2	TRC noise problems or excessive direct current	More information has been provided
5.6.4.9	20.13.10	TRC in a separate building	
5.6.4.9.1	20.13.10.1	Where there is electrical earthing system in the separate building	Editorial changes only
5.6.4.9.2	20.13.10.2	Where there is no electrical earthing system in the separate building	Editorial changes only
5.6.4.10	20.13.11	Resistance of the TRC system	Editorial changes only
5.6.2.1	20.14	Interconnection of CES and TRC	Note amended
5.6.5	20.15	ELV DC power supply system	Editorial changes only
5.6.6	20.16	DC earth return circuit	

Old Clause S009:2001	New Clause S009:2006	Subject	Comments
—	20.16.1	Separation from other earthing systems	New heading
5.6.6.1	20.16.1 (a)	To be separate from CES and TRC or any other earthing systems	Editorial changes only
5.6.6.2	20.16.1 (b) 20.16.2 20.16.3 Note	Separate conductor to be used Earth electrode Cable pair extension	Editorial changes only Requirements made more specific Editorial changes only
5.6.6.3	20.16.3	Conductor colour, size and labelling	Minimum conductor size added
—	20.17 20.17.1 20.17.2 20.17.3	Earthing of metallic barriers Prohibition — connection to TRC Earthing connection Earthing conductor colour and size	Individual requirements throughout S009 for earthing of metallic barriers have been consolidated into a common clause
5.6.7	20.18	Earthing of cable shields and drain wires	
5.6.7.1	20.18.1	General	Editorial changes only
5.6.7.2	20.18.2	Prohibition — connection to TRC	Editorial changes only
5.6.7.3	20.18.3	Allowable earthing points	Editorial changes only
5.6.7.4	20.18.4	Cabling between separate buildings or structures	Reference to separate electrical installations deleted, differential earth clamp option added, note added
5.6.8	20.19	Earthing of metallic supports, enclosures, frames, backmounts and steel wire armouring	
5.6.8.2 Note	20.19.1	General	Editorial changes only
5.6.8.1	20.19.2	Prohibition — connection to TRC	Editorial changes only
5.6.8.2	20.19.3 20.19.4	Earthing connection Earthing conductor colour and size	Editorial changes only Editorial changes only
Note	20.19.1	General	Editorial changes only
5.6.9	20.20	Earthing of surge suppression devices	
5.6.9.1	20.20.1	Surge suppression for the protection of end-users	Editorial changes, old Note 3 deleted (unnecessary and possibly misleading)
5.6.9.2	20.20.2	Surge suppression for the protection of customer equipment	New heading
5.6.9.2 (a)	—	Earthing connection (a) via the equipment power cord	Deleted (intrinsic to equipment design and possibly in conflict with AS/ACIF S003)

Old Clause S009:2001	New Clause S009:2006	Subject	Comments
5.6.9.2 (b)	20.20.2	Earthing connection via fixed wiring	Requirements made more explicit, notes added
Table 3	Table 4	Resistance vs. length for standard copper earthing conductors	Table renumbered and editorial change to title only
Table 4	Table 5	Minimum conductor sizes for earthing or bonding	Table renumbered and updated in accordance with clause changes
Figure 1	Figure 1	Typical CES for commercial premises with distributed cabling	Editorial changes to support clause changes, Note 2 illustrated on the drawing
Figure 2	Figure 2	Earthing options for a small distributor installation (e.g. domestic or small business premises)	Editorial changes to support clause changes, Note 2 illustrated on the drawing
Figure 3	Figure 3	Typical TRC system for commercial premises with distributed cabling	Editorial changes to support clause changes, Note 7 added
Figure 4	Figure 4	Equipotential bonding of TRC to the electrical earthing system via a differential earth clamp (where excessive noise or direct current)	Editorial changes to support clause changes, Note 5 added
—	Figure 5	Installation of a TFE where the electrical earth electrode is located at another building or structure	New
—	Figure 6	Connection of a metallic cable shield (or moisture barrier) of an underground or aerial customer cable at a building or structure	New
—	Appendix A	Restricted zones in damp locations	New normative appendix
—	Appendix B	Common cable colour codes	New informative appendix
—	Appendix C	Telecommunications outlets	New informative appendix
Appendix A	Appendix D	Recommended access clearances for MDFs and NTDs	Editorial changes plus Figure D.1 amended (zone 2 m to 1 m)
Appendix B	Appendix E	Direct current in the communications bonding conductor	Editorial changes only
Appendix C	Appendix F	Current-limited power feeding in telecommunications networks	Updated
—	Appendix G	LV telecommunications circuits	New informative appendix
—	Appendix H	Interference from HV power systems	New informative appendix
—	Appendix I	The IP Code	New informative appendix
—	Appendix J	The network boundary	New informative appendix
—	Appendix K	Cabling Provider Rules	New informative appendix

The policy objective of the greatest practicable use of industry self-regulation without imposing undue financial and administrative burdens on industry is central to the regulatory scheme of the *Telecommunications Act 1997*.

ACIF was established to implement the policy of industry self-regulation. It is a company limited by guarantee and is a not-for-profit membership-based organisation. Its membership comprises carriers/carriage service providers, business and residential consumer groups, industry associations and individual companies.

ACIF's mission is to develop collaborative industry outcomes that foster the effective and safe operation of competitive networks, the provision of innovative services and the protection of consumer interests. In the development of Industry Codes and Technical Standards as part of its mission, ACIF's processes are based upon its principles of openness, transparency, consensus, representation and consultation. Procedures have been designed to ensure that all sectors of Australian society are reasonably able to influence the development of Standards and Codes. Representative participation in the work of developing a Code or Standard is encouraged from relevant and interested parties. All draft Codes and Standards are also released for public comment prior to publication to ensure outputs reflect the needs and concerns of all stakeholders.



Published by:
**THE AUSTRALIAN
COMMUNICATIONS
INDUSTRY FORUM LTD**

Level 9
32 Walker Street
North Sydney
NSW 2060 Australia

Correspondence:
PO Box 444
Milsons Point
NSW 1565

T 61 2 9959 9111
F 61 2 9954 6136
TTY 61 2 9923 1911
E acif@acif.org.au
www.acif.org.au
ABN 56 078 026 507

Care should be taken to ensure that material used is from the current version of the Standard or Industry Code and that it is updated whenever the Standard or Code is amended or revised. The number and date of the Standard or Code should therefore be clearly identified. If in doubt please contact ACIF.